

Data Acquisition and Processing Report

NOAA Ship RAINIER

OPR-N372-RA-04

Approaches to Puget Sound, Washington

Hydrographic Letter Instructions dated March 23, 2004

Chief of Party: Commander John W. Humphrey, NOAA

A. EQUIPMENT

This Data Acquisition and Processing Report describes both the survey equipment used and the standard methods for acquisition applied to the equipment used. Not necessarily all equipment described within this report was used during data acquisition for all sheets of this project. Data were acquired by the following RAINIER survey launches:

<u>Hull Number</u>	<u>Vessel type</u>
1021	29 foot Jensen survey launch
1016	29 foot Jensen survey launch
1006	29 foot Jensen survey launch
1015	29 foot Jensen survey launch

Vessels 1021, 1016, 1006 and 1015 were used to acquire shallow-water multibeam (SWMB) data and sound velocity profiles. No unusual vessel configurations or problems were encountered on this project. Vessel descriptions and offset measurements are included in Appendix III of this report.

Two different categories of echosounder systems were utilized for project OPR-N372-RA-04. The individual system(s) chosen for use in a given area were decided at the discretion of the Hydrographer using the guidance stated in the Standing Project Instructions, the Hydrographic Letter Instructions, and the Field Procedures Manual, and depended upon the limitations of each system, the bottom topography, the water depth, and the ability of the platform vessel to safely navigate the area. These systems are described in the following section.

Sounding Equipment:

1. RESON 8101 Launch Shallow-Water Multibeam (SWMB)

Vessel 1021 is equipped with a Reson SeaBat 8101 mounted on a swing-arm which deploys the transducer from an "in transit" position recessed within the hull to a "survey" position extending beneath the hull once data collection commences. Vessel 1006 is equipped with a hull-mounted Reson SeaBat 8101. Both of these Reson SeaBat 8101s are equipped with option 033, Angle-Independent Imagery, and option 040, Extended Range Projector. The SeaBat 8101 is a 240 kHz multibeam system that measures relative water depths across a 150° swath, consisting of 101 individual 1.5° x 1.5° beams. This system was used to obtain full-bottom coverage in depths generally from 4 meters to 200 meters, with varying range scale values dependent upon the depth of water and across-track slope.

2. ELAC 1180 Launch Shallow-Water Multibeam (SWMB)

Vessels 1016 and 1015 are equipped with a hull-mounted Elac 1180, which is a single frequency (180 kHz), multibeam echosounder system for shallow and intermediate water depths. The transducer assembly consists of two flat-faced transducers, one starboard and one port, each mounted at a 38° angle from horizontal.

Echosounding is achieved using a Rotating Directional Transmission (RDT) method where sound is directed utilizing the directional gain of the complete transducer array. Sonar transmission occurs across adjacent sectors in a 3-step “subfan” process. Out of each of the 3 subfans within a sector, the receiving beamformer calculates 3 slightly overlapping beams each 1.5° wide with a spacing of 1.25° , for a total of 9 beams per sector. There are 7 fanwidth settings possible, the maximum of which (153.5°) utilizes 7 sectors, for a maximum total of 126 beams within a “virtual swath.” The Elac 1180 was generally used in depths of 50 to 100 meters with an acquisition swath width of 131° . Narrower fanwidth settings were selected at the discretion of the hydrographer in waters in between 100 and 300 meters of depth dependant upon both local conditions and the quality of the bottom trace. Surface sound velocity was measured using an Odom Digibar Pro, model db1200, velocimeter and digitally input into the Hydrostar computer during acquisition.

Side Scan Sonar

All the SWMB used by the RAINIER provide a low-resolution digital SSS record of the multibeam swath. This SSS imagery is primarily used during processing of the multibeam depth data to aid in determining whether anomalous soundings are true features or noise.

Positioning Equipment:

Vessels 1021, 1016, 1106, and 1015 are equipped with a TSS POS/MV Position and Orientation Sensor to measure and calculate position. The POS/MV is a GPS-aided inertial navigation system, which provides a blended position solution derived from both an Inertial Motion Unit (IMU) and an integrated GPS receiver. The IMU and GPS receiver are complementary sensors, and data from one are used to filter and constrain errors from the other, resulting in higher position accuracy and fewer errors than either system alone. Position accuracy is displayed in real time by the POS/MV software and was monitored to ensure that positioning accuracy requirements as outlined in the NOS Hydrographic Surveys Specifications and Deliverables were not exceeded. In addition, the POS/MV software displays HDOP and number of satellites used in position computation. Data acquisition was generally halted when an HDOP of 2.5 was exceeded or the number of satellites available dropped below four. However, because positional accuracy can be maintained by the POS/MV through short GPS outages with the help of the IMU, data acquisition was not halted during short periods of time when the HDOP and number of satellites used exceeded stated parameters.

Software:

Launch 1006 recorded Reson 8101 Shallow-water multibeam (SWMB) echosounder data, along with position and attitude data from the POS/MV using Triton-Elics’ ISIS software version 6.41 and logged in the Extended Triton Format (XTF). Due to an upgrade for precise timing, launch 1021 recorded Reson 8101 Shallow-water multibeam (SWMB) echosounder data, along with position and attitude data from the POS/MV using Triton-Elics’ ISIS software version 6.5 and logged in the Extended Triton Format (XTF).

Launches 1016 and 1015 recorded Elac 1180 Shallow-water multibeam (SWMB) echosounder data, along with position and attitude data using Elac’s Hydrostar software version 3.4.0.1 and logged in the Hydrostar exchange format (XSE).

All SWMB data were processed using the CARIS Hydrographic Information Processing System (HIPS) and Hydrographic Data Cleaning System (HDCS) software version 5.3 for the windows environment.

Coastal Oceanographic's HYPACK MAX version 02.12a was used for vessel navigation and line tracking during acquisition of SWMB data. HYPACK MAX was also used to quick mark targets that were processed as detached positions using Pydro supplied by the NOS Hydrographic Systems and Technology Programs N/CS11 (HSTP).

Sound velocity profiles were computed from raw pressure, temperature, and conductivity measurements using VelocWin 8.40 supplied by the NOS Hydrographic Systems and Technology Programs N/CS11 (HSTP).

A complete list of software and versions is included in Appendix I.

B. DATA PROCESSING AND QUALITY CONTROL

Shallow-Water Multibeam Data

Shallow-water multibeam data were monitored in real-time using the 2-D and 3-D data display windows in Isis and the on-screen display for the Reson SeaBat 8101 sonar and the Elac HydroStar Online bathymetry data display for the Elac 1180 sonar. Adjustable user parameters common for all sonars are range scale, power, gain, and pulse width. In addition the swath width and bottom slope type are additional user parameters used during acquisition for the Elac 1180. These parameters were adjusted as necessary to ensure the best data quality. Additionally, vessel speed was adjusted as necessary, and in accordance with the NOS Specifications and Deliverables and Draft Standing Project Instructions, to ensure the required along-track coverage for object detection.

Following acquisition, both Reson and Elac shallow-water multibeam data were processed using the CARIS HIPS and SIPS Batch Processor. This batch processor, running a user defined script, converted both Reson XTF data and Elac XSE data to the HDCS data format. After conversion, all soundings beyond a maximum angle of 60° off-nadir were rejected in accordance with the Draft Standing Project Instructions to reduce both the noise and refraction errors possible in the outer beams. Soundings with poor quality flags, 0 for Reson and 3 for Elac, were also rejected. As a final step of the batch processor, depth, position and attitude data were merged with sound velocity, tide, vessel offset, and dynamic draft correctors to compute the corrected depth and position of each sounding.

All data were initially reviewed with the HDCS program SwathEdit. All soundings were reviewed and obvious depth fliers were identified and manually flagged as "rejected". Vessel positioning and attitude data from each system were similarly displayed and manually cleaned. Fliers or gaps in positioning and attitude data were rejected and interpolated for small periods in time and outright rejected for larger periods in time in which the characteristic of the curve was ambiguous. Additionally, when it was felt that the quality of the data was reduced due to environmental conditions such as sea conditions or extreme variance in sound velocity, data were filtered to a lesser swath width to ensure data quality. Specific data quality factors are discussed in the Descriptive Report for each survey.

All soundings were then again reviewed, spatially referenced with the CARIS HIPS and SIPS Subset Editor. Data were compared with adjacent lines and crosslines, for systematic errors such as tide or sound velocity errors. Questionable soundings were also compared with adjacent or overlapping data for confirmation or further rejection. Depth fliers and noisy data that were not rejected in SwathEdit were rejected in Subset Mode.

Sun-illuminated Digital Terrain Model images (DTMs) were created to demonstrate coverage and to further check for systematic errors such as tide, sound velocity, or attitude and/or timing errors. DTMs for quality-assurance purposes were created using CARIS NT and a 2-meter 9-pixel resolution.

A statistical analysis of all SWMB systems is performed using the CARIS HIPS Quality Control Report (QCR) function. At the beginning of the field season, each SWMB system either ran two sets of orthogonal lines at the deeper end of its designed depth range or one set of lines over a reference surface for a beam-by-beam comparison in order to statistically determine the accuracy of each beam. Beams not meeting accuracy requirements as described in the NOS Hydrographic Surveys Specifications and Deliverables were further filtered and rejected. Results from each system's QCR can be found in Appendix IV. Additionally, a number of crosslines greater than 5% of mainscheme lines were run on each survey and manually compared to the mainscheme lines in CARIS subset mode for an additional qualitative QC comparison that is discussed in the descriptive report for each survey.

Detached Position Data

The primary purpose of detached positions (DP's) is to verify and define shoreline features (ex: rocks, reefs ledges, piles), disprove charted features, position navigational aids and landmarks (ex: buoys, beacons, lights), and mark positions of bottom samples. DPs were captured in the field as quick mark targets in HYPACK by hitting the f5 key. Additional edits to the targets (range, bearing, depth and notes) were performed by editing target parameters with the f6 key in HYPACK. Concurrent with the acquisition these DP's, digital photographs were taken of most features which were exposed above the waterline.

Following acquisition, target files (TGT) were edited when applicable to correct magnetic bearings for local variance so that all bearing were true. Additionally, DP names were changed to the format *vvvv_ddd_nnn* where *vvvv* is the vessel's hull number, *ddd* is the day of year and *nnn* is the position number (Ex: DP **1101_099_118** is the 118th position taken by vessel 1101 on day number 099). Finally the TGT files were saved with naming convention DP_*vvvv_ddd*.tgt for DPs and BS_*vvvv_ddd*.tgt for bottom samples. A vessel configuration representing the majority of the targets was selected and TGT files were converted to HDCS format data using Pydro. Digital photos were renamed to match their respective DP's fix number and moved into a single folder. Final DP attribution, correction of vessel configurations, and linkage to digital photos were the performed using Pydro. Any required application of tide and SV corrections were performed in CARIS HIPS.

S-57 Attribution

All Pydro XML features marked as "primary" were edited to have their object/attribute instances describe each feature as completely as possible. In some cases this required that multiple object classes be assigned to a single feature. Object attributes assigned to each feature conform to direction located within both the draft "S57 PYDRO guide" and the CARIS "IHO S-57/ENC Object and Attribute Catalogue".

Data Decimation and Field Sheet Production

All SWMB and VBES soundings were combined in the same HDCS project. To produce the reduced data set used to create the final field sheet, all non-rejected soundings having passed all other quality-assurance checks were imported into a Pydro Preliminary Smooth Sheet (PSS) file using shoal-biased "line-by-line" binning using a cell size of 1.5 millimeters x 1.5 millimeters at survey scale. The resultant thinned data were then excessed in Pydro using a 3-millimeter character size, ensuring that the largest spacing between selected soundings would not exceed 5 millimeters at survey scale. Final selected soundings were exported to MapInfo from Pydro using HP tools, and plotted in MapInfo at a 2-millimeter character size. Data processing flow diagrams are included in Appendix II of this report.

Pydro Processing & Reports

Pydro is capable of producing a number of different reports based on standard report templates built into the program in addition to user selected filters and feature trees. All reports generated in Pydro are saved in the Adobe Acrobat PDF format. Reports generated for inclusion with DRs include shoreline, AWOIS, DTON, and request for tides reports.

The shoreline report is generated by selecting the “For Descriptive Report” option. This generates a report detailing all features flagged “Report” in addition to all dangers to navigation.

Any item selected as a DTON must be classified as a feature in Pydro. For a sounding this is accomplished in the Pydro Feature Cumulative Grid by selecting the individual sounding of interest and with a right click “Make Feature”. The resultant feature is then flagged Primary - Significant - Chart – DTON – Resolved. Once all selected DTONs are features a report is generated by selecting Reports>Danger to Navigation. This generates both a .pdf file and an .xml file with the naming convention of “Hxxxxx_DTON1.xml. In addition, the generation of this report also flags all DTONs as Submitted. Any subsequent DTONs discovered are similarly made features and flagged as previously instructed. Running Reports>Danger to Navigation again, with the naming convention of “Hxxxxx_DTON2.xml for the second submission, will generate a report with DTONs not previously flagged as submitted.

Prior to generating an AWOIS report, the AWOIS database provided with the project instructions is edited to be sheet specific by deleting all AWOIS items which fall outside of the sheet limits. This sheet specific database is then inserted into the sheet's PSS. If a DP is taken and correlates to the AWOIS item, the DP is marked “Primary” and the corresponding AWOIS item is marked “Secondary”. If an AWOIS item was found or disproved with a multibeam sounding, the sounding is made into a bathy-feature and marked “Primary” and the corresponding AWOIS item is marked “Secondary”. Investigation techniques and methods are entered in the remarks tab of the AWOIS item. Any digital photo taken with a detached position is associated with the DP as usual. When applicable, MapInfo screengrabs displaying the AWOIS search radius with the associated grid in the background were associated with the AWOIS item. With a right mouse click “add to report” any photos or screengrabs may optionally be added to the AWOIS report. The AWOIS report is generated based on a user created feature tree which includes only AWOIS items. The AWOIS report itself is generated under Reports>For Active Tree Template. Once the Feature Report Options screen comes up “AWOIS Report” is entered under **Title**, and “AWOIS Investigations” under **Subject**. The “Show Correlating AWOIS Item # in Summary Table” and “Feature Page Breaks” options are also checked.

C. CORRECTIONS TO ECHO SOUNDINGS

Sound Velocity

Sound velocity profiles were acquired with SeaBird Electronics SeaCat SBE19 and SBE 19Plus Conductivity, Temperature, and Depth (CTD) profilers (S/N 219, 281, 4039, 4114, 4343, and 4443). Raw conductivity, temperature, and pressure data were processed using the program VelocWin version 8.40 which generated sound velocity profiles for CARIS in the .SVP format. VelocWin was also used to generate sound velocity profiles for Elac acquisition in the .SVA format. Calibration reports and dates of the SeaCat profilers are included in Appendix IV of this report.

The speed of sound through the water was determined by a minimum of one cast for every four hours of SWMB acquisition in accordance with the Standing Project Instructions and the NOS Hydrographic Surveys Specifications and Deliverables Manual. Casts were conducted more frequently when changing survey areas, or when it was felt that conditions, such as a change in weather, tide, or current, would warrant additional sound velocity profiles. Additionally, drastic changes in the surface sound velocity indicative of

the need for a new cast were determined by observation of the real-time display of the Odom Digibar Pro mounted on vessels 1016 and 1015.

The Elac 1180 SWMB system utilized on vessels 1016 and 1015 is a beam-steered flat-faced transducer system which produces the best results when SV correctors are applied to both the transducer-water interface and the water column itself. To correct SV at the face of the transducer, a real time SV value is feed directly into the HydroStar acquisition software from an Odom Digibar Pro, model db1200 velocimeter. To correct beam-steering in the water column, the .SVA file produced by VelocWin is also input into the HydroStar acquisition software and is used until replace with another .SVA file.

Occasionally circumstances would dictate taking an SV cast after the acquisition of SWMB data to which the cast was intended to be applied. In this event the cast was manually backdated so that it would be applied to the SWMB data correctly. Sound velocity profiles for CARIS were concatenated by vessel in order of ascending time/date and saved in the same directory as the individual SVP files for each vessel. A naming convention of Hxxxxx_vvvv_SVP.SVP was used where Hxxxxx is the sheet's registry number and vvvv is the vessel's hull number (Ex: **H11292_1006_SVP.SVP** is the concatenated SVP file for hull number 1006 for sheet H11292). This concatenated file was then applied to all HDCS data collected by that particular vessel with the option **Previous in time** selected under the **Profile Selection Method**.

Vessel Offsets and Dynamic Draft Correctors

The following table shows when the vessel offsets and dynamic draft correctors used for this project were last determined:

Vessel Hull Number	Date of Static Draft and Transducer Offset Measurements	Method of Settlement and Squat Measurement	Date of Settlement and Squat Measurement	Location of Settlement and Squat Measurement
1021	March 2004	Surface analysis	March 2004	Lake Washington, WA
1016	March 2004	Surface analysis	March 2004	Lake Washington, WA
1006	March 2004	Surface analysis	March 2004	Lake Washington, WA
1015	March 2004	Surface analysis	March 2004	Lake Washington, WA

Settlement and squat observations were conducted for all launches using a surface analysis method. An area of flat topography was selected in a lake to negate any tidal influence. A line was then run repeatedly in the same direction at different speeds while logging data. Finally data was collected at three pre-selected target areas on the same line while the launch was at rest. Settlement and squat speed curves were derived by querying these target areas using CARIS and graphing the change of apparent depth at different speeds.

Vessel offsets and static draft were measured using both steel tapes and a LEICA laser distance meter. In most cases, measurement values obtained fell close to the historic values and these were retained. In a few cases, the new measurements differed enough from the historic values and the new measurements were carried forward.

Dynamic draft and vessel offsets corrector values are stored in CARIS Vessel Configuration Files (VCFs). Survey platforms used to collect SWMB data each have a separate VCF associated with each individual acquisition system aboard. Each of these VCFs contain sensor offset and dynamic draft correctors that pertain to this single acquisition system. Sensor offset and dynamic draft correctors were applied to SWMB data in CARIS during post-processing. Vessel offset diagrams and dynamic draft tables are included in Appendix III of this report. The VCFs themselves are submitted with the digital HDCS data.

The following table lists each Vessel Configuration File used for this project:

VCF name	Survey Vessel & System Type
1021_Reson8101	Jensen hull 1021, Swing-arm mounted Reson 8101
1016_Elac1180	Jensen hull 1016, Hull mounted Elac 1180
1006_Reson8101	Jensen hull 1006, Hull mounted Reson 8101
1015_Elac1180	Jensen hull 1015, Hull mounted Elac 1180

Heave, Pitch, Roll and Heading, Including Biases and Navigation Timing Errors

SWMB launches (Vessels 1021, 1016, 1006 and 1015) utilized a TSS POS/MV Model 320 Position and Orientation System – Marine Vessel (POS/MV) which provides accurate navigation and attitude data to correct for the effects of heave, pitch, roll and heading. The POS generates attitude data in three axes (roll, pitch and heading) to an accuracy of 0.05° or better. Heave measurements supplied by the POS/MV maintain an accuracy of 5% of the measured vertical displacement for movements that have a period of up to 20 seconds. The POS/MV delivers heading measurements by two distinct methods. First, the Dynamic Heading Alignment determines the vessels heading by using the data supplied by the Internal Measurement Unit (IMU) and GPS receivers to achieve heading that is, at best, accurate to within 0.25° . This method suffers from drift but is relatively unaffected by noise. Second, the GPS Azimuth Measurement System (GAMS) determines the geographic vector between two GPS antennas fixed to the vessel by comparing the phase of satellite signals they receive. The error from this method is largely due to noise, but exhibits no drift. The POS/MV uses the advantages of each method to compensate for the disadvantages of the other to arrive at an optimal accuracy of 0.05° .

With a series of both software and firmware upgrades in addition to modified wiring, hull 1021 was upgraded for precise timing on March 14th. The objective of this upgrade is to use a single clock to time stamp all data at the point of acquisition and thus eliminate the latencies introduced by the serial and Ethernet interfaces in addition to the PC millisecond counter. Position, heading and attitude are all time stamped by the POS/MV on UTC epoch and the bathy data is time stamped in SeaBat using the POS/MV UTC serial string. This synchronization essentially eliminates timing errors and variable latencies resulting in data which is both horizontally and vertically more accurate.

Prior to commencement of survey operations, Reson multibeam sonar calibration was conducted. Heave, roll, pitch, and navigation latency lines were run in accordance with section 5.5.1 of the NOS Hydrographic Specifications and Deliverables. Biases were determined in the order navigation timing error, pitch, roll, and finally heading.

Patch test procedures are modified slightly for precise timing. Pitch, roll and yaw lines are collected and processed as usual in accordance with NOS Hydrographic Specifications and Deliverables. Navigation latency is determined by examination of the roll timing error. Roll error can be determined from any single line in an area with relatively flat topography. A thin slice of the outer beams parallel to the line was examined in CARIS calibration mode. Any wavelike pattern observed in the data is assumed to be the result of roll latency. The roll latency value is determined by manually changing the value until the wave pattern disappears. The resultant latency value was also applied to navigation, heave gyro and pitch time errors since they all of these values are produced by the POS/MV.

Elac patch test procedures were modified as outlined in section 3.7.3 of the HydroStar Manuals 2.1. Since the Elac is a beam-steered flat-faced transducer system, the roll bias values must be entered directly into the

HydroStar acquisition software for proper beam steering calculations. Roll bias values are not entered into the CARIS Vessel Configuration Files (VCFs) so as to avoid double application. The transducer alignment option in HydroStar allows for automated computation of the roll bias values based upon two pairs of reciprocal lines in an area with flat seafloor, one offset from the other to ensure an overlap of 100%. Pitch, yaw and navigation latency lines are collected and processed as usual in accordance with NOS Hydrographic Specifications and Deliverables.

All SWMB vessel offsets, dynamic draft correctors, and system bias values (except for Elac roll bias) are contained in CARIS Vessel Configuration Files (VCFs) and were created using the program Vessel Editor in CARIS. These offsets and biases are applied to the sounding data during processing in CARIS. All applicable VCFs are included with the digital HDCS data.

Water Level Correctors

Soundings were reduced to Mean Lower-Low Water (MLLW) using unverified observed tide data for stations at Port Townsend, WA (944-4900), Friday Harbor, WA (944-9880), and Port Angeles, WA (944-4090). Tide data were obtained from the Center for Operational Oceanographic Products and Services (CO-OPS) web site through TideBot. These data were used in creating the observed tide corrector tables (*.tid files) in CARIS. Raw observed water level data from these three reference stations were applied to the survey depths in CARIS using height ratio and time correctors from the CO-OPS provided zone definition file (*.zdf).

Refer to the Horizontal and Vertical Control Report for specific information on the tidal gauges used in during this project and individual Descriptive Reports for further information regarding water level correctors specific to each survey.

D. APPROVAL

As Chief of Party, I have ensured that standard field surveying and processing procedures were used during this project in accordance with the Hydrographic Manual, Fourth Edition; Hydrographic Survey Guidelines; Field Procedures Manual, and the NOS Hydrographic Surveys Specifications and Deliverables Manual, as updated for 2003.

I acknowledge that all of the information contained in this report is complete and accurate to the best of my knowledge.

Approved and Forwarded:

John W. Humphrey
Commander, NOAA
Commanding Officer

In addition, the following individual was also responsible for overseeing data acquisition and processing of this project:

Field Operations Officer:

Kevin J. Slover
Lieutenant, NOAA

Chief Survey Technician:

James B. Jacobson
Chief Survey Technician, NOAA

APPENDIX I

Software Versions and Hardware Serial Numbers

Software Versions

		version	service pack	hot fix	other	date	comments
Acquisition	Hypack Max	02.12a			build 2.12.52.0	3/15/04	
	POS/MV controller v2	3.0				3/15/04	
	POS/MV controller v3	2.1				3/15/04	
	Isis	6.41 6.5				3/14/04 3/14/04 7/1/04	1021 only 1016 & 1006
	Hydostar	3.4.0.1				3/15/04	
	Sonar Pro (for Klein 3000)	6.4				3/15/04	
Processing	CARIS GIS	4.4a	3 4	10 11-29 1-8		3/15/04 4/22/04 8/2/04	
	HIPS/SIPS	5.3 5.4	3 1	25 1-7 7-12 13-14 1-2	Elac SV patch XTF converter patch Elac imagery patch	3/11/04 4/8/04 4/9/04 4/20/04 5/27/04 6/1/04 6/14/04 6/26/04 8/2/04	2-part install for Reson 8125 fixes backscatter 2 computers only
	Pydro	3.7.1 4.4.1 4.4.4 4.6.1 4.7.1				4/9/04 5/9/04 7/22/04 8/2/04	BASE support
	Python	2.2.2 2.3.3				3/15/04 4/9/04	for new Pydro
	wxPython	2.4.0.7 2.4.2.4				3/15/04 4/9/04	for new Pydro
	HP Tools	3.7.3 3.8.1				3/15/04 4/9/04	
	KapConv	3.9.1				3/15/04	
	NOAA Chart Reprojector	2.0.2a				3/15/04	
	MapInfo	6.5			build 19	3/15/04	
	Vertical Mapper	3.0			build 3.0.0.019	3/15/04	
	Fledermaus	5.1.2 6.1.0				3/15/04 5/13/04	Windows ver.
	Exceed	7.1.1				3/15/04	for Fledermaus

Horizontal Control	TSIP Talker	2.00				3/15/04	
	DSX/National Geodetic Society DSData Extraction	6.04				3/15/04	
	GPPS/Geodetic Post Processing Software	5.0.00				3/15/04	
	Ashtech Mission Planner	4.50				3/15/04	
	Fillnet	3.1				3/15/04	
	Vertical Control	Sound Velocity					
VelocWin		8.4				3/15/04	
SBE SeaTerm		1.3				3/15/04	
Leveling							
Newiz		2.0				3/15/04	for PocketPC
Tides							
LogPlot		1.4				3/15/04	
LogStats		1.1				3/15/04	
LogPrn Convert	1.9				3/15/04	2 to 4 digit year	
Utilities	Tides and Currents	2.5b				3/15/04	
	Winzip	9				3/15/04	large file support

Description	Vessel	Serial Number
Knudsen Engineering Limited 320M Marine Echosounders	Spare	K96388
	1101	K99323
	1103	K98579
	1021	none aboard
	1016	K99322
	1006	K96387
	1015	K99324
RESON 8101 SONAR Processor	1021	17005
	1006	31676
RESON Seabat 81-P Sonar Processor (for 8125)	1016	29979
Seabeam/Elac 1180	1015	76
	1016	77
	S221	62
Trimble DSM212L	Spare	0220157914
	1101	0220159717
	1103	0220159719
	S221	0220157923
csi Wireless MBX-3S	1021	0324-11969-0002
Trimble ProBeacon	1016	0220238661
	1006	0220242435
	1015	0220238662
	S221	0220238648
TSS Position & Orientation System POS/MV V2	1015	021
TSS Position & Orientation System POS/MV V3	1021	507
	1016	295
	1006	304
TSS IMU	1021	305
	1016	131
	1006	28
	1015	37
Digibar Pro	1016	98015
	1015	98016
TSS/MAHRS	S221	003008

APPENDIX II

Data Processing Flow Diagrams

Raw sounding data to HDCS

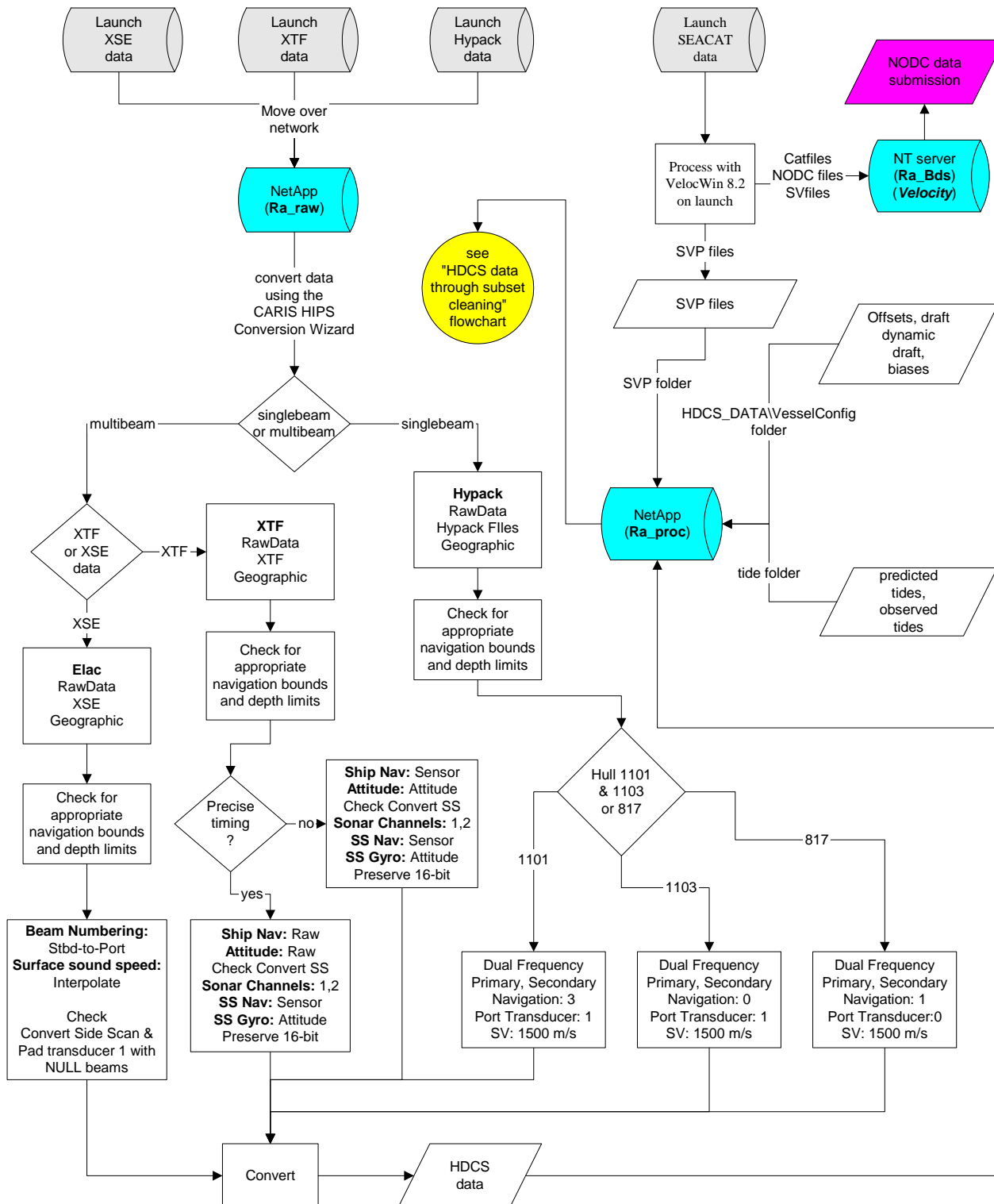

Detached Position processing (Raw DP's to Pydro)

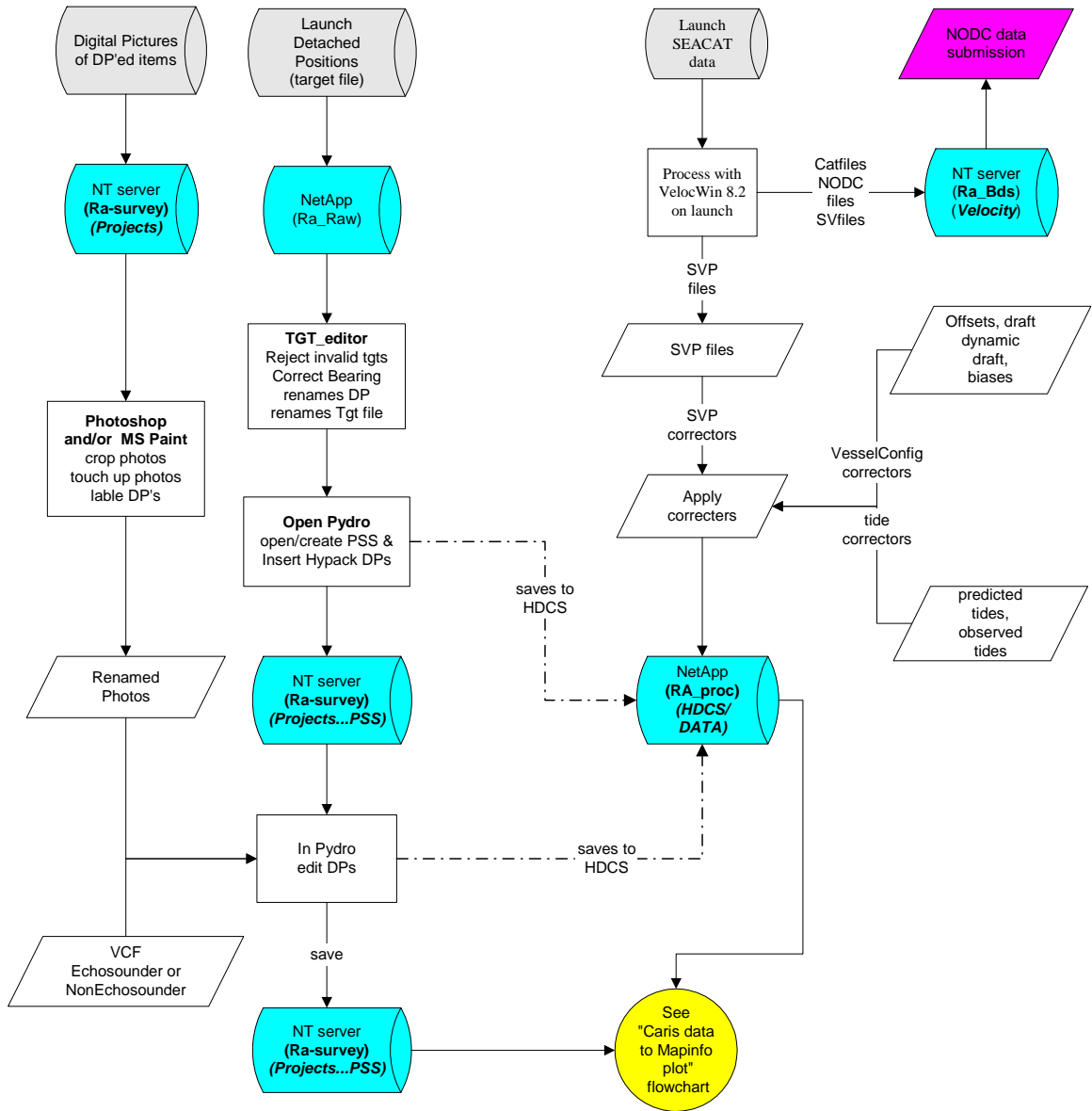

Detached Position processing in Pydro

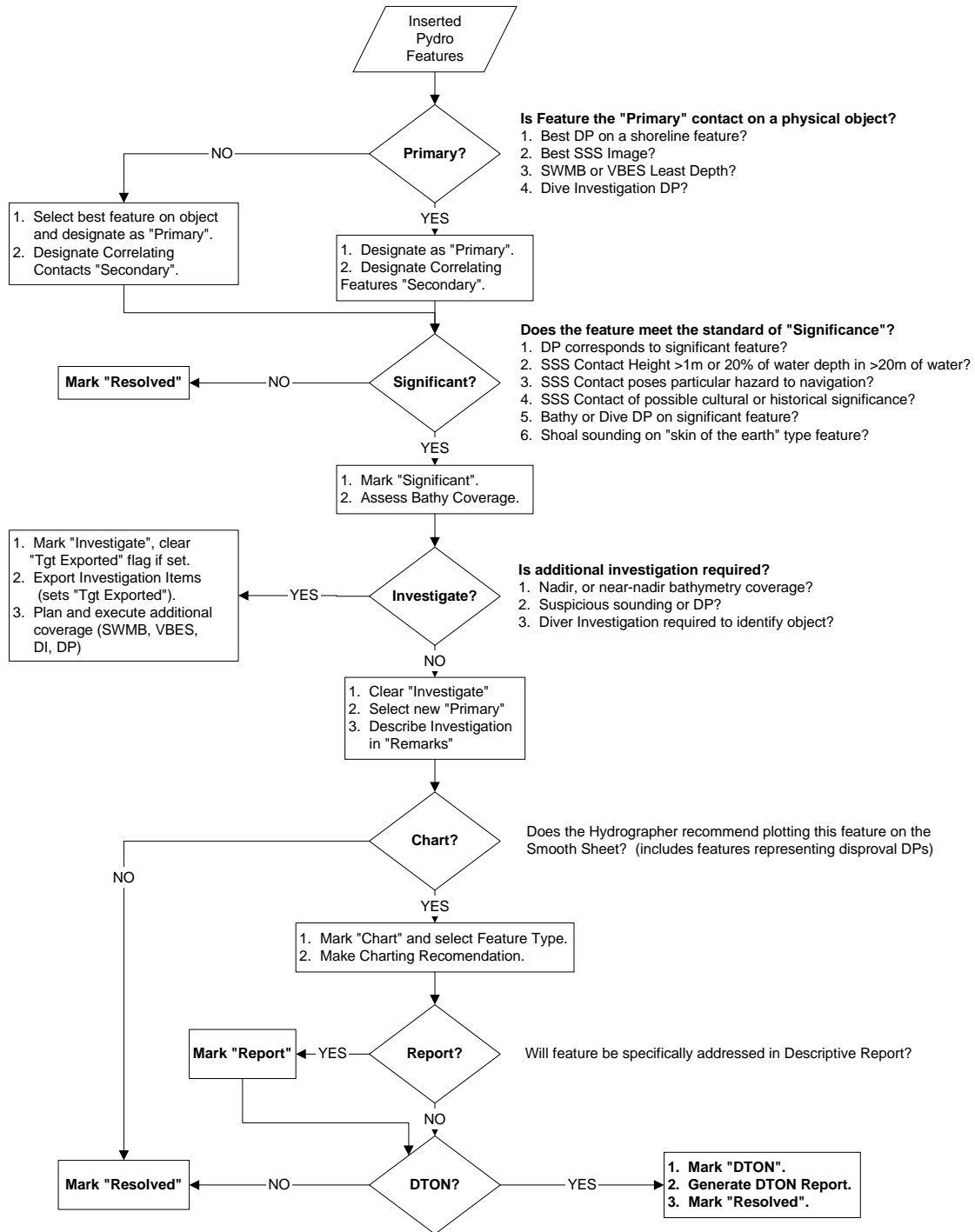

HDCS data through subset cleaning

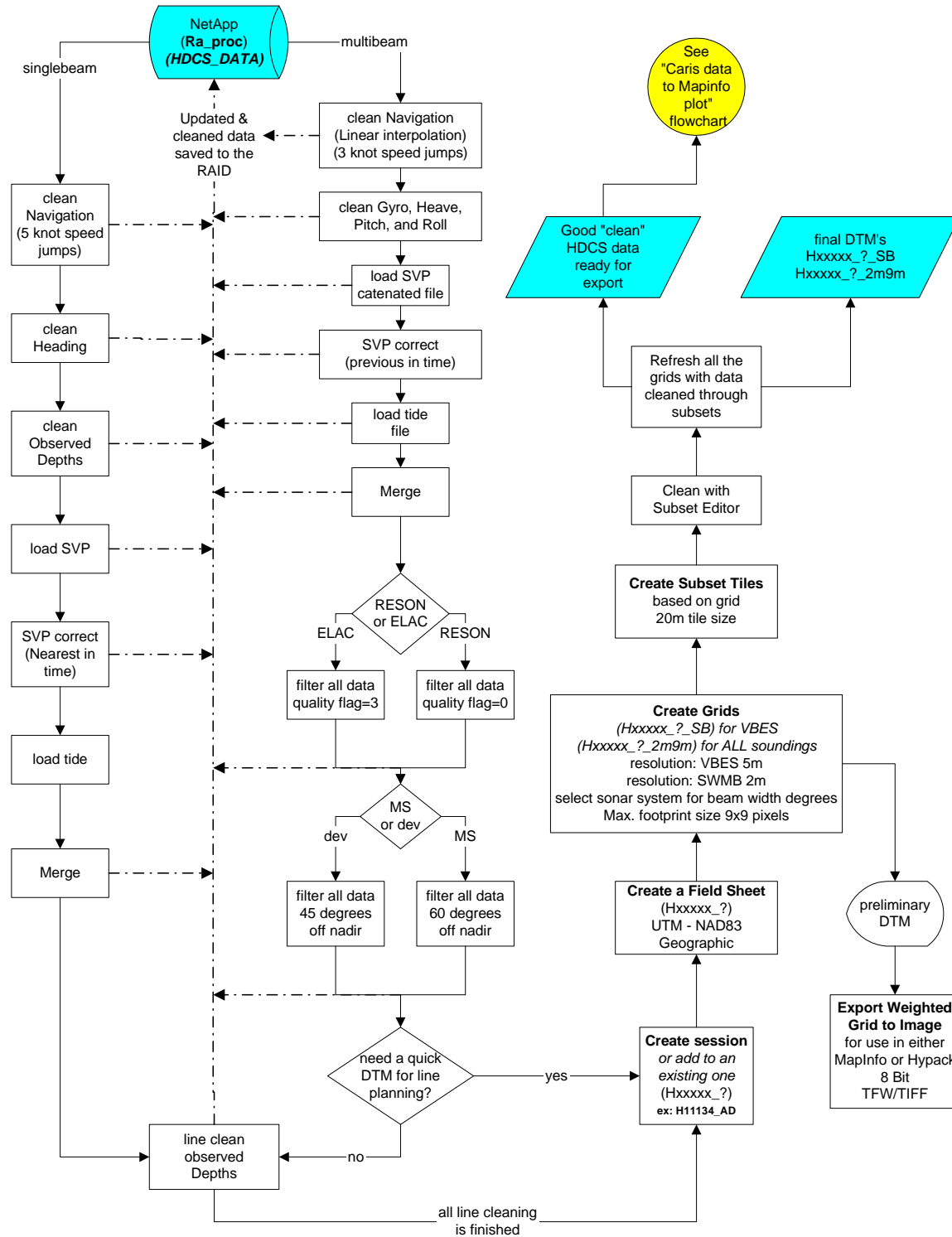

Caris data to MapInfo plot

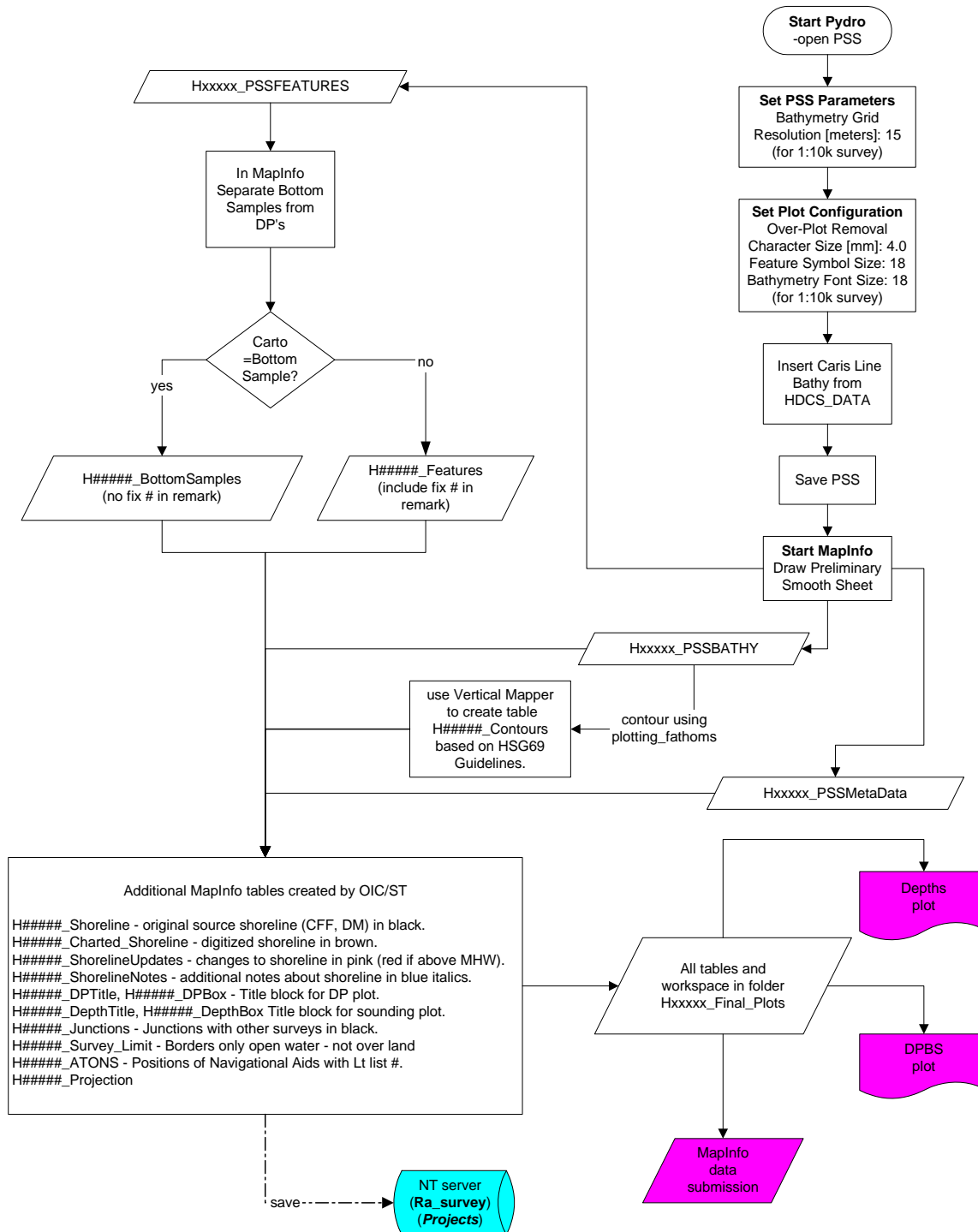

APPENDIX III

Vessel Offset Diagrams CARIS Vessel Reports

CARIS Offset Sign Conventions

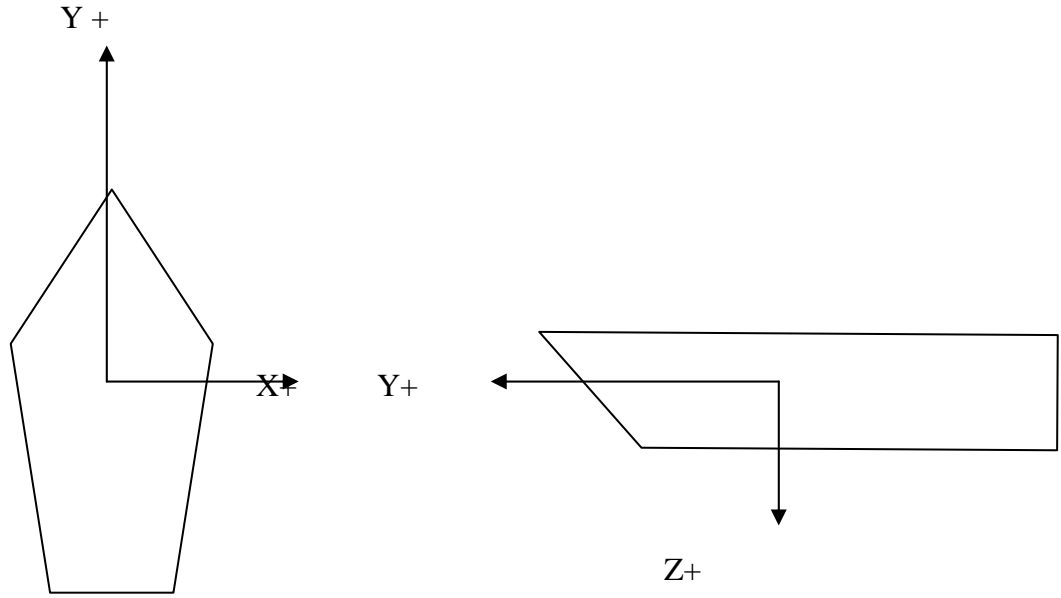

Hull 1021 (RA3) Vessel Offset Measurements

7/10/2004

Description: Aluminum Jensen survey launch

LOA: 29 feet

Weigh: 14,000 lbs

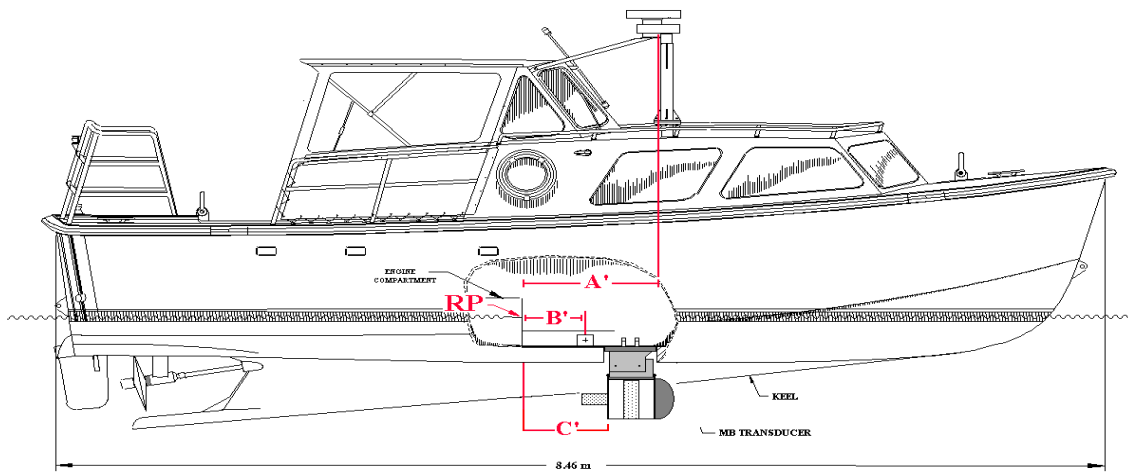

* Assume RP at waterline & centerline of engine bulkhead

		Y (along-ship)	
		cm.	date measured
RP to GPS	A'	85.0	Mar-04
RP to MRU	B'	49.0	Mar-04
RP to SWMB ducer	C'	34.4	Mar-04

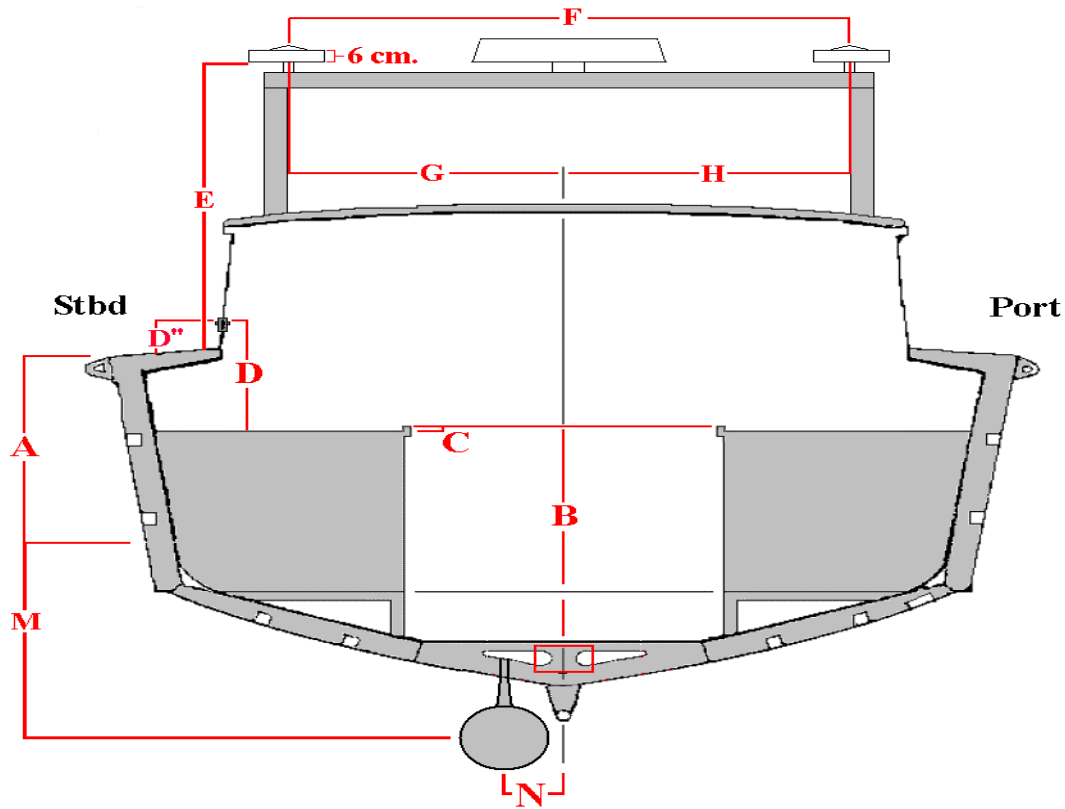

		X (athwartship)		Z (vertical)	
		cm.	date measured	cm.	date measured
Waterline to deck	A	n/a	n/a	98.3	Mar-04
MRU to counter top rail	B	n/a	n/a	97.2	Mar-04
Countertop rail to countertop	C	n/a	n/a	1.9	Mar-04
Countertop to thru-bulkhead fitting	D	n/a	n/a	70.9	Mar-04
Thru-bulkhead fitting to deck	D"	n/a	n/a	44.3	Mar-04
Deck to bottom of GPS	E	n/a	n/a	174.4	Mar-04
GPS to GPS	F	172.1	Mar-04	n/a	n/a
Centerline to Stbd GPS	G	86.1	Mar-04	n/a	n/a
Centerline to Port GPS	H	86.0	Mar-04	n/a	n/a
Waterline to SWMB transducer	M	67.2	Mar-04	n/a	n/a
Centerline to SWMB transducer	N	32.6	Mar-04	n/a	n/a

CARIS configuration is based on a Reference Position (RP)
 RP is assumed to be centerline, at the waterline, on the forward side
 of the bulkhead separating the engine compartment from the cabin

X athwartship distance [+ starboard]
Y along-ship distance [+ towards bow]
Z vertical distance [+ into water]

X	SWMB-ducer offset	0.33	Swath 1
	MRU to RP (mounted centerline)	0.00	
Y	RP to MB-ducer (equals C')	0.34	Navigation Gyro Heave Pitch Roll
	RP to MRU (equals B')	0.49	
Z	MB-ducer to RP (equals M)	0.67	
	MRU to RP (equals B+D-C-D"-A)	0.24	

Vessel Name: 1021_Reson8101
Vessel created: March 17, 2004

Depth Sensor:

Sensor Class: Swath
 Time Stamp: 2004-076 00:00

Transducer #1:

Pitch Offset: 0.710
 Roll Offset: 0.150
 Azimuth Offset: 0.080

DeltaX: 0.330
 DeltaY: 0.340
 DeltaZ: 0.670

Manufacturer:
 Model: Unknown
 Serial Number:

Navigation Sensor:

Time Stamp: 2004-076 00:00

Comments
 Latency 0.060
 DeltaX: 0.000
 DeltaY: 0.490
 DeltaZ: 0.240

Manufacturer: (null)
 Model: (null)
 Serial Number: (null)

Gyro Sensor:

Time Stamp: 2004-076 00:00

Comments
 Latency 0.060

Entry 0) Draft: 0.000 Speed: 0.000

Heave Sensor:

Time Stamp: 2004-076 00:00

Comments
 Apply Yes
 Latency 0.060
 DeltaX: 0.000

DeltaY: 0.490
DeltaZ: 0.240

Manufacturer: (null)
Model: (null)
Serial Number: (null)

Pitch Sensor:

Time Stamp: 2004-076 00:00

Comments
Apply Yes
Latency 0.060
Pitch offset: 0.000

Manufacturer: (null)
Model: (null)
Serial Number: (null)

Roll Sensor:

Time Stamp: 2004-076 00:00

Comments
Apply Yes
Latency 0.060
Roll offset: 0.000

Manufacturer: (null)
Model: (null)
Serial Number: (null)

Draft Sensor:

Time Stamp: 2004-076 00:00

Apply Yes
Comments
Entry 1) Draft: 0.000 Speed: 0.000
Entry 2) Draft: 0.000 Speed: 2.200
Entry 3) Draft: 0.010 Speed: 4.300
Entry 4) Draft: 0.020 Speed: 5.000
Entry 5) Draft: 0.030 Speed: 5.400
Entry 6) Draft: 0.050 Speed: 6.400
Entry 7) Draft: 0.060 Speed: 7.100
Entry 8) Draft: 0.070 Speed: 7.800
Entry 9) Draft: 0.060 Speed: 8.400
Entry 10) Draft: 0.040 Speed: 9.100

Svp Sensor:

Time Stamp: 2004-076 00:00

Comments

Svp #1:

Pitch Offset: 0.000

Roll Offset: 0.000

Azimuth Offset: 0.000

DeltaX: 0.000

DeltaY: 0.000

DeltaZ: 0.000

SVP #2:

Pitch Offset: 0.000

Roll Offset: 0.000

Azimuth Offset: 0.000

DeltaX: 0.330

DeltaY: 0.340

DeltaZ: 0.670

Hull 1016 (RA4) Vessel Offset Measurements, Elac 1180

9/12/2004

Description: Aluminum Jensen survey launch

LOA: 29 feet

Weigh: 14,000 lbs

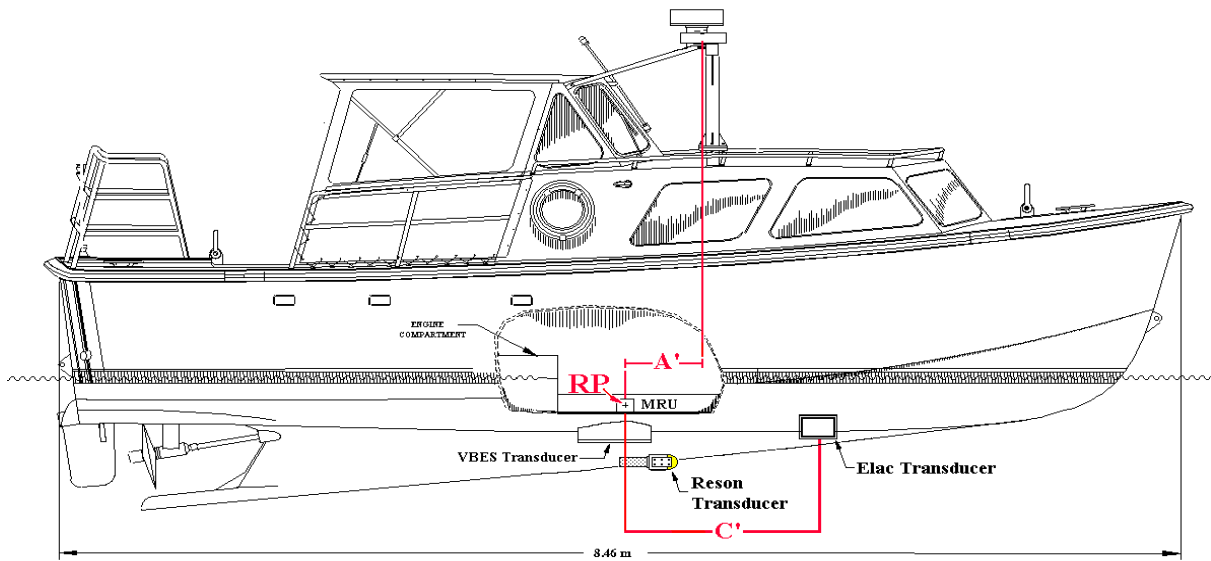

* Assume RP at waterline & centerline of engine bulkhead

		Y (along-ship)	
		cm.	date measured
RP to GPS	A'	35.0	May-00
RP to Elac ducer	C'	156.0	May-00

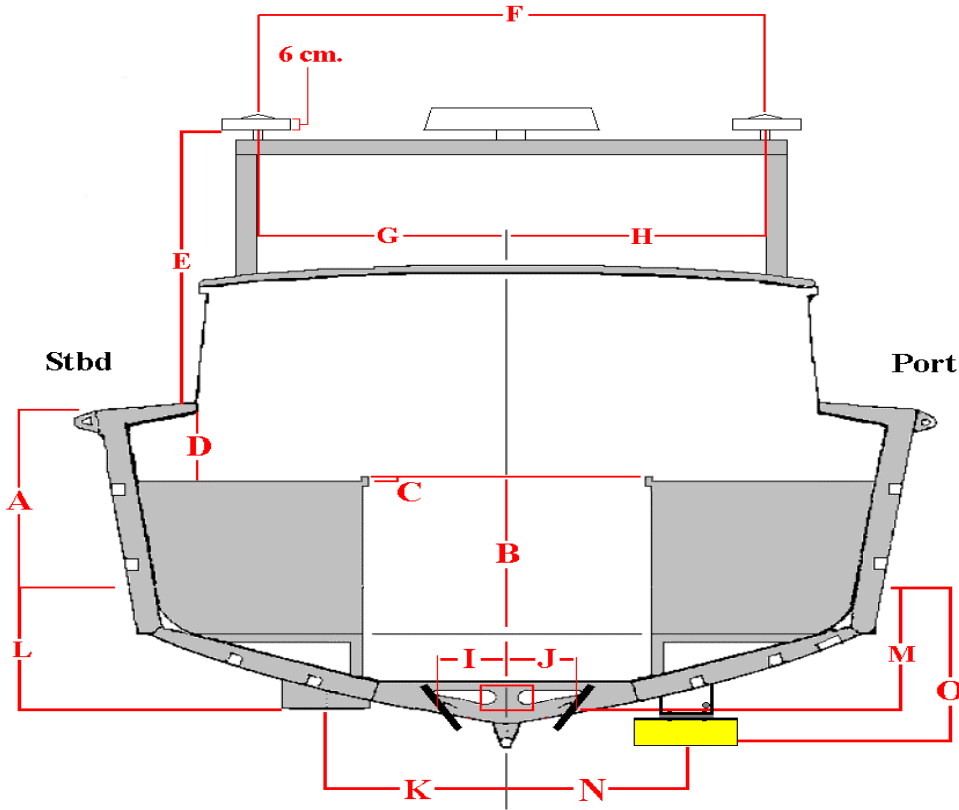

		X (athwartship)		Z (vertical)	
		cm.	date measured	cm.	date measured
Waterline to deck	A	n/a	n/a	96.5	May-00
MRU to counter top rail	B	n/a	n/a	104.9	May-00
Countertop rail	C	n/a	n/a	0.0	May-00
Countertop to deck	D	n/a	n/a	21.8	May-00
Deck to bottom of GPS	E	n/a	n/a	170.9	May-00
Waterline to VBES transducer	L	n/a	n/a	61.0	Mar-98
Waterline to Elac transducer	M	n/a	n/a	57.0	May-00
Waterline to Reson transducer	O	n/a	n/a	76.0	May-03
GPS to GPS	F	174.5	May-00	n/a	n/a
Centerline to Stbd GPS	G	87.5	May-00	n/a	n/a
Centerline to Port GPS	H	87.0	May-00	n/a	n/a
Centerline to Stbd Elac ducer	I	33.3	May-00	n/a	n/a
Centerline to Port Elac ducer	J	33.4	May-00	n/a	n/a
Centerline to VBES transducer	K	34.9	May-00	n/a	n/a
Centerline to Reson transducer	N	38.0	May-03	n/a	n/a

CARIS configuration is based on a Reference Position (RP)
 The RP has been defined to coincide with the location of the MRU

X athwartship distance [+ starboard]
Y along-ship distance [+ towards bow]
Z vertical distance [+ into water]

X	Elac transducer offset (equals average I & J)	+/-	0.33	Swath 1 Swath 2
	MRU to RP (mounted centerline)		0.00	
Y	RP to Elac transducer (equals C')		1.56	Navigation Gyro Heave Pitch Roll
	RP to MRU (equals B')		0.00	
Z	Elac transducer to RP (equals M-(B+D-C-A))		0.27	
	MRU to RP (equals B+D-C-A)		0.00	
	MRU to waterline (equals A-D+C-B)		-0.30	Waterline

Vessel Name: 1016_Elac1180
Vessel created: August 24, 2004

Depth Sensor:

Sensor Class: Swath
Time Stamp: 2004-076 00:00

Transducer #1:

Pitch Offset: 0.400
Roll Offset: 0.000
Azimuth Offset: -1.500

DeltaX: 0.330
DeltaY: 1.560
DeltaZ: 0.270

Manufacturer:
Model: Unknown
Serial Number:

Transducer #2:

Pitch Offset: -0.100
Roll Offset: 0.000
Azimuth Offset: -2.500

DeltaX: -0.330
DeltaY: 1.560
DeltaZ: 0.270

Manufacturer:
Model: Unknown
Serial Number:

Navigation Sensor:

Time Stamp: 2004-076 00:00

Comments
Latency 0.060
DeltaX: 0.000
DeltaY: 0.000
DeltaZ: 0.000

Manufacturer: (null)
Model: (null)
Serial Number: (null)

Gyro Sensor:

Time Stamp: 2004-076 00:00

Comments
Latency 0.060

Entry 0) Draft: 0.000 Speed: 0.000

Heave Sensor:

Time Stamp: 2004-076 00:00

Comments
Apply Yes
Latency 0.060
DeltaX: 0.000
DeltaY: 0.000
DeltaZ: 0.000

Manufacturer: (null)
Model: (null)
Serial Number: (null)

Pitch Sensor:

Time Stamp: 2004-076 00:00

Comments
Apply Yes
Latency 0.060
Pitch offset: 0.000

Manufacturer: (null)
Model: (null)
Serial Number: (null)

Roll Sensor:

Time Stamp: 2004-076 00:00

Comments
Apply Yes
Latency 0.060
Roll offset: 0.000

Manufacturer: (null)
Model: (null)
Serial Number: (null)

Draft Sensor:

Time Stamp: 2004-076 00:00

Apply Yes
Comments
Entry 1) Draft: 0.000 Speed: 0.000
Entry 2) Draft: 0.010 Speed: 2.200
Entry 3) Draft: 0.020 Speed: 4.000

Entry 4) Draft: 0.030	Speed: 5.000
Entry 5) Draft: 0.040	Speed: 5.700
Entry 6) Draft: 0.070	Speed: 6.800
Entry 7) Draft: 0.090	Speed: 7.500
Entry 8) Draft: 0.100	Speed: 7.900
Entry 9) Draft: 0.090	Speed: 8.300
Entry 10) Draft: 0.040	Speed: 9.800

Svp Sensor:

Time Stamp: 2004-076 00:00

Comments

Svp #1:

Pitch Offset: 0.000
Roll Offset: 38.000
Azimuth Offset: 0.000

DeltaX: -0.330
DeltaY: 1.560
DeltaZ: 0.270

SVP #2:

Pitch Offset: 0.000
Roll Offset: -38.000
Azimuth Offset: 0.000

DeltaX: 0.330
DeltaY: 1.560
DeltaZ: 0.270

WaterLine:

Time Stamp: 2004-076 00:00

Comments

Apply Yes

WaterLine -0.300

WaterLineStdDev 0.000

Hull 1006 (RA5) Vessel Offset Measurements, Reson 8101

7/10/2004

Description: Aluminum Jensen survey launch

LOA: 29 feet

Weigh: 14,000 lbs

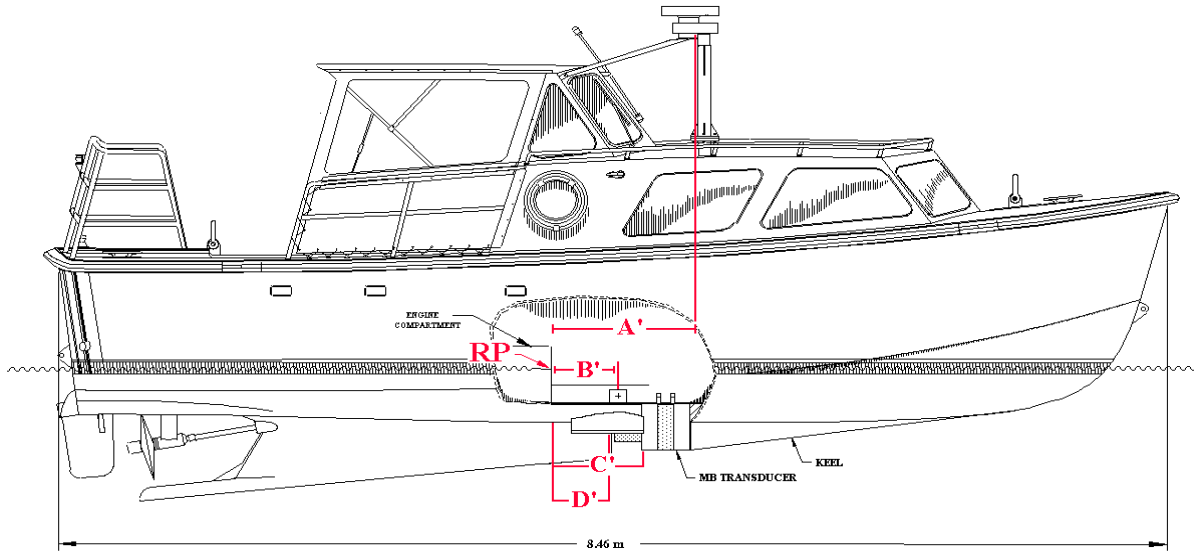

* Assume RP at waterline & centerline of engine bulkhead

		Y (along-ship)	
		cm.	date measured
RP to GPS	A'	92.0	Mar-04
RP to MRU	B'	48.0	Mar-04
RP to SWMB ducer	C'	73.3	Mar-99
RP to VBES ducer	D'	40.5	May-00

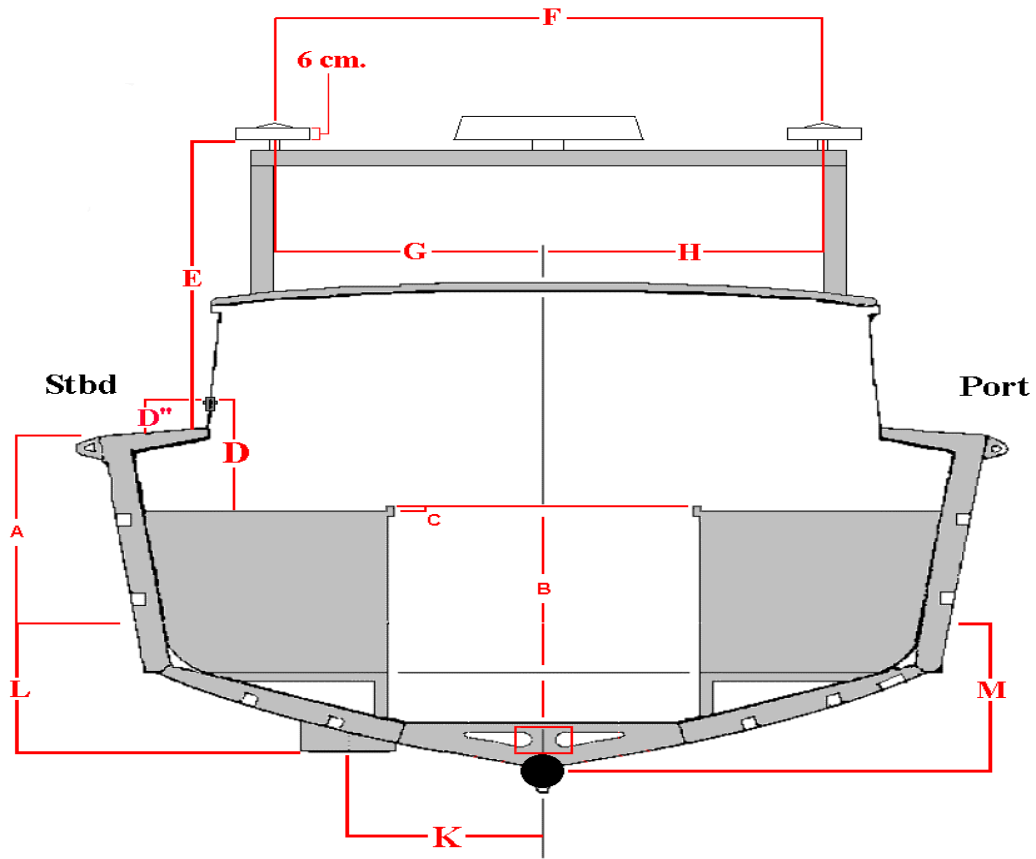

		X (athwartship)		Z (vertical)	
		cm.	date measured	cm.	date measured
Waterline to deck	A	n/a	n/a	100.0	Mar-99
MRU to counter top rail	B	n/a	n/a	105.2	Mar-04
Countertop rail to countertop	C	n/a	n/a	1.9	Mar-04
Countertop to thru-bulkhead fitting	D	n/a	n/a	46.5	Mar-04
Thru-bulkhead fitting to deck	D"	n/a	n/a	29.0	Mar-04
Deck to bottom of GPS	E	n/a	n/a	177.0	Mar-04
Waterline to SWMB transducer	M	n/a	n/a	49.6	Mar-99
Waterline to VBES transducer	L	n/a	n/a	53.0	Apr-98
GPS to GPS	F	181.7	Mar-04	n/a	n/a
Centerline to Stbd GPS	G	90.0	Apr-98	n/a	n/a
Centerline to Port GPS	H	91.0	Apr-98	n/a	n/a
Centerline to VBES transducer	K	50.5	Mar-04	n/a	n/a

CARIS configuration is based on a Reference Position (RP)
 RP is assumed to be centerline, at the waterline, on the forward side
 of the bulkhead separating the engine compartment from the cabin

X athwartship distance [+ starboard]
Y along-ship distance [+ towards bow]
Z vertical distance [+ into water]

X	SWMB-ducer offset (mounted centerline)	0.00	Swath 1
	MRU to RP (mounted centerline)	0.00	
Y	RP to MB-ducer (equals C')	0.73	Navigation Gyro Heave Pitch Roll
	RP to MRU (equals B')	0.48	
Z	MB-ducer to RP (equals M)	0.50	
	MRU to RP (equals B+D-C-D"-A)	0.21	

Vessel Name: 1006_Reson8101
Vessel created: March 18, 2004

Depth Sensor:

Sensor Class: Swath
Time Stamp: 2004-076 00:00

Transducer #1:

Pitch Offset: 2.010
Roll Offset: -0.850
Azimuth Offset: 0.590

DeltaX: 0.000
DeltaY: 0.730
DeltaZ: 0.500

Manufacturer: Reson
Model: 8101
Serial Number: 31676

Navigation Sensor:

Time Stamp: 2004-076 00:00

Comments
Latency 0.000
DeltaX: 0.000
DeltaY: 0.480
DeltaZ: 0.210

Manufacturer: POS/MV
Model: 320
Serial Number: 304

Gyro Sensor:

Time Stamp: 2004-076 00:00

Comments
Latency 0.000

Entry 0) Draft: 0.000 Speed: 0.000

Heave Sensor:

Time Stamp: 2004-076 00:00

Comments
Apply Yes
Latency 0.000
DeltaX: 0.000

DeltaY: 0.480
 DeltaZ: 0.210

Manufacturer: POS/MV
 Model: 320
 Serial Number: 304

Pitch Sensor:

Time Stamp: 2004-076 00:00

Comments
 Apply Yes
 Latency 0.000
 Pitch offset: 0.000

Manufacturer: POS/MV
 Model: 320
 Serial Number: 304

Roll Sensor:

Time Stamp: 2004-076 00:00

Comments
 Apply Yes
 Latency 0.000
 Roll offset: 0.000

Manufacturer: POS/MV
 Model: 320
 Serial Number: 304

Draft Sensor:

Time Stamp: 2004-076 00:00

Apply Yes
 Comments
 Entry 1) Draft: 0.000 Speed: 0.000
 Entry 2) Draft: 0.000 Speed: 2.000
 Entry 3) Draft: 0.030 Speed: 4.000
 Entry 4) Draft: 0.070 Speed: 5.200
 Entry 5) Draft: 0.080 Speed: 5.700
 Entry 6) Draft: 0.090 Speed: 6.400
 Entry 7) Draft: 0.110 Speed: 6.900
 Entry 8) Draft: 0.120 Speed: 7.400
 Entry 9) Draft: 0.110 Speed: 7.900
 Entry 10) Draft: 0.100 Speed: 8.700

Svp Sensor:

Time Stamp: 2004-076 00:00

Comments

Svp #1:

Pitch Offset: 0.000

Roll Offset: 0.000

Azimuth Offset: 0.000

DeltaX: 0.000

DeltaY: 0.000

DeltaZ: 0.000

SVP #2:

Pitch Offset: 0.000

Roll Offset: 0.000

Azimuth Offset: 0.000

DeltaX: 0.000

DeltaY: 0.730

DeltaZ: 0.500

Hull 1015 (RA6) Vessel Offset Measurements, Elac 1180

9/12/2004

Description: Aluminum Jensen survey launch

LOA: 29 feet

Weigh: 14,000 lbs

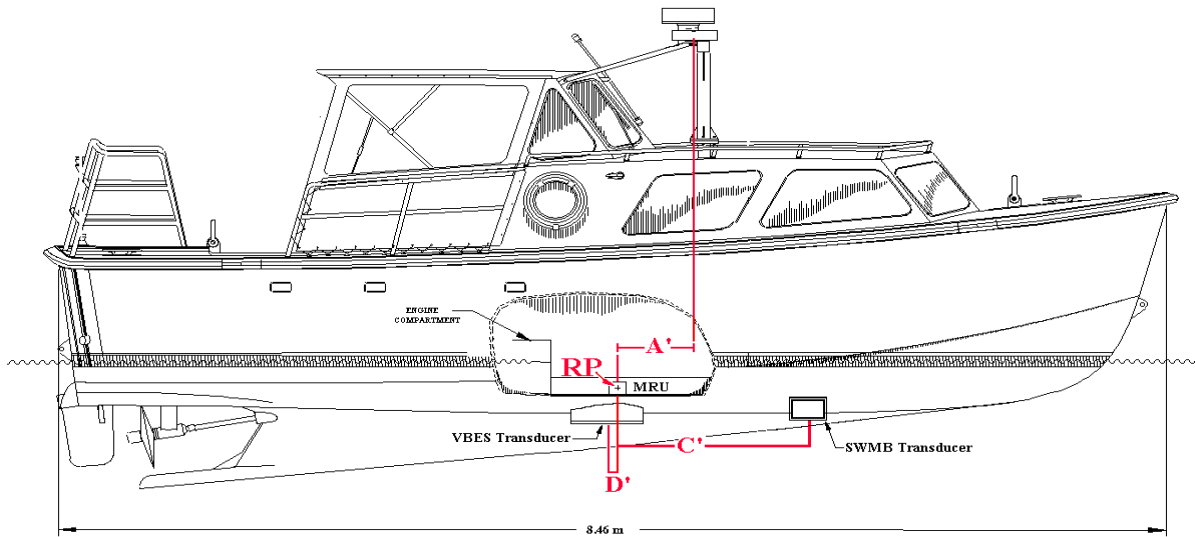

* Assume RP at waterline & centerline of engine bulkhead

		Y (along-ship)	
		cm.	date measured
RP to GPS	A'	51.2	May-00
RP to SWMB ducer	C'	156.0	May-00
RP to VBES ducer	D'	3.2	May-00

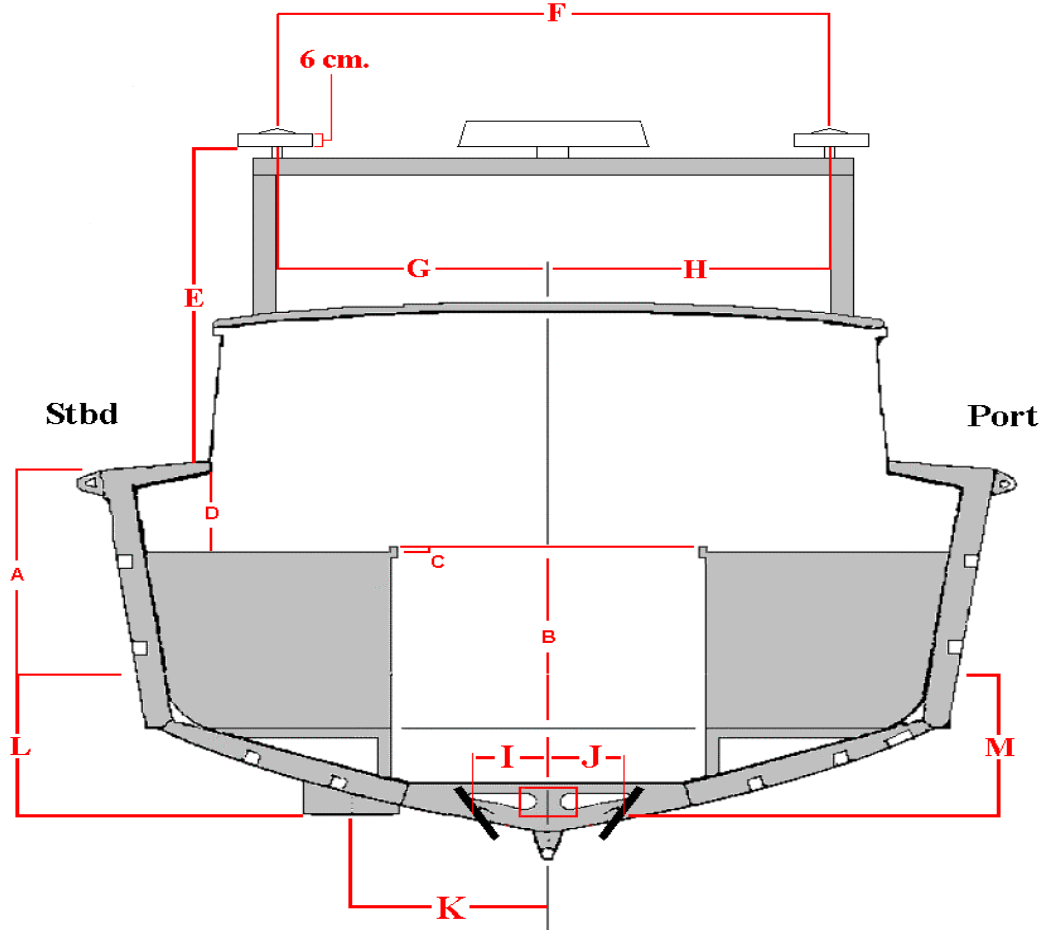

		X (athwartship)		Z (vertical)	
		cm.	date measured	cm.	date measured
Waterline to deck	A	n/a	n/a	100.5	May-00
MRU to counter top rail	B	n/a	n/a	103.6	May-00
Countertop rail	C	n/a	n/a	0.0	May-00
Countertop to deck	D	n/a	n/a	21.4	May-00
Deck to bottom of GPS	E	n/a	n/a	175.6	May-00
Waterline to VBES transducer	L	n/a	n/a	42.0	May-00
Waterline to SWMB transducer	M	n/a	n/a	46.2	May-00
GPS to GPS	F	170.3	May-00	n/a	n/a
Centerline to Stbd GPS	G	85.8	May-00	n/a	n/a
Centerline to Port GPS	H	84.5	May-00	n/a	n/a
Centerline to Stbd SWMB ducer	I	33.8	May-00	n/a	n/a
Centerline to Port SWMB ducer	J	34.4	May-00	n/a	n/a
Centerline to VBES transducer	K	51.8	May-00	n/a	n/a

CARIS configuration is based on a Reference Position (RP)
 The RP has been defined to coincide with the location of the MRU

X athwartship distance [+ starboard]
Y along-ship distance [+ towards bow]
Z vertical distance [+ into water]

X	SWMB-ducer offset (equals average I & J)	+/- 0.34	Swath 1
	MRU to RP (mounted centerline)	0.00	Swath 2
Y	RP to MB-ducer (equals C')	1.56	Navigation
	RP to MRU (equals B')	0.00	Gyro
Z	MB-ducer to RP (equals M-(B+D-C-A))	0.22	Heave
	MRU to RP	0.00	Pitch
	MRU to waterline (equals A-D+C-B)	-0.25	Roll
			Waterline

Vessel Name: 1015_Elac1180
Vessel created: August 24, 2004

Depth Sensor:

Sensor Class: Swath
Time Stamp: 2003-086 00:00

Transducer #1:

Pitch Offset: -1.200
Roll Offset: 0.000
Azimuth Offset: -0.300

DeltaX: 0.340
DeltaY: 1.560
DeltaZ: 0.220

Manufacturer:
Model: Unknown
Serial Number:

Transducer #2:

Pitch Offset: -0.650
Roll Offset: 0.000
Azimuth Offset: 0.100

DeltaX: -0.340
DeltaY: 1.560
DeltaZ: 0.220

Manufacturer:
Model: Unknown
Serial Number:

Navigation Sensor:

Time Stamp: 2003-086 00:00

Comments
Latency 0.030
DeltaX: 0.000
DeltaY: 0.000
DeltaZ: 0.000

Manufacturer: (null)
Model: (null)
Serial Number: (null)

Gyro Sensor:

Time Stamp: 2004-086 00:00

Comments
Latency 0.030

Entry 0) Draft: 0.000 Speed: 0.000

Heave Sensor:

Time Stamp: 2004-086 00:00

Comments
Apply Yes
Latency 0.030
DeltaX: 0.000
DeltaY: 0.000
DeltaZ: 0.000

Manufacturer: (null)
Model: (null)
Serial Number: (null)

Pitch Sensor:

Time Stamp: 2004-086 00:00

Comments
Apply Yes
Latency 0.030
Pitch offset: 0.000

Manufacturer: (null)
Model: (null)
Serial Number: (null)

Roll Sensor:

Time Stamp: 2004-086 00:00

Comments
Apply Yes
Latency 0.030
Roll offset: 0.000

Manufacturer: (null)
Model: (null)
Serial Number: (null)

Draft Sensor:

Time Stamp: 2004-086 00:00

Apply Yes
Comments
Entry 1) Draft: 0.000 Speed: 0.000
Entry 2) Draft: 0.000 Speed: 1.600

Entry 3) Draft: 0.010	Speed: 3.200
Entry 4) Draft: 0.020	Speed: 4.300
Entry 5) Draft: 0.010	Speed: 5.100
Entry 6) Draft: 0.010	Speed: 6.100
Entry 7) Draft: 0.020	Speed: 6.500
Entry 8) Draft: 0.030	Speed: 6.900
Entry 9) Draft: 0.010	Speed: 7.700
Entry 10) Draft: -0.040	Speed: 8.500

Svp Sensor:

Time Stamp: 2004-086 00:00

Comments

Svp #1:

Pitch Offset: 0.000
Roll Offset: 37.800
Azimuth Offset: 0.000

DeltaX: -0.340
DeltaY: 1.560
DeltaZ: 0.220

SVP #2:

Pitch Offset: 0.000
Roll Offset: -37.800
Azimuth Offset: 0.000

DeltaX: 0.340
DeltaY: 1.560
DeltaZ: 0.220

WaterLine:

Time Stamp: 2004-086 00:00

Comments

Apply Yes
WaterLine -0.250
WaterLineStdDev 0.000

Appendix IV

Calibration Reports

- **SWMB QC Reports**
 - **Lead Line**
- **Sound Velocity Profiler**

1021_Reson8101

Quality Control Report for file : C:\Temp\2004Patch\1021\1021_checkline

Elevation Range is : -38.036(m) -7.867(m)

Total number of 3D points used: 163338

Starting Time: 16-MAR-2004 20:33:01.83

Ending Time: 16-MAR-2004 20:40:48.98

Minimum tidal reduction: 0 (mm)

Maximum tidal reduction: 0 (mm)

User#	Total	Max(+)	Max(-)	Mean	Std.	3dm(%)	5dm(%)	1%(%)	1.6%(%)
1	878	1.479	-2.581	-0.021	0.2356	89.6	95.4	71.9	83.9
2	1120	1.444	-1.354	0.014	0.2287	89.6	94.8	74.9	87.3
3	1298	1.197	-1.754	0.024	0.1816	91.7	96.9	78.4	92.7
4	1407	0.937	-1.993	0.019	0.1588	94.1	97.9	83.9	94.2
5	1487	0.968	-0.763	0.014	0.1362	95.8	98.3	84.8	95.6
6	1565	0.948	-0.659	0.012	0.1294	96.4	98.9	84.3	95.3
7	1623	0.871	-0.700	0.013	0.1232	96.2	98.9	84.7	95.0
8	1640	1.098	-0.709	0.015	0.1176	96.5	99.4	84.8	94.0
9	1650	0.659	-0.385	0.016	0.1090	97.8	99.6	85.5	94.4
10	1650	0.631	-0.347	0.021	0.1078	97.9	99.6	85.3	93.6
11	1651	0.659	-0.630	0.024	0.1057	98.2	99.6	86.5	94.4
12	1654	0.610	-0.362	0.026	0.1074	97.9	99.6	86.4	94.4
13	1657	0.532	-0.355	0.023	0.1123	97.6	99.8	85.9	94.3
14	1657	0.478	-0.337	0.025	0.1135	97.6	100.0	86.1	94.0
15	1656	0.477	-0.320	0.027	0.1114	97.8	100.0	85.6	94.2
16	1658	0.527	-0.365	0.029	0.1103	97.5	99.9	86.2	94.7
17	1657	0.467	-0.360	0.031	0.1092	96.9	100.0	85.3	95.0
18	1660	0.465	-0.406	0.031	0.1099	97.1	100.0	85.2	95.2
19	1659	0.513	-0.415	0.032	0.1096	96.9	99.9	86.0	95.5
20	1660	0.460	-0.470	0.032	0.1108	96.4	100.0	85.2	96.0
21	1662	0.459	-0.485	0.032	0.1110	96.8	100.0	84.8	96.3
22	1665	0.431	-0.479	0.034	0.1117	96.9	100.0	84.0	96.1
23	1666	0.442	-0.508	0.033	0.1129	96.9	99.9	83.3	96.6
24	1666	0.375	-0.522	0.032	0.1151	96.7	99.8	83.3	96.9
25	1666	0.399	-0.553	0.031	0.1136	97.4	99.8	83.7	96.8
26	1666	0.394	-0.560	0.031	0.1143	97.5	99.6	83.0	96.6
27	1665	0.379	-0.593	0.031	0.1150	97.4	99.5	82.9	96.4
28	1666	0.363	-0.625	0.029	0.1167	97.0	99.6	82.6	95.9
29	1666	0.388	-0.616	0.027	0.1185	96.7	99.5	82.2	95.4
30	1666	0.546	-0.622	0.026	0.1208	96.7	99.3	81.0	95.6
31	1666	0.592	-0.614	0.027	0.1222	96.4	99.3	80.7	95.6
32	1666	0.629	-0.602	0.028	0.1239	96.5	99.3	80.3	94.8
33	1666	0.629	-0.581	0.027	0.1248	96.3	99.4	80.7	94.9
34	1666	0.480	-0.647	0.025	0.1256	96.4	99.3	80.9	94.9
35	1666	0.519	-0.623	0.026	0.1262	96.5	99.2	79.8	94.7
36	1666	0.598	-0.637	0.027	0.1266	96.5	99.0	79.8	93.6
37	1666	0.595	-0.617	0.027	0.1276	96.3	98.9	80.1	93.8
38	1666	0.542	-0.667	0.028	0.1298	96.2	98.9	78.4	93.5
39	1666	0.565	-0.631	0.030	0.1310	96.2	98.8	77.8	93.1
40	1666	0.586	-0.601	0.029	0.1305	95.9	98.7	78.6	93.2
41	1666	0.610	-0.609	0.030	0.1324	95.7	98.6	78.2	92.7
42	1666	0.620	-0.714	0.032	0.1351	95.6	98.7	77.6	92.5
43	1666	0.593	-0.628	0.031	0.1331	95.7	98.4	78.4	92.6
44	1666	0.649	-0.631	0.033	0.1347	95.4	98.3	77.2	92.6
45	1666	0.667	-0.667	0.033	0.1347	95.5	98.4	77.4	91.8
46	1666	0.644	-0.679	0.032	0.1365	95.2	98.3	77.4	92.1
47	1666	0.628	-0.708	0.034	0.1343	95.2	98.6	77.9	92.0
48	1666	0.631	-0.691	0.035	0.1331	95.4	98.6	78.2	92.1
49	1666	0.635	-0.687	0.036	0.1326	95.4	98.6	77.5	92.3

50	1665	0.608	-0.693	0.037	0.1315	95.3	98.8	77.9	91.8
51	1664	0.605	-0.670	0.039	0.1307	95.4	98.9	77.5	92.1
52	1665	0.599	-0.648	0.039	0.1293	95.4	99.0	78.0	92.4
53	1665	0.602	-0.699	0.039	0.1306	95.7	98.9	78.1	92.6
54	1666	0.588	-0.702	0.039	0.1298	95.2	99.0	78.2	92.5
55	1665	0.585	-0.785	0.038	0.1305	95.6	99.1	78.4	92.8
56	1665	0.565	-0.800	0.037	0.1303	95.4	99.1	78.3	92.4
57	1666	0.577	-0.772	0.037	0.1300	95.3	98.9	78.3	92.7
58	1666	0.564	-0.745	0.038	0.1301	95.5	98.8	78.3	92.4
59	1666	0.600	-0.718	0.037	0.1295	95.7	98.9	78.7	92.5
60	1666	0.646	-0.716	0.037	0.1272	95.4	98.9	79.2	92.7
61	1666	0.643	-0.748	0.036	0.1285	95.8	98.9	79.2	93.2
62	1666	0.630	-0.712	0.035	0.1278	95.9	98.8	80.3	93.4
63	1666	0.667	-0.791	0.034	0.1288	96.3	98.7	79.3	93.2
64	1666	0.601	-0.745	0.033	0.1285	95.7	98.9	81.4	92.9
65	1666	0.612	-0.724	0.033	0.1249	95.7	98.9	82.2	93.6
66	1666	0.649	-0.681	0.032	0.1250	95.8	99.0	82.3	93.7
67	1666	0.579	-0.709	0.031	0.1251	96.0	99.1	80.7	93.9
68	1666	0.557	-0.659	0.030	0.1240	95.4	99.1	80.6	94.2
69	1666	0.538	-0.687	0.029	0.1233	95.7	99.3	80.9	94.1
70	1666	0.480	-0.755	0.029	0.1225	95.7	99.5	81.6	94.2
71	1666	0.484	-0.625	0.028	0.1200	95.7	99.5	80.8	94.1
72	1666	0.447	-0.653	0.028	0.1204	95.6	99.6	81.6	94.4
73	1666	0.453	-0.615	0.028	0.1178	95.9	99.6	83.0	94.9
74	1666	0.422	-0.565	0.030	0.1164	96.0	99.7	83.3	95.0
75	1666	0.410	-0.529	0.029	0.1153	96.0	99.9	83.7	95.3
76	1666	0.429	-0.591	0.027	0.1146	96.2	99.9	84.5	95.7
77	1666	0.424	-0.521	0.026	0.1130	96.6	99.9	84.8	95.9
78	1665	0.430	-0.547	0.025	0.1140	96.3	99.8	85.9	95.7
79	1666	0.430	-0.501	0.025	0.1138	96.3	99.9	86.2	95.4
80	1666	0.451	-0.475	0.023	0.1143	96.2	100.0	87.0	95.6
81	1665	0.445	-0.431	0.021	0.1153	95.9	100.0	86.2	96.0
82	1666	0.446	-0.509	0.016	0.1191	95.7	99.9	86.2	95.7
83	1666	0.463	-0.768	0.012	0.1270	95.1	99.6	85.2	95.5
84	1666	0.453	-0.821	0.009	0.1354	94.5	99.1	85.2	95.0
85	1659	0.474	-0.942	0.007	0.1432	94.2	99.0	85.0	94.5
86	1661	0.478	-1.060	0.001	0.1469	94.2	98.7	85.2	94.8
87	1649	0.476	-1.138	0.002	0.1405	94.6	98.8	85.4	95.0
88	1648	0.457	-1.313	-0.003	0.1593	94.5	98.4	85.3	94.4
89	1645	0.446	-1.346	0.001	0.1497	94.4	98.9	85.7	94.9
90	1640	0.434	-1.378	0.000	0.1505	94.2	99.0	85.3	95.0
91	1631	0.442	-1.405	-0.004	0.1580	94.5	98.7	84.2	95.3
92	1623	0.423	-1.312	-0.012	0.1664	94.0	98.5	83.5	95.2
93	1609	0.443	-1.161	-0.013	0.1532	94.3	98.7	84.6	95.2
94	1596	0.464	-1.133	-0.020	0.1509	94.2	98.4	86.2	94.3
95	1576	0.483	-0.835	-0.026	0.1428	94.4	98.4	84.5	93.3
96	1519	0.528	-1.228	-0.023	0.1389	93.5	98.9	85.4	95.3
97	1474	0.549	-0.857	-0.027	0.1362	93.8	98.6	87.3	95.7
98	1436	1.230	-0.874	-0.022	0.1359	94.4	98.7	87.4	96.2
99	1345	0.699	-1.132	-0.020	0.1283	95.4	98.7	89.1	95.8
100	1181	0.849	-1.164	-0.010	0.1363	96.3	99.0	89.5	96.2
101	950	1.335	-1.616	-0.017	0.1937	91.5	96.3	82.1	91.6

Classification report 1 of 3

IHO statistics a/b are : 0.250 0.008

User#	Total	# fail	% fail	# pass	% pass
=====	=====	=====	=====	=====	=====
1	878	100	11.39	778	88.61
2	1120	124	11.07	996	88.93
3	1298	106	8.17	1192	91.83
4	1407	85	6.04	1322	93.96
5	1487	69	4.64	1418	95.36
6	1565	56	3.58	1509	96.42
7	1623	56	3.45	1567	96.55
8	1640	58	3.54	1582	96.46
9	1650	43	2.61	1607	97.39
10	1650	38	2.30	1612	97.70
11	1651	39	2.36	1612	97.64
12	1654	49	2.96	1605	97.04
13	1657	48	2.90	1609	97.10
14	1657	44	2.66	1613	97.34
15	1656	42	2.54	1614	97.46
16	1658	47	2.83	1611	97.17
17	1657	53	3.20	1604	96.80
18	1660	52	3.13	1608	96.87
19	1659	54	3.25	1605	96.75
20	1660	56	3.37	1604	96.63
21	1662	59	3.55	1603	96.45
22	1665	55	3.30	1610	96.70
23	1666	49	2.94	1617	97.06
24	1666	55	3.30	1611	96.70
25	1666	47	2.82	1619	97.18
26	1666	41	2.46	1625	97.54
27	1665	44	2.64	1621	97.36
28	1666	51	3.06	1615	96.94
29	1666	55	3.30	1611	96.70
30	1666	57	3.42	1609	96.58
31	1666	58	3.48	1608	96.52
32	1666	57	3.42	1609	96.58
33	1666	58	3.48	1608	96.52
34	1666	55	3.30	1611	96.70
35	1666	58	3.48	1608	96.52
36	1666	58	3.48	1608	96.52
37	1666	57	3.42	1609	96.58
38	1666	65	3.90	1601	96.10
39	1666	66	3.96	1600	96.04
40	1666	74	4.44	1592	95.56
41	1666	75	4.50	1591	95.50
42	1666	80	4.80	1586	95.20
43	1666	78	4.68	1588	95.32
44	1666	77	4.62	1589	95.38
45	1666	79	4.74	1587	95.26
46	1666	84	5.04	1582	94.96
47	1666	80	4.80	1586	95.20
48	1666	85	5.10	1581	94.90
49	1666	76	4.56	1590	95.44
50	1665	89	5.35	1576	94.65
51	1664	91	5.47	1573	94.53
52	1665	93	5.59	1572	94.41
53	1665	87	5.23	1578	94.77
54	1666	93	5.58	1573	94.42
55	1665	95	5.71	1570	94.29
56	1665	100	6.01	1565	93.99
57	1666	93	5.58	1573	94.42
58	1666	96	5.76	1570	94.24
59	1666	96	5.76	1570	94.24
60	1666	95	5.70	1571	94.30
61	1666	90	5.40	1576	94.60

62	1666	88	5.28	1578	94.72
63	1666	85	5.10	1581	94.90
64	1666	85	5.10	1581	94.90
65	1666	81	4.86	1585	95.14
66	1666	78	4.68	1588	95.32
67	1666	73	4.38	1593	95.62
68	1666	79	4.74	1587	95.26
69	1666	80	4.80	1586	95.20
70	1666	75	4.50	1591	95.50
71	1666	75	4.50	1591	95.50
72	1666	80	4.80	1586	95.20
73	1666	72	4.32	1594	95.68
74	1666	67	4.02	1599	95.98
75	1666	65	3.90	1601	96.10
76	1666	66	3.96	1600	96.04
77	1666	57	3.42	1609	96.58
78	1665	60	3.60	1605	96.40
79	1666	63	3.78	1603	96.22
80	1666	64	3.84	1602	96.16
81	1665	66	3.96	1599	96.04
82	1666	66	3.96	1600	96.04
83	1666	78	4.68	1588	95.32
84	1666	86	5.16	1580	94.84
85	1659	92	5.55	1567	94.45
86	1661	93	5.60	1568	94.40
87	1649	87	5.28	1562	94.72
88	1648	90	5.46	1558	94.54
89	1645	89	5.41	1556	94.59
90	1640	89	5.43	1551	94.57
91	1631	87	5.33	1544	94.67
92	1623	91	5.61	1532	94.39
93	1609	87	5.41	1522	94.59
94	1596	87	5.45	1509	94.55
95	1576	86	5.46	1490	94.54
96	1519	88	5.79	1431	94.21
97	1474	85	5.77	1389	94.23
98	1436	75	5.22	1361	94.78
99	1345	58	4.31	1287	95.69
100	1181	53	4.49	1128	95.51
101	950	87	9.16	863	90.84

Classification report 2 of 3

IHO statistics a/b are : 0.500 0.013

User#	Total	# fail	% fail	# pass	% pass
=====	=====	=====	=====	=====	=====
1	878	31	3.53	847	96.47
2	1120	46	4.11	1074	95.89
3	1298	26	2.00	1272	98.00
4	1407	20	1.42	1387	98.58
5	1487	19	1.28	1468	98.72
6	1565	13	0.83	1552	99.17
7	1623	9	0.55	1614	99.45
8	1640	5	0.30	1635	99.70
9	1650	3	0.18	1647	99.82
10	1650	4	0.24	1646	99.76
11	1651	2	0.12	1649	99.88
12	1654	1	0.06	1653	99.94
13	1657	0	0.00	1657	100.00
14	1657	0	0.00	1657	100.00
15	1656	0	0.00	1656	100.00
16	1658	0	0.00	1658	100.00
17	1657	0	0.00	1657	100.00
18	1660	0	0.00	1660	100.00
19	1659	0	0.00	1659	100.00
20	1660	0	0.00	1660	100.00
21	1662	0	0.00	1662	100.00
22	1665	0	0.00	1665	100.00
23	1666	0	0.00	1666	100.00
24	1666	0	0.00	1666	100.00
25	1666	0	0.00	1666	100.00
26	1666	0	0.00	1666	100.00
27	1665	0	0.00	1665	100.00
28	1666	0	0.00	1666	100.00
29	1666	0	0.00	1666	100.00
30	1666	1	0.06	1665	99.94
31	1666	1	0.06	1665	99.94
32	1666	1	0.06	1665	99.94
33	1666	1	0.06	1665	99.94
34	1666	0	0.00	1666	100.00
35	1666	0	0.00	1666	100.00
36	1666	1	0.06	1665	99.94
37	1666	1	0.06	1665	99.94
38	1666	1	0.06	1665	99.94
39	1666	0	0.00	1666	100.00
40	1666	3	0.18	1663	99.82
41	1666	1	0.06	1665	99.94
42	1666	6	0.36	1660	99.64
43	1666	3	0.18	1663	99.82
44	1666	5	0.30	1661	99.70
45	1666	6	0.36	1660	99.64
46	1666	10	0.60	1656	99.40
47	1666	9	0.54	1657	99.46
48	1666	6	0.36	1660	99.64
49	1666	7	0.42	1659	99.58
50	1665	6	0.36	1659	99.64
51	1664	6	0.36	1658	99.64
52	1665	3	0.18	1662	99.82
53	1665	5	0.30	1660	99.70
54	1666	7	0.42	1659	99.58
55	1665	7	0.42	1658	99.58
56	1665	6	0.36	1659	99.64
57	1666	8	0.48	1658	99.52
58	1666	7	0.42	1659	99.58
59	1666	10	0.60	1656	99.40
60	1666	7	0.42	1659	99.58
61	1666	12	0.72	1654	99.28

62	1666	11	0.66	1655	99.34
63	1666	12	0.72	1654	99.28
64	1666	12	0.72	1654	99.28
65	1666	10	0.60	1656	99.40
66	1666	8	0.48	1658	99.52
67	1666	7	0.42	1659	99.58
68	1666	4	0.24	1662	99.76
69	1666	4	0.24	1662	99.76
70	1666	2	0.12	1664	99.88
71	1666	0	0.00	1666	100.00
72	1666	1	0.06	1665	99.94
73	1666	0	0.00	1666	100.00
74	1666	0	0.00	1666	100.00
75	1666	0	0.00	1666	100.00
76	1666	0	0.00	1666	100.00
77	1666	0	0.00	1666	100.00
78	1665	0	0.00	1665	100.00
79	1666	0	0.00	1666	100.00
80	1666	0	0.00	1666	100.00
81	1665	0	0.00	1665	100.00
82	1666	0	0.00	1666	100.00
83	1666	4	0.24	1662	99.76
84	1666	9	0.54	1657	99.46
85	1659	11	0.66	1648	99.34
86	1661	13	0.78	1648	99.22
87	1649	12	0.73	1637	99.27
88	1648	18	1.09	1630	98.91
89	1645	9	0.55	1636	99.45
90	1640	12	0.73	1628	99.27
91	1631	16	0.98	1615	99.02
92	1623	22	1.36	1601	98.64
93	1609	19	1.18	1590	98.82
94	1596	17	1.07	1579	98.93
95	1576	11	0.70	1565	99.30
96	1519	5	0.33	1514	99.67
97	1474	10	0.68	1464	99.32
98	1436	8	0.56	1428	99.44
99	1345	8	0.59	1337	99.41
100	1181	9	0.76	1172	99.24
101	950	23	2.42	927	97.58

Classification report 3 of 3

IHO statistics a/b are : 1.000 0.023

User#	Total	# fail	% fail	# pass	% pass
=====	=====	=====	=====	=====	=====
1	878	6	0.68	872	99.32
2	1120	4	0.36	1116	99.64
3	1298	2	0.15	1296	99.85
4	1407	2	0.14	1405	99.86
5	1487	0	0.00	1487	100.00
6	1565	0	0.00	1565	100.00
7	1623	0	0.00	1623	100.00
8	1640	0	0.00	1640	100.00
9	1650	0	0.00	1650	100.00
10	1650	0	0.00	1650	100.00
11	1651	0	0.00	1651	100.00
12	1654	0	0.00	1654	100.00
13	1657	0	0.00	1657	100.00
14	1657	0	0.00	1657	100.00
15	1656	0	0.00	1656	100.00
16	1658	0	0.00	1658	100.00
17	1657	0	0.00	1657	100.00
18	1660	0	0.00	1660	100.00
19	1659	0	0.00	1659	100.00
20	1660	0	0.00	1660	100.00
21	1662	0	0.00	1662	100.00
22	1665	0	0.00	1665	100.00
23	1666	0	0.00	1666	100.00
24	1666	0	0.00	1666	100.00
25	1666	0	0.00	1666	100.00
26	1666	0	0.00	1666	100.00
27	1665	0	0.00	1665	100.00
28	1666	0	0.00	1666	100.00
29	1666	0	0.00	1666	100.00
30	1666	0	0.00	1666	100.00
31	1666	0	0.00	1666	100.00
32	1666	0	0.00	1666	100.00
33	1666	0	0.00	1666	100.00
34	1666	0	0.00	1666	100.00
35	1666	0	0.00	1666	100.00
36	1666	0	0.00	1666	100.00
37	1666	0	0.00	1666	100.00
38	1666	0	0.00	1666	100.00
39	1666	0	0.00	1666	100.00
40	1666	0	0.00	1666	100.00
41	1666	0	0.00	1666	100.00
42	1666	0	0.00	1666	100.00
43	1666	0	0.00	1666	100.00
44	1666	0	0.00	1666	100.00
45	1666	0	0.00	1666	100.00
46	1666	0	0.00	1666	100.00
47	1666	0	0.00	1666	100.00
48	1666	0	0.00	1666	100.00
49	1666	0	0.00	1666	100.00
50	1665	0	0.00	1665	100.00
51	1664	0	0.00	1664	100.00
52	1665	0	0.00	1665	100.00
53	1665	0	0.00	1665	100.00
54	1666	0	0.00	1666	100.00
55	1665	0	0.00	1665	100.00
56	1665	0	0.00	1665	100.00
57	1666	0	0.00	1666	100.00
58	1666	0	0.00	1666	100.00
59	1666	0	0.00	1666	100.00
60	1666	0	0.00	1666	100.00
61	1666	0	0.00	1666	100.00

62	1666	0	0.00	1666	100.00
63	1666	0	0.00	1666	100.00
64	1666	0	0.00	1666	100.00
65	1666	0	0.00	1666	100.00
66	1666	0	0.00	1666	100.00
67	1666	0	0.00	1666	100.00
68	1666	0	0.00	1666	100.00
69	1666	0	0.00	1666	100.00
70	1666	0	0.00	1666	100.00
71	1666	0	0.00	1666	100.00
72	1666	0	0.00	1666	100.00
73	1666	0	0.00	1666	100.00
74	1666	0	0.00	1666	100.00
75	1666	0	0.00	1666	100.00
76	1666	0	0.00	1666	100.00
77	1666	0	0.00	1666	100.00
78	1665	0	0.00	1665	100.00
79	1666	0	0.00	1666	100.00
80	1666	0	0.00	1666	100.00
81	1665	0	0.00	1665	100.00
82	1666	0	0.00	1666	100.00
83	1666	0	0.00	1666	100.00
84	1666	0	0.00	1666	100.00
85	1659	0	0.00	1659	100.00
86	1661	0	0.00	1661	100.00
87	1649	0	0.00	1649	100.00
88	1648	2	0.12	1646	99.88
89	1645	2	0.12	1643	99.88
90	1640	2	0.12	1638	99.88
91	1631	2	0.12	1629	99.88
92	1623	2	0.12	1621	99.88
93	1609	0	0.00	1609	100.00
94	1596	0	0.00	1596	100.00
95	1576	0	0.00	1576	100.00
96	1519	0	0.00	1519	100.00
97	1474	0	0.00	1474	100.00
98	1436	0	0.00	1436	100.00
99	1345	0	0.00	1345	100.00
100	1181	0	0.00	1181	100.00
101	950	3	0.32	947	99.68

1016_Elac1180

Quality Control Report for file : C:\Temp\2004Patch\1016_Elac\1016_checkline

Elevation Range is : -90.223(m) -58.388(m)

Total number of 3D points used: 13466

Starting Time: 16-MAR-2004 22:03:15.98

Ending Time: 16-MAR-2004 22:05:54.97

Minimum tidal reduction: 2359 (mm)

Maximum tidal reduction: 2374 (mm)

User#	Total	Max(+)	Max(-)	Mean	Std.	3dm(%)	5dm(%)	1%(%)	1.6%(%)
14	116	1.630	-3.575	-0.537	0.8767	19.8	35.3	50.0	75.0
15	116	1.872	-2.836	-0.459	0.8498	21.6	35.3	50.0	73.3
16	118	1.191	-3.195	-0.563	0.8155	19.5	37.3	55.1	75.4
17	122	1.797	-2.289	-0.429	0.6744	23.0	41.0	58.2	85.2
18	126	1.461	-1.912	-0.445	0.6662	26.2	40.5	54.0	85.7
19	133	1.446	-1.989	-0.376	0.6749	31.6	50.4	63.9	82.7
20	135	0.962	-1.869	-0.409	0.6299	32.6	50.4	59.3	87.4
21	134	1.462	-1.613	-0.289	0.6102	38.1	53.0	67.9	90.3
22	136	1.457	-1.603	-0.227	0.6230	27.9	53.7	70.6	90.4
23	137	1.695	-1.539	-0.208	0.6677	38.0	54.0	70.1	87.6
24	136	2.132	-1.459	-0.134	0.6372	39.7	61.8	73.5	91.2
25	132	1.388	-1.196	-0.231	0.5055	36.4	57.6	78.8	97.0
26	136	1.950	-1.348	-0.165	0.6074	36.0	59.6	72.1	91.2
27	134	1.771	-1.226	-0.101	0.5747	40.3	66.4	82.1	91.8
28	138	2.155	-1.090	-0.165	0.5607	40.6	63.0	79.7	94.9
29	137	1.949	-1.562	-0.076	0.6135	42.3	66.4	81.0	89.8
30	138	1.887	-0.882	-0.019	0.5381	55.8	71.0	84.8	94.9
31	135	2.081	-1.048	-0.082	0.5688	42.2	65.9	81.5	96.3
32	138	2.195	-0.957	-0.041	0.5409	47.1	71.7	85.5	96.4
33	136	1.759	-1.082	-0.058	0.5372	51.5	69.9	83.1	94.9
34	137	1.708	-1.125	-0.106	0.5161	42.3	70.8	83.9	97.1
35	136	1.340	-0.868	-0.040	0.4614	49.3	77.9	86.0	97.1
36	135	1.187	-1.130	-0.050	0.4954	48.9	68.1	84.4	95.6
37	138	1.360	-0.829	-0.042	0.4641	50.0	74.6	88.4	95.7
38	138	1.506	-0.872	0.075	0.4996	52.2	80.4	84.8	94.2
39	138	1.957	-0.917	0.090	0.5121	58.7	79.7	86.2	94.9
40	137	1.406	-0.852	0.016	0.4514	52.6	78.1	89.8	94.9
41	137	1.320	-0.791	0.059	0.4661	51.1	73.0	84.7	96.4
42	138	1.756	-0.835	0.075	0.4758	56.5	78.3	87.7	95.7
43	137	1.699	-0.636	0.029	0.4206	55.5	83.9	92.7	96.4
44	136	1.586	-1.096	0.082	0.4387	60.3	76.5	86.8	97.1
45	137	1.177	-0.868	0.062	0.3791	64.2	87.6	91.2	97.8
46	138	1.196	-0.811	0.029	0.4059	65.9	84.1	87.0	97.8
47	135	1.332	-1.534	0.088	0.4556	56.3	74.1	88.1	95.6
48	137	1.780	-1.230	0.097	0.4571	52.6	78.8	86.9	96.4
49	136	1.703	-0.788	0.040	0.4295	50.7	80.1	90.4	97.1
50	135	1.423	-1.042	0.000	0.4634	49.6	71.1	86.7	97.8
51	137	1.328	-0.872	0.067	0.4541	50.4	71.5	85.4	98.5
52	135	1.047	-0.960	0.017	0.4218	53.3	76.3	88.9	100.0
53	137	1.265	-0.797	0.054	0.4316	47.4	74.5	89.8	99.3
54	136	1.640	-0.882	0.042	0.4676	47.1	73.5	86.8	97.1
55	137	1.456	-0.890	0.108	0.4753	44.5	67.2	86.1	98.5
56	137	1.597	-0.795	0.167	0.5204	39.4	62.0	83.2	92.7
57	138	1.550	-0.789	0.229	0.5168	40.6	59.4	74.6	94.9
58	138	1.316	-0.976	0.144	0.4892	34.8	69.6	81.9	97.8
59	137	1.436	-1.182	0.140	0.5071	44.5	65.0	78.1	97.1
60	135	1.773	-1.089	0.231	0.5521	43.0	64.4	76.3	92.6
61	134	1.432	-1.120	0.221	0.5531	36.6	55.2	70.9	94.0

62	135	1.680	-0.869	0.229	0.5523	38.5	55.6	70.4	95.6
63	136	1.505	-0.974	0.220	0.5991	33.8	55.9	65.4	93.4
64	136	1.481	-1.434	0.145	0.5930	35.3	58.1	71.3	94.9
65	137	1.169	-1.311	-0.085	0.5661	38.0	58.4	74.5	94.9
66	137	0.963	-1.609	-0.158	0.5993	43.1	59.1	72.3	91.2
67	137	1.357	-1.590	-0.044	0.6571	31.4	53.3	67.2	90.5
68	135	0.962	-1.837	-0.121	0.6534	31.1	53.3	73.3	90.4
69	138	0.844	-1.805	-0.277	0.6100	36.2	58.7	73.2	87.7
70	137	1.153	-1.839	-0.114	0.6154	37.2	56.9	73.7	90.5
71	138	1.086	-1.892	-0.265	0.6268	32.6	55.8	69.6	87.7
72	138	0.866	-2.356	-0.375	0.5776	39.9	59.4	72.5	91.3
73	138	1.245	-1.810	-0.119	0.6036	36.2	57.2	78.3	94.9
74	137	0.826	-1.858	-0.281	0.5877	34.3	58.4	73.0	92.7
75	136	0.708	-2.264	-0.381	0.6102	33.1	52.9	69.9	89.7
76	137	1.310	-2.121	-0.264	0.6310	32.1	55.5	67.9	89.8
77	137	0.836	-2.265	-0.400	0.6518	35.8	51.8	65.0	86.9
78	137	0.614	-2.213	-0.509	0.6340	24.8	51.1	63.5	80.3
79	138	1.018	-2.662	-0.428	0.6823	27.5	47.8	58.7	87.0
80	137	0.738	-2.388	-0.535	0.7060	32.1	48.9	62.0	81.8
81	137	0.830	-2.822	-0.599	0.7191	29.2	42.3	54.7	77.4
82	137	0.881	-2.558	-0.522	0.6857	23.4	46.7	56.9	84.7
83	138	0.884	-2.886	-0.654	0.7213	25.4	42.0	50.7	79.7
84	137	0.857	-3.199	-0.729	0.7592	21.9	34.3	50.4	72.3
85	138	0.969	-2.936	-0.682	0.7901	25.4	35.5	47.1	71.7
86	138	0.717	-2.953	-0.801	0.7985	19.6	34.8	43.5	65.9
87	138	0.923	-2.729	-0.817	0.8006	21.7	30.4	42.0	63.8
88	137	1.137	-2.803	-0.711	0.8528	24.1	39.4	48.9	63.5
89	135	1.008	-2.670	-0.801	0.8357	17.8	34.8	44.4	60.7
90	137	1.314	-2.933	-0.908	0.8637	19.7	31.4	41.6	54.7
91	138	1.049	-3.059	-0.825	0.8781	18.8	36.2	47.8	63.0
92	137	1.135	-3.064	-0.827	0.8646	20.4	30.7	46.0	63.5
93	137	1.003	-2.652	-0.937	0.8254	19.7	30.7	38.7	57.7
94	138	0.946	-2.699	-0.838	0.8460	24.6	36.2	44.9	62.3
95	135	1.046	-2.733	-0.838	0.8448	23.0	32.6	43.0	57.0
96	137	1.323	-2.293	-0.866	0.7303	20.4	29.2	37.2	59.1
97	136	1.232	-2.216	-0.746	0.7619	27.2	36.8	41.9	69.9
98	135	0.968	-2.305	-0.832	0.7469	24.4	31.1	37.0	57.8
99	137	0.912	-2.482	-0.874	0.7306	16.8	29.9	38.0	61.3
100	136	1.078	-2.444	-0.774	0.8109	25.7	33.8	39.0	61.8
101	134	0.899	-2.921	-0.941	0.8451	17.9	32.1	41.0	54.5
102	132	0.721	-2.617	-0.973	0.7985	22.0	31.8	38.6	51.5
103	132	0.955	-2.363	-0.917	0.7921	19.7	34.1	40.9	57.6
104	131	0.869	-3.035	-1.083	0.8548	14.5	29.8	36.6	50.4
105	129	0.852	-2.810	-1.140	0.7949	8.5	20.2	34.1	49.6
106	132	0.713	-2.922	-1.120	0.8486	8.3	24.2	36.4	54.5
107	131	0.965	-3.172	-1.243	0.8558	9.9	16.8	24.4	44.3
108	132	0.872	-3.725	-1.338	0.9345	6.8	13.6	23.5	40.2
109	123	0.550	-4.030	-1.254	0.9754	12.2	21.1	27.6	46.3
110	130	0.613	-4.739	-1.456	1.0518	10.0	13.8	19.2	38.5
111	124	0.691	-5.095	-1.520	1.1166	8.1	14.5	21.0	34.7
112	123	0.574	-4.488	-1.549	1.0317	6.5	13.0	17.9	29.3
113	115	0.422	-5.243	-1.691	1.2173	7.0	15.7	20.0	30.4

Classification report 1 of 3

IHO statistics a/b are : 0.250 0.008

User#	Total	# fail	% fail	# pass	% pass
=====	=====	=====	=====	=====	=====
14	116	73	62.93	43	37.07
15	116	68	58.62	48	41.38
16	118	66	55.93	52	44.07
17	122	64	52.46	58	47.54
18	126	66	52.38	60	47.62
19	133	58	43.61	75	56.39
20	135	64	47.41	71	52.59
21	134	55	41.04	79	58.96
22	136	51	37.50	85	62.50
23	137	54	39.42	83	60.58
24	136	49	36.03	87	63.97
25	132	47	35.61	85	64.39
26	136	49	36.03	87	63.97
27	134	37	27.61	97	72.39
28	138	42	30.43	96	69.57
29	137	42	30.66	95	69.34
30	138	28	20.29	110	79.71
31	135	36	26.67	99	73.33
32	138	31	22.46	107	77.54
33	136	37	27.21	99	72.79
34	137	34	24.82	103	75.18
35	136	25	18.38	111	81.62
36	135	34	25.19	101	74.81
37	138	28	20.29	110	79.71
38	138	25	18.12	113	81.88
39	138	24	17.39	114	82.61
40	137	22	16.06	115	83.94
41	137	30	21.90	107	78.10
42	138	25	18.12	113	81.88
43	137	16	11.68	121	88.32
44	136	27	19.85	109	80.15
45	137	14	10.22	123	89.78
46	138	21	15.22	117	84.78
47	135	26	19.26	109	80.74
48	137	24	17.52	113	82.48
49	136	20	14.71	116	85.29
50	135	30	22.22	105	77.78
51	137	29	21.17	108	78.83
52	135	21	15.56	114	84.44
53	137	25	18.25	112	81.75
54	136	27	19.85	109	80.15
55	137	32	23.36	105	76.64
56	137	36	26.28	101	73.72
57	138	48	34.78	90	65.22
58	138	36	26.09	102	73.91
59	137	39	28.47	98	71.53
60	135	40	29.63	95	70.37
61	134	53	39.55	81	60.45
62	135	53	39.26	82	60.74
63	136	56	41.18	80	58.82
64	136	50	36.76	86	63.24
65	137	45	32.85	92	67.15
66	137	52	37.96	85	62.04
67	137	58	42.34	79	57.66
68	135	53	39.26	82	60.74
69	138	45	32.61	93	67.39
70	137	52	37.96	85	62.04
71	138	54	39.13	84	60.87
72	138	52	37.68	86	62.32
73	138	49	35.51	89	64.49
74	137	48	35.04	89	64.96

75	136	57	41.91	79	58.09
76	137	53	38.69	84	61.31
77	137	59	43.07	78	56.93
78	137	62	45.26	75	54.74
79	138	65	47.10	73	52.90
80	137	65	47.45	72	52.55
81	137	74	54.01	63	45.99
82	137	68	49.64	69	50.36
83	138	74	53.62	64	46.38
84	137	82	59.85	55	40.15
85	138	82	59.42	56	40.58
86	138	85	61.59	53	38.41
87	138	92	66.67	46	33.33
88	137	78	56.93	59	43.07
89	135	85	62.96	50	37.04
90	137	85	62.04	52	37.96
91	138	83	60.14	55	39.86
92	137	85	62.04	52	37.96
93	137	92	67.15	45	32.85
94	138	82	59.42	56	40.58
95	135	81	60.00	54	40.00
96	137	92	67.15	45	32.85
97	136	82	60.29	54	39.71
98	135	90	66.67	45	33.33
99	137	90	65.69	47	34.31
100	136	88	64.71	48	35.29
101	134	88	65.67	46	34.33
102	132	88	66.67	44	33.33
103	132	86	65.15	46	34.85
104	131	88	67.18	43	32.82
105	129	98	75.97	31	24.03
106	132	95	71.97	37	28.03
107	131	100	76.34	31	23.66
108	132	109	82.58	23	17.42
109	123	96	78.05	27	21.95
110	130	111	85.38	19	14.62
111	124	104	83.87	20	16.13
112	123	107	86.99	16	13.01
113	115	95	82.61	20	17.39

Classification report 2 of 3

IHO statistics a/b are : 0.500 0.013

User#	Total	# fail	% fail	# pass	% pass
=====	=====	=====	=====	=====	=====
14	116	34	29.31	82	70.69
15	116	32	27.59	84	72.41
16	118	35	29.66	83	70.34
17	122	24	19.67	98	80.33
18	126	31	24.60	95	75.40
19	133	28	21.05	105	78.95
20	135	24	17.78	111	82.22
21	134	16	11.94	118	88.06
22	136	18	13.24	118	86.76
23	137	22	16.06	115	83.94
24	136	17	12.50	119	87.50
25	132	6	4.55	126	95.45
26	136	13	9.56	123	90.44
27	134	12	8.96	122	91.04
28	138	8	5.80	130	94.20
29	137	14	10.22	123	89.78
30	138	7	5.07	131	94.93
31	135	8	5.93	127	94.07
32	138	5	3.62	133	96.38
33	136	10	7.35	126	92.65
34	137	7	5.11	130	94.89
35	136	4	2.94	132	97.06
36	135	8	5.93	127	94.07
37	138	7	5.07	131	94.93
38	138	10	7.25	128	92.75
39	138	10	7.25	128	92.75
40	137	7	5.11	130	94.89
41	137	5	3.65	132	96.35
42	138	7	5.07	131	94.93
43	137	5	3.65	132	96.35
44	136	6	4.41	130	95.59
45	137	5	3.65	132	96.35
46	138	4	2.90	134	97.10
47	135	6	4.44	129	95.56
48	137	6	4.38	131	95.62
49	136	4	2.94	132	97.06
50	135	5	3.70	130	96.30
51	137	3	2.19	134	97.81
52	135	0	0.00	135	100.00
53	137	2	1.46	135	98.54
54	136	4	2.94	132	97.06
55	137	5	3.65	132	96.35
56	137	10	7.30	127	92.70
57	138	7	5.07	131	94.93
58	138	6	4.35	132	95.65
59	137	5	3.65	132	96.35
60	135	11	8.15	124	91.85
61	134	10	7.46	124	92.54
62	135	7	5.19	128	94.81
63	136	11	8.09	125	91.91
64	136	14	10.29	122	89.71
65	137	12	8.76	125	91.24
66	137	15	10.95	122	89.05
67	137	16	11.68	121	88.32
68	135	16	11.85	119	88.15
69	138	18	13.04	120	86.96
70	137	15	10.95	122	89.05
71	138	20	14.49	118	85.51
72	138	18	13.04	120	86.96
73	138	11	7.97	127	92.03
74	137	14	10.22	123	89.78

75	136	18	13.24	118	86.76
76	137	15	10.95	122	89.05
77	137	22	16.06	115	83.94
78	137	27	19.71	110	80.29
79	138	24	17.39	114	82.61
80	137	30	21.90	107	78.10
81	137	35	25.55	102	74.45
82	137	27	19.71	110	80.29
83	138	37	26.81	101	73.19
84	137	49	35.77	88	64.23
85	138	42	30.43	96	69.57
86	138	55	39.86	83	60.14
87	138	58	42.03	80	57.97
88	137	55	40.15	82	59.85
89	135	56	41.48	79	58.52
90	137	64	46.72	73	53.28
91	138	56	40.58	82	59.42
92	137	56	40.88	81	59.12
93	137	65	47.45	72	52.55
94	138	58	42.03	80	57.97
95	135	59	43.70	76	56.30
96	137	63	45.99	74	54.01
97	136	54	39.71	82	60.29
98	135	64	47.41	71	52.59
99	137	67	48.91	70	51.09
100	136	60	44.12	76	55.88
101	134	69	51.49	65	48.51
102	132	68	51.52	64	48.48
103	132	64	48.48	68	51.52
104	131	70	53.44	61	46.56
105	129	69	53.49	60	46.51
106	132	64	48.48	68	51.52
107	131	78	59.54	53	40.46
108	132	79	59.85	53	40.15
109	123	68	55.28	55	44.72
110	130	81	62.31	49	37.69
111	124	86	69.35	38	30.65
112	123	93	75.61	30	24.39
113	115	84	73.04	31	26.96

Classification report 3 of 3

IHO statistics a/b are : 1.000 0.023

User#	Total	# fail	% fail	# pass	% pass
=====	=====	=====	=====	=====	=====
14	116	3	2.59	113	97.41
15	116	3	2.59	113	97.41
16	118	4	3.39	114	96.61
17	122	1	0.82	121	99.18
18	126	1	0.79	125	99.21
19	133	0	0.00	133	100.00
20	135	1	0.74	134	99.26
21	134	0	0.00	134	100.00
22	136	0	0.00	136	100.00
23	137	0	0.00	137	100.00
24	136	1	0.74	135	99.26
25	132	0	0.00	132	100.00
26	136	1	0.74	135	99.26
27	134	0	0.00	134	100.00
28	138	1	0.72	137	99.28
29	137	1	0.73	136	99.27
30	138	0	0.00	138	100.00
31	135	1	0.74	134	99.26
32	138	2	1.45	136	98.55
33	136	0	0.00	136	100.00
34	137	0	0.00	137	100.00
35	136	0	0.00	136	100.00
36	135	0	0.00	135	100.00
37	138	0	0.00	138	100.00
38	138	0	0.00	138	100.00
39	138	1	0.72	137	99.28
40	137	0	0.00	137	100.00
41	137	0	0.00	137	100.00
42	138	0	0.00	138	100.00
43	137	0	0.00	137	100.00
44	136	0	0.00	136	100.00
45	137	0	0.00	137	100.00
46	138	0	0.00	138	100.00
47	135	0	0.00	135	100.00
48	137	0	0.00	137	100.00
49	136	0	0.00	136	100.00
50	135	0	0.00	135	100.00
51	137	0	0.00	137	100.00
52	135	0	0.00	135	100.00
53	137	0	0.00	137	100.00
54	136	0	0.00	136	100.00
55	137	0	0.00	137	100.00
56	137	0	0.00	137	100.00
57	138	0	0.00	138	100.00
58	138	0	0.00	138	100.00
59	137	0	0.00	137	100.00
60	135	0	0.00	135	100.00
61	134	0	0.00	134	100.00
62	135	0	0.00	135	100.00
63	136	0	0.00	136	100.00
64	136	0	0.00	136	100.00
65	137	0	0.00	137	100.00
66	137	0	0.00	137	100.00
67	137	0	0.00	137	100.00
68	135	0	0.00	135	100.00
69	138	0	0.00	138	100.00
70	137	1	0.73	136	99.27
71	138	1	0.72	137	99.28
72	138	3	2.17	135	97.83
73	138	0	0.00	138	100.00
74	137	0	0.00	137	100.00

75	136	3	2.21	133	97.79
76	137	2	1.46	135	98.54
77	137	4	2.92	133	97.08
78	137	5	3.65	132	96.35
79	138	5	3.62	133	96.38
80	137	7	5.11	130	94.89
81	137	6	4.38	131	95.62
82	137	5	3.65	132	96.35
83	138	8	5.80	130	94.20
84	137	8	5.84	129	94.16
85	138	10	7.25	128	92.75
86	138	10	7.25	128	92.75
87	138	13	9.42	125	90.58
88	137	12	8.76	125	91.24
89	135	13	9.63	122	90.37
90	137	17	12.41	120	87.59
91	138	14	10.14	124	89.86
92	137	16	11.68	121	88.32
93	137	19	13.87	118	86.13
94	138	12	8.70	126	91.30
95	135	17	12.59	118	87.41
96	137	7	5.11	130	94.89
97	136	7	5.15	129	94.85
98	135	8	5.93	127	94.07
99	137	8	5.84	129	94.16
100	136	11	8.09	125	91.91
101	134	13	9.70	121	90.30
102	132	17	12.88	115	87.12
103	132	14	10.61	118	89.39
104	131	23	17.56	108	82.44
105	129	23	17.83	106	82.17
106	132	29	21.97	103	78.03
107	131	33	25.19	98	74.81
108	132	36	27.27	96	72.73
109	123	28	22.76	95	77.24
110	130	35	26.92	95	73.08
111	124	33	26.61	91	73.39
112	123	36	29.27	87	70.73
113	115	43	37.39	72	62.61

1006_Reson8101

Quality Control Report for file : C:\Temp\2004Patch\1006\1006_checkline

Elevation Range is : -37.666(m) -8.057(m)

Total number of 3D points used: 500141

Starting Time: 17-MAR-2004 22:03:38.88

Ending Time: 17-MAR-2004 22:19:00.45

Minimum tidal reduction: 0 (mm)

Maximum tidal reduction: 0 (mm)

User#	Total	Max(+)	Max(-)	Mean	Std.	3dm(%)	5dm(%)	1%(%)	1.6%(%)
1	3572	1.828	-1.649	-0.066	0.2629	80.8	93.0	49.8	75.1
2	4243	1.152	-1.402	-0.036	0.2333	85.6	94.2	65.3	83.1
3	4521	1.135	-1.522	-0.014	0.2409	85.6	94.0	70.9	84.7
4	4651	1.024	-1.567	-0.001	0.2265	87.0	94.6	74.2	86.3
5	4731	0.970	-1.330	0.012	0.1988	88.8	96.2	75.6	87.8
6	4875	0.992	-1.053	0.023	0.1896	89.4	96.3	76.2	88.1
7	4977	1.069	-1.956	0.037	0.1956	89.5	96.0	75.4	87.4
8	5044	1.138	-0.956	0.045	0.1929	90.1	96.1	76.1	88.0
9	5036	1.183	-0.956	0.049	0.1888	90.7	96.4	76.3	88.1
10	5033	1.238	-1.477	0.057	0.1891	91.3	96.5	76.1	88.2
11	5037	1.260	-0.970	0.067	0.1847	91.7	96.5	75.8	87.9
12	5042	1.253	-1.735	0.075	0.1859	91.6	96.3	73.6	87.3
13	5044	1.256	-0.654	0.084	0.1812	91.7	96.4	72.1	86.9
14	5049	1.269	-0.608	0.087	0.1815	91.8	96.3	71.7	86.1
15	5053	1.275	-0.652	0.093	0.1809	91.8	96.2	71.3	85.6
16	5057	1.292	-0.676	0.097	0.1812	91.5	96.2	70.5	85.4
17	5061	1.302	-0.518	0.101	0.1809	91.3	96.3	69.1	85.1
18	5056	1.302	-0.447	0.101	0.1779	91.2	96.5	69.0	85.1
19	5047	1.294	-0.496	0.100	0.1746	91.1	96.6	69.1	85.1
20	5039	1.263	-0.471	0.098	0.1712	91.2	96.8	69.2	85.6
21	5033	1.252	-0.482	0.096	0.1702	91.1	96.9	69.1	85.9
22	5034	1.290	-0.543	0.099	0.1724	90.9	96.9	68.4	85.3
23	5034	1.313	-0.515	0.099	0.1753	90.8	96.7	68.6	84.9
24	5033	1.337	-0.554	0.097	0.1778	91.0	96.6	68.7	85.0
25	5034	1.339	-0.582	0.095	0.1799	90.8	96.7	68.5	85.1
26	5036	1.383	-0.520	0.095	0.1817	90.6	96.6	68.5	85.1
27	5038	1.366	-0.511	0.098	0.1831	90.3	96.6	67.5	84.7
28	5041	1.375	-0.517	0.097	0.1847	90.3	96.7	67.7	84.6
29	5043	1.388	-0.539	0.098	0.1853	89.9	96.5	67.3	84.3
30	5045	1.392	-0.576	0.098	0.1852	89.7	96.4	67.3	84.1
31	5045	1.375	-0.598	0.098	0.1855	89.5	96.2	67.8	83.4
32	5042	1.383	-0.602	0.100	0.1865	89.4	96.2	67.1	83.6
33	5043	1.378	-0.638	0.101	0.1861	89.3	96.3	67.6	83.0
34	5047	1.382	-0.585	0.102	0.1856	89.5	96.4	67.3	83.0
35	5051	1.401	-0.630	0.101	0.1861	89.5	96.4	67.2	82.7
36	5052	1.388	-0.610	0.100	0.1855	89.6	96.2	67.8	82.9
37	5054	1.367	-0.621	0.101	0.1856	89.9	96.2	67.5	82.4
38	5053	1.375	-0.671	0.101	0.1836	89.9	96.2	67.2	82.6
39	5053	1.332	-0.699	0.100	0.1832	89.8	96.3	67.1	82.7
40	5052	1.307	-0.570	0.101	0.1813	89.9	96.3	67.0	82.4
41	5050	1.300	-0.581	0.100	0.1809	89.4	96.1	66.7	82.0
42	5050	1.273	-0.581	0.100	0.1791	89.7	96.2	67.2	82.5
43	5049	1.275	-0.652	0.100	0.1787	89.4	96.1	66.8	82.3
44	5048	1.237	-0.642	0.099	0.1784	89.2	96.2	67.0	82.1
45	5048	1.228	-0.645	0.098	0.1786	89.3	96.1	66.6	82.0
46	5041	1.191	-0.647	0.098	0.1778	89.4	96.1	67.2	82.2
47	5012	1.171	-0.681	0.098	0.1782	89.2	95.9	66.5	82.2
48	4978	1.180	-0.720	0.099	0.1784	89.1	95.9	66.5	81.7
49	4986	1.180	-0.732	0.101	0.1804	88.9	95.7	66.1	81.3

50	5006	1.188	-0.709	0.102	0.1804	88.9	95.6	66.2	81.1
51	5040	1.186	-0.767	0.102	0.1824	88.8	95.5	65.9	81.3
52	5051	1.191	-0.795	0.102	0.1830	88.6	95.3	66.3	81.3
53	5054	1.199	-0.817	0.101	0.1838	88.7	95.5	66.3	81.5
54	5055	1.182	-0.860	0.100	0.1840	88.8	95.5	66.4	81.5
55	5056	1.176	-0.831	0.100	0.1849	88.9	95.4	66.3	81.4
56	5057	1.214	-0.862	0.100	0.1856	88.7	95.4	66.4	81.7
57	5058	1.231	-0.897	0.101	0.1859	88.6	95.4	66.6	81.1
58	5059	1.221	-0.901	0.100	0.1860	88.7	95.6	66.3	81.3
59	5059	1.248	-0.834	0.101	0.1858	89.1	95.5	66.3	81.4
60	5061	1.244	-0.857	0.101	0.1842	89.1	95.5	66.5	81.7
61	5062	1.229	-0.852	0.102	0.1845	89.1	95.6	66.3	81.6
62	5062	1.228	-0.824	0.102	0.1840	89.3	95.7	65.7	81.4
63	5061	1.239	-0.861	0.103	0.1838	89.0	95.6	66.6	81.4
64	5060	1.246	-0.814	0.104	0.1832	89.2	95.7	65.9	82.2
65	5063	1.260	-0.780	0.104	0.1821	89.5	95.7	66.2	81.7
66	5062	1.252	-0.807	0.104	0.1816	89.5	96.0	66.0	82.4
67	5060	1.258	-0.807	0.103	0.1807	89.5	96.0	66.0	82.1
68	5057	1.268	-0.727	0.102	0.1775	90.4	96.1	65.9	82.7
69	5051	1.225	-0.694	0.101	0.1726	90.5	96.3	66.2	83.5
70	5046	1.218	-0.693	0.100	0.1695	90.8	96.6	66.5	83.6
71	5043	1.174	-0.634	0.097	0.1664	91.1	96.6	67.0	84.2
72	5041	1.140	-0.566	0.095	0.1646	91.7	96.7	67.0	84.8
73	5039	1.141	-0.546	0.097	0.1628	91.8	96.8	66.6	84.8
74	5038	1.097	-0.561	0.095	0.1607	91.9	96.8	66.8	85.5
75	5037	1.029	-0.526	0.097	0.1571	92.0	97.0	66.6	85.8
76	5035	0.980	-0.487	0.094	0.1552	92.2	97.0	68.5	86.3
77	5036	0.929	-0.517	0.092	0.1545	92.4	97.0	69.2	86.7
78	5039	0.984	-0.565	0.092	0.1562	92.4	96.8	69.5	86.7
79	5043	1.022	-0.568	0.090	0.1584	92.5	96.7	69.9	86.7
80	5045	1.030	-0.577	0.089	0.1599	92.4	96.7	70.2	86.7
81	5048	1.054	-0.626	0.086	0.1635	92.3	96.6	70.7	86.9
82	5053	1.101	-0.651	0.083	0.1669	92.2	96.6	70.9	87.1
83	5053	1.132	-0.650	0.086	0.1694	91.7	96.5	70.0	86.6
84	5055	1.164	-0.630	0.086	0.1717	91.5	96.5	70.1	86.4
85	5054	1.215	-0.877	0.084	0.1740	91.6	96.5	70.2	86.3
86	5050	1.222	-0.764	0.084	0.1745	91.3	96.6	70.4	86.3
87	5045	1.256	-0.610	0.081	0.1753	91.0	96.7	71.6	86.6
88	5040	1.289	-0.506	0.080	0.1772	90.6	96.8	71.8	86.7
89	5051	1.308	-0.620	0.080	0.1803	90.8	96.4	72.4	87.0
90	5054	1.304	-0.762	0.074	0.1836	90.6	96.2	73.4	86.9
91	5055	1.297	-0.577	0.070	0.1860	90.1	96.1	73.6	87.1
92	5057	1.274	-1.533	0.060	0.1912	89.8	95.9	75.5	87.3
93	5058	1.292	-0.978	0.052	0.1932	89.9	95.8	76.8	87.4
94	4961	1.280	-0.891	0.042	0.1969	90.0	95.4	77.0	87.2
95	4883	1.068	-0.949	0.025	0.1887	90.6	95.9	77.8	88.3
96	4792	1.141	-1.614	0.006	0.2101	89.6	95.1	75.6	87.9
97	4692	1.164	-1.800	-0.014	0.2331	88.7	94.5	73.4	87.0
98	4502	1.091	-2.154	-0.042	0.2519	86.8	93.7	68.8	85.9
99	4266	0.976	-1.821	-0.074	0.2644	83.2	92.2	61.5	81.1
100	3795	1.018	-1.833	-0.113	0.2902	79.8	89.9	48.7	74.1
101	2748	1.076	-1.803	-0.125	0.3052	77.0	90.2	39.3	67.2

Classification report 1 of 3

IHO statistics a/b are : 0.250 0.008

User#	Total	# fail	% fail	# pass	% pass
=====	=====	=====	=====	=====	=====
1	3572	765	21.42	2807	78.58
2	4243	654	15.41	3589	84.59
3	4521	651	14.40	3870	85.60
4	4651	598	12.86	4053	87.14
5	4731	546	11.54	4185	88.46
6	4875	531	10.89	4344	89.11
7	4977	551	11.07	4426	88.93
8	5044	529	10.49	4515	89.51
9	5036	491	9.75	4545	90.25
10	5033	464	9.22	4569	90.78
11	5037	434	8.62	4603	91.38
12	5042	448	8.89	4594	91.11
13	5044	456	9.04	4588	90.96
14	5049	465	9.21	4584	90.79
15	5053	463	9.16	4590	90.84
16	5057	489	9.67	4568	90.33
17	5061	501	9.90	4560	90.10
18	5056	503	9.95	4553	90.05
19	5047	495	9.81	4552	90.19
20	5039	488	9.68	4551	90.32
21	5033	503	9.99	4530	90.01
22	5034	520	10.33	4514	89.67
23	5034	526	10.45	4508	89.55
24	5033	509	10.11	4524	89.89
25	5034	510	10.13	4524	89.87
26	5036	519	10.31	4517	89.69
27	5038	527	10.46	4511	89.54
28	5041	540	10.71	4501	89.29
29	5043	563	11.16	4480	88.84
30	5045	591	11.71	4454	88.29
31	5045	589	11.67	4456	88.33
32	5042	595	11.80	4447	88.20
33	5043	595	11.80	4448	88.20
34	5047	601	11.91	4446	88.09
35	5051	594	11.76	4457	88.24
36	5052	586	11.60	4466	88.40
37	5054	570	11.28	4484	88.72
38	5053	573	11.34	4480	88.66
39	5053	570	11.28	4483	88.72
40	5052	567	11.22	4485	88.78
41	5050	580	11.49	4470	88.51
42	5050	586	11.60	4464	88.40
43	5049	595	11.78	4454	88.22
44	5048	593	11.75	4455	88.25
45	5048	596	11.81	4452	88.19
46	5041	589	11.68	4452	88.32
47	5012	586	11.69	4426	88.31
48	4978	589	11.83	4389	88.17
49	4986	596	11.95	4390	88.05
50	5006	597	11.93	4409	88.07
51	5040	603	11.96	4437	88.04
52	5051	615	12.18	4436	87.82
53	5054	595	11.77	4459	88.23
54	5055	609	12.05	4446	87.95
55	5056	601	11.89	4455	88.11
56	5057	595	11.77	4462	88.23
57	5058	607	12.00	4451	88.00
58	5059	598	11.82	4461	88.18
59	5059	590	11.66	4469	88.34
60	5061	587	11.60	4474	88.40
61	5062	594	11.73	4468	88.27

62	5062	585	11.56	4477	88.44
63	5061	595	11.76	4466	88.24
64	5060	591	11.68	4469	88.32
65	5063	591	11.67	4472	88.33
66	5062	587	11.60	4475	88.40
67	5060	585	11.56	4475	88.44
68	5057	555	10.97	4502	89.03
69	5051	540	10.69	4511	89.31
70	5046	523	10.36	4523	89.64
71	5043	506	10.03	4537	89.97
72	5041	482	9.56	4559	90.44
73	5039	482	9.57	4557	90.43
74	5038	452	8.97	4586	91.03
75	5037	452	8.97	4585	91.03
76	5035	430	8.54	4605	91.46
77	5036	429	8.52	4607	91.48
78	5039	427	8.47	4612	91.53
79	5043	427	8.47	4616	91.53
80	5045	425	8.42	4620	91.58
81	5048	436	8.64	4612	91.36
82	5053	443	8.77	4610	91.23
83	5053	466	9.22	4587	90.78
84	5055	470	9.30	4585	90.70
85	5054	465	9.20	4589	90.80
86	5050	473	9.37	4577	90.63
87	5045	480	9.51	4565	90.49
88	5040	488	9.68	4552	90.32
89	5051	497	9.84	4554	90.16
90	5054	510	10.09	4544	89.91
91	5055	524	10.37	4531	89.63
92	5057	541	10.70	4516	89.30
93	5058	544	10.76	4514	89.24
94	4961	522	10.52	4439	89.48
95	4883	470	9.63	4413	90.37
96	4792	509	10.62	4283	89.38
97	4692	563	12.00	4129	88.00
98	4502	615	13.66	3887	86.34
99	4266	741	17.37	3525	82.63
100	3795	832	21.92	2963	78.08
101	2748	705	25.66	2043	74.34

Classification report 2 of 3

IHO statistics a/b are : 0.500 0.013

User#	Total	# fail	% fail	# pass	% pass
=====	=====	=====	=====	=====	=====
1	3572	196	5.49	3376	94.51
2	4243	182	4.29	4061	95.71
3	4521	211	4.67	4310	95.33
4	4651	192	4.13	4459	95.87
5	4731	148	3.13	4583	96.87
6	4875	142	2.91	4733	97.09
7	4977	161	3.23	4816	96.77
8	5044	170	3.37	4874	96.63
9	5036	161	3.20	4875	96.80
10	5033	161	3.20	4872	96.80
11	5037	167	3.32	4870	96.68
12	5042	175	3.47	4867	96.53
13	5044	163	3.23	4881	96.77
14	5049	167	3.31	4882	96.69
15	5053	173	3.42	4880	96.58
16	5057	170	3.36	4887	96.64
17	5061	176	3.48	4885	96.52
18	5056	171	3.38	4885	96.62
19	5047	159	3.15	4888	96.85
20	5039	151	3.00	4888	97.00
21	5033	142	2.82	4891	97.18
22	5034	144	2.86	4890	97.14
23	5034	145	2.88	4889	97.12
24	5033	141	2.80	4892	97.20
25	5034	142	2.82	4892	97.18
26	5036	146	2.90	4890	97.10
27	5038	149	2.96	4889	97.04
28	5041	154	3.05	4887	96.95
29	5043	154	3.05	4889	96.95
30	5045	152	3.01	4893	96.99
31	5045	157	3.11	4888	96.89
32	5042	157	3.11	4885	96.89
33	5043	161	3.19	4882	96.81
34	5047	157	3.11	4890	96.89
35	5051	160	3.17	4891	96.83
36	5052	164	3.25	4888	96.75
37	5054	157	3.11	4897	96.89
38	5053	161	3.19	4892	96.81
39	5053	157	3.11	4896	96.89
40	5052	158	3.13	4894	96.87
41	5050	163	3.23	4887	96.77
42	5050	152	3.01	4898	96.99
43	5049	157	3.11	4892	96.89
44	5048	150	2.97	4898	97.03
45	5048	153	3.03	4895	96.97
46	5041	150	2.98	4891	97.02
47	5012	160	3.19	4852	96.81
48	4978	158	3.17	4820	96.83
49	4986	170	3.41	4816	96.59
50	5006	169	3.38	4837	96.62
51	5040	170	3.37	4870	96.63
52	5051	180	3.56	4871	96.44
53	5054	183	3.62	4871	96.38
54	5055	181	3.58	4874	96.42
55	5056	190	3.76	4866	96.24
56	5057	189	3.74	4868	96.26
57	5058	192	3.80	4866	96.20
58	5059	190	3.76	4869	96.24
59	5059	193	3.81	4866	96.19
60	5061	193	3.81	4868	96.19
61	5062	189	3.73	4873	96.27

62	5062	190	3.75	4872	96.25
63	5061	193	3.81	4868	96.19
64	5060	186	3.68	4874	96.32
65	5063	189	3.73	4874	96.27
66	5062	176	3.48	4886	96.52
67	5060	176	3.48	4884	96.52
68	5057	170	3.36	4887	96.64
69	5051	162	3.21	4889	96.79
70	5046	149	2.95	4897	97.05
71	5043	144	2.86	4899	97.14
72	5041	142	2.82	4899	97.18
73	5039	146	2.90	4893	97.10
74	5038	142	2.82	4896	97.18
75	5037	140	2.78	4897	97.22
76	5035	141	2.80	4894	97.20
77	5036	140	2.78	4896	97.22
78	5039	142	2.82	4897	97.18
79	5043	144	2.86	4899	97.14
80	5045	152	3.01	4893	96.99
81	5048	153	3.03	4895	96.97
82	5053	157	3.11	4896	96.89
83	5053	157	3.11	4896	96.89
84	5055	160	3.17	4895	96.83
85	5054	162	3.21	4892	96.79
86	5050	159	3.15	4891	96.85
87	5045	149	2.95	4896	97.05
88	5040	150	2.98	4890	97.02
89	5051	161	3.19	4890	96.81
90	5054	172	3.40	4882	96.60
91	5055	177	3.50	4878	96.50
92	5057	185	3.66	4872	96.34
93	5058	191	3.78	4867	96.22
94	4961	193	3.89	4768	96.11
95	4883	160	3.28	4723	96.72
96	4792	187	3.90	4605	96.10
97	4692	210	4.48	4482	95.52
98	4502	218	4.84	4284	95.16
99	4266	254	5.95	4012	94.05
100	3795	293	7.72	3502	92.28
101	2748	232	8.44	2516	91.56

Classification report 3 of 3

IHO statistics a/b are : 1.000 0.023

User#	Total	# fail	% fail	# pass	% pass
=====	=====	=====	=====	=====	=====
1	3572	6	0.17	3566	99.83
2	4243	9	0.21	4234	99.79
3	4521	19	0.42	4502	99.58
4	4651	7	0.15	4644	99.85
5	4731	2	0.04	4729	99.96
6	4875	0	0.00	4875	100.00
7	4977	10	0.20	4967	99.80
8	5044	18	0.36	5026	99.64
9	5036	24	0.48	5012	99.52
10	5033	33	0.66	5000	99.34
11	5037	33	0.66	5004	99.34
12	5042	35	0.69	5007	99.31
13	5044	34	0.67	5010	99.33
14	5049	36	0.71	5013	99.29
15	5053	35	0.69	5018	99.31
16	5057	36	0.71	5021	99.29
17	5061	35	0.69	5026	99.31
18	5056	31	0.61	5025	99.39
19	5047	27	0.53	5020	99.47
20	5039	23	0.46	5016	99.54
21	5033	20	0.40	5013	99.60
22	5034	22	0.44	5012	99.56
23	5034	24	0.48	5010	99.52
24	5033	26	0.52	5007	99.48
25	5034	26	0.52	5008	99.48
26	5036	28	0.56	5008	99.44
27	5038	29	0.58	5009	99.42
28	5041	31	0.61	5010	99.39
29	5043	33	0.65	5010	99.35
30	5045	31	0.61	5014	99.39
31	5045	28	0.56	5017	99.44
32	5042	32	0.63	5010	99.37
33	5043	30	0.59	5013	99.41
34	5047	30	0.59	5017	99.41
35	5051	29	0.57	5022	99.43
36	5052	31	0.61	5021	99.39
37	5054	29	0.57	5025	99.43
38	5053	28	0.55	5025	99.45
39	5053	27	0.53	5026	99.47
40	5052	25	0.49	5027	99.51
41	5050	22	0.44	5028	99.56
42	5050	21	0.42	5029	99.58
43	5049	18	0.36	5031	99.64
44	5048	16	0.32	5032	99.68
45	5048	14	0.28	5034	99.72
46	5041	13	0.26	5028	99.74
47	5012	10	0.20	5002	99.80
48	4978	8	0.16	4970	99.84
49	4986	10	0.20	4976	99.80
50	5006	9	0.18	4997	99.82
51	5040	11	0.22	5029	99.78
52	5051	11	0.22	5040	99.78
53	5054	12	0.24	5042	99.76
54	5055	11	0.22	5044	99.78
55	5056	12	0.24	5044	99.76
56	5057	13	0.26	5044	99.74
57	5058	14	0.28	5044	99.72
58	5059	14	0.28	5045	99.72
59	5059	15	0.30	5044	99.70
60	5061	15	0.30	5046	99.70
61	5062	17	0.34	5045	99.66

62	5062	17	0.34	5045	99.66
63	5061	19	0.38	5042	99.62
64	5060	20	0.40	5040	99.60
65	5063	22	0.43	5041	99.57
66	5062	23	0.45	5039	99.55
67	5060	21	0.42	5039	99.58
68	5057	21	0.42	5036	99.58
69	5051	16	0.32	5035	99.68
70	5046	15	0.30	5031	99.70
71	5043	13	0.26	5030	99.74
72	5041	11	0.22	5030	99.78
73	5039	9	0.18	5030	99.82
74	5038	5	0.10	5033	99.90
75	5037	1	0.02	5036	99.98
76	5035	0	0.00	5035	100.00
77	5036	0	0.00	5036	100.00
78	5039	0	0.00	5039	100.00
79	5043	0	0.00	5043	100.00
80	5045	1	0.02	5044	99.98
81	5048	3	0.06	5045	99.94
82	5053	3	0.06	5050	99.94
83	5053	5	0.10	5048	99.90
84	5055	8	0.16	5047	99.84
85	5054	9	0.18	5045	99.82
86	5050	10	0.20	5040	99.80
87	5045	13	0.26	5032	99.74
88	5040	14	0.28	5026	99.72
89	5051	17	0.34	5034	99.66
90	5054	16	0.32	5038	99.68
91	5055	16	0.32	5039	99.68
92	5057	16	0.32	5041	99.68
93	5058	14	0.28	5044	99.72
94	4961	13	0.26	4948	99.74
95	4883	3	0.06	4880	99.94
96	4792	8	0.17	4784	99.83
97	4692	23	0.49	4669	99.51
98	4502	26	0.58	4476	99.42
99	4266	16	0.38	4250	99.62
100	3795	25	0.66	3770	99.34
101	2748	25	0.91	2723	99.09

1015_Elac1180

Quality Control Report for file :
 C:\Temp\2004Patch\1015_Elac\1015_elac_checkline

Elevation Range is : -105.237(m) -49.416(m)

Total number of 3D points used: 9592

Starting Time: 26-MAR-2004 19:40:35.81
 Ending Time: 26-MAR-2004 19:42:16.87

Minimum tidal reduction: 0 (mm)
 Maximum tidal reduction: 0 (mm)

User#	Total	Max(+)	Max(-)	Mean	Std.	3dm(%)	5dm(%)	1%(%)	1.6%(%)
10	89	1.656	-2.772	-0.346	0.7184	31.5	55.1	70.8	89.9
11	89	1.143	-1.720	-0.617	0.5918	21.3	37.1	47.2	82.0
12	89	1.123	-2.384	-0.638	0.6138	25.8	34.8	53.9	85.4
13	88	1.245	-2.585	-0.532	0.6371	34.1	46.6	69.3	87.5
14	88	1.596	-2.220	-0.772	0.6620	18.2	36.4	44.3	80.7
15	87	1.122	-2.983	-0.874	0.6451	10.3	28.7	43.7	77.0
16	89	0.076	-2.560	-0.995	0.5855	9.0	25.8	34.8	64.0
17	89	0.365	-2.575	-1.090	0.6703	9.0	23.6	27.0	53.9
18	89	0.848	-2.762	-1.018	0.7540	9.0	24.7	36.0	59.6
19	89	2.713	-2.708	-0.841	0.8153	20.2	32.6	48.3	59.6
20	89	0.222	-3.249	-1.278	0.7741	7.9	14.6	25.8	46.1
21	89	0.438	-3.448	-1.231	0.8148	6.7	20.2	28.1	50.6
22	89	0.892	-3.294	-0.711	0.8674	22.5	32.6	46.1	74.2
23	89	0.516	-3.775	-1.570	0.9594	3.4	6.7	13.5	31.5
24	89	1.316	-4.953	-1.666	1.0837	2.2	6.7	12.4	29.2
25	88	1.657	-3.788	-1.015	1.0884	15.9	23.9	31.8	52.3
26	88	0.606	-5.128	-2.100	1.1716	4.5	4.5	5.7	20.5
27	88	1.041	-4.251	-1.798	0.8900	0.0	3.4	4.5	15.9
28	86	0.709	-7.333	-1.673	1.5306	7.0	11.6	19.8	45.3
29	89	2.106	-4.664	-1.718	1.1052	3.4	3.4	6.7	18.0
30	89	2.382	-3.721	-1.089	0.9625	4.5	12.4	20.2	53.9
31	89	1.218	-4.007	-1.249	0.9988	10.1	20.2	25.8	51.7
32	89	1.103	-2.623	-0.638	0.7330	24.7	30.3	42.7	79.8
33	89	2.059	-2.866	-0.492	0.8754	24.7	36.0	48.3	78.7
34	89	0.633	-2.627	-0.635	0.8300	28.1	47.2	62.9	77.5
35	89	1.070	-2.124	-0.497	0.6776	30.3	50.6	61.8	85.4
36	89	0.532	-2.618	-1.160	0.7384	4.5	11.2	18.0	44.9
37	89	0.774	-2.479	-0.601	0.6467	24.7	48.3	66.3	84.3
38	89	0.654	-2.533	-0.768	0.6864	21.3	36.0	46.1	71.9
39	89	0.632	-3.960	-1.101	0.8394	13.5	19.1	28.1	48.3
40	89	0.108	-2.786	-0.971	0.6536	11.2	23.6	36.0	70.8
41	89	0.568	-2.631	-1.000	0.6951	9.0	24.7	33.7	62.9
42	89	0.432	-2.663	-0.953	0.6597	9.0	30.3	40.4	67.4
43	89	0.108	-2.723	-0.989	0.6701	10.1	29.2	37.1	68.5
44	89	0.415	-2.613	-0.888	0.6231	16.9	27.0	38.2	74.2
45	89	0.289	-2.893	-0.863	0.6632	18.0	33.7	46.1	71.9
46	89	0.338	-3.107	-1.025	0.6743	10.1	23.6	25.8	69.7
47	89	0.794	-3.355	-1.039	0.7727	10.1	24.7	29.2	65.2
48	89	0.163	-4.616	-1.033	0.8069	10.1	24.7	33.7	64.0
49	89	0.457	-3.373	-1.099	0.8085	11.2	20.2	29.2	65.2
50	89	0.000	-3.167	-1.189	0.7875	6.7	18.0	23.6	56.2
51	89	0.096	-3.176	-1.193	0.7846	10.1	15.7	23.6	50.6
52	89	1.413	-2.944	-1.101	0.8642	6.7	16.9	25.8	56.2
53	89	2.335	-3.303	-1.083	0.9091	7.9	20.2	24.7	53.9
54	89	0.882	-3.088	-1.102	0.7918	5.6	19.1	25.8	60.7
55	89	0.616	-3.223	-0.936	0.8350	21.3	33.7	43.8	66.3

56	89	1.374	-3.150	-0.897	0.8542	21.3	38.2	48.3	71.9
57	89	0.745	-3.941	-0.882	0.9583	22.5	38.2	44.9	68.5
58	89	0.947	-3.755	-0.901	0.9693	28.1	36.0	42.7	65.2
59	89	4.048	-4.340	-0.848	1.2339	19.1	36.0	40.4	62.9
60	87	3.148	-4.270	-0.755	1.1506	18.4	29.9	40.2	64.4
61	87	3.052	-4.971	-0.512	1.2867	21.8	35.6	46.0	66.7
62	87	5.069	-4.878	-0.251	1.7722	20.7	34.5	39.1	58.6
63	87	5.706	-3.940	-0.415	1.6293	21.8	31.0	33.3	55.2
64	87	0.685	-5.524	-1.005	1.2122	18.4	29.9	37.9	67.8
65	89	0.954	-5.769	-1.202	1.2408	13.5	22.5	28.1	48.3
66	89	0.505	-6.136	-1.350	1.2356	14.6	24.7	29.2	41.6
67	89	0.877	-5.662	-1.207	1.2264	13.5	21.3	24.7	48.3
68	89	0.362	-6.274	-1.284	1.1967	11.2	21.3	22.5	49.4
69	89	0.272	-5.562	-1.378	1.1422	13.5	15.7	24.7	43.8
70	89	0.292	-5.119	-1.316	1.1389	14.6	25.8	32.6	41.6
71	89	0.187	-5.174	-1.290	1.1262	16.9	21.3	27.0	46.1
72	89	0.149	-5.039	-1.333	1.0227	10.1	15.7	23.6	42.7
73	89	0.529	-4.647	-1.139	1.0951	20.2	33.7	43.8	58.4
74	89	0.266	-4.656	-1.179	1.0181	16.9	24.7	31.5	56.2
75	89	0.284	-4.092	-1.247	0.9000	13.5	18.0	22.5	48.3
76	89	0.335	-3.692	-1.032	0.9048	20.2	31.5	40.4	62.9
77	89	0.466	-3.545	-1.069	0.8274	12.4	31.5	34.8	55.1
78	89	0.308	-3.400	-1.218	0.7918	6.7	16.9	22.5	46.1
79	89	0.465	-3.361	-0.982	0.8409	16.9	36.0	44.9	60.7
80	89	0.203	-3.404	-1.028	0.7902	13.5	29.2	40.4	58.4
81	89	0.181	-3.176	-1.064	0.7613	18.0	25.8	30.3	58.4
82	89	0.630	-2.805	-0.966	0.7053	14.6	28.1	36.0	60.7
83	89	0.058	-2.939	-1.014	0.6610	9.0	23.6	36.0	60.7
84	89	0.000	-2.570	-1.173	0.6337	5.6	14.6	21.3	48.3
85	89	0.203	-2.429	-0.922	0.6296	14.6	31.5	41.6	64.0
86	89	0.000	-2.828	-0.981	0.5856	11.2	22.5	33.7	64.0
87	89	0.015	-2.393	-1.070	0.6224	4.5	20.2	33.7	59.6
88	89	0.129	-3.274	-0.888	0.6308	14.6	31.5	42.7	69.7
89	89	0.398	-2.794	-0.926	0.6372	10.1	27.0	38.2	70.8
90	89	0.173	-2.665	-0.972	0.6272	16.9	25.8	30.3	64.0
91	89	0.094	-2.665	-0.776	0.6094	28.1	37.1	48.3	78.7
92	89	0.377	-3.063	-0.864	0.7682	25.8	38.2	47.2	66.3
93	89	0.290	-2.600	-0.921	0.6930	23.6	32.6	37.1	70.8
94	89	0.252	-3.159	-0.839	0.7541	23.6	37.1	46.1	76.4
95	89	0.866	-2.453	-0.774	0.7035	23.6	33.7	42.7	74.2
96	89	0.360	-2.671	-0.890	0.7371	22.5	27.0	39.3	66.3
97	89	0.366	-2.681	-0.716	0.7220	33.7	50.6	56.2	77.5
98	89	0.539	-2.502	-0.786	0.7139	18.0	33.7	49.4	74.2
99	89	0.544	-2.826	-0.869	0.8295	18.0	33.7	42.7	67.4
100	89	0.593	-2.784	-0.657	0.6870	20.2	39.3	57.3	82.0
101	89	0.547	-2.822	-0.731	0.7703	24.7	40.4	53.9	75.3
102	89	0.673	-2.457	-0.774	0.6998	22.5	25.8	42.7	74.2
103	89	0.909	-1.721	-0.466	0.6046	28.1	44.9	58.4	89.9
104	89	0.847	-1.812	-0.554	0.6303	27.0	41.6	58.4	82.0
105	89	0.475	-2.125	-0.612	0.6135	32.6	44.9	59.6	84.3
106	89	0.669	-1.867	-0.453	0.5496	36.0	61.8	70.8	88.8
107	89	0.441	-1.629	-0.457	0.4918	37.1	58.4	76.4	88.8
108	89	0.688	-2.164	-0.555	0.6127	28.1	41.6	55.1	86.5
109	89	0.995	-1.806	-0.497	0.5816	33.7	53.9	65.2	87.6
110	89	2.044	-1.987	-0.381	0.6640	34.8	50.6	70.8	88.8
111	89	1.824	-2.254	-0.507	0.7138	21.3	46.1	64.0	83.1
112	89	1.751	-1.978	-0.244	0.6807	33.7	51.7	68.5	88.8
113	89	2.277	-1.833	-0.273	0.6616	34.8	50.6	68.5	91.0
114	89	1.841	-1.621	-0.409	0.7038	25.8	44.9	55.1	82.0
115	89	3.202	-2.515	-0.409	0.7411	30.3	47.2	67.4	87.6
116	89	2.527	-1.534	-0.377	0.7727	19.1	33.7	49.4	82.0
117	89	2.426	-2.232	-0.490	0.7882	25.8	37.1	51.7	78.7

Classification report 1 of 3

IHO statistics a/b are : 0.250 0.008

User#	Total	# fail	% fail	# pass	% pass
=====	=====	=====	=====	=====	=====
10	89	34	38.20	55	61.80
11	89	53	59.55	36	40.45
12	89	53	59.55	36	40.45
13	88	37	42.05	51	57.95
14	88	54	61.36	34	38.64
15	87	60	68.97	27	31.03
16	89	64	71.91	25	28.09
17	89	68	76.40	21	23.60
18	89	66	74.16	23	25.84
19	89	58	65.17	31	34.83
20	89	75	84.27	14	15.73
21	89	72	80.90	17	19.10
22	89	56	62.92	33	37.08
23	89	81	91.01	8	8.99
24	89	83	93.26	6	6.74
25	88	65	73.86	23	26.14
26	88	83	94.32	5	5.68
27	88	85	96.59	3	3.41
28	86	73	84.88	13	15.12
29	89	86	96.63	3	3.37
30	89	79	88.76	10	11.24
31	89	70	78.65	19	21.35
32	89	58	65.17	31	34.83
33	89	53	59.55	36	40.45
34	89	41	46.07	48	53.93
35	89	40	44.94	49	55.06
36	89	76	85.39	13	14.61
37	89	43	48.31	46	51.69
38	89	54	60.67	35	39.33
39	89	69	77.53	20	22.47
40	89	66	74.16	23	25.84
41	89	68	76.40	21	23.60
42	89	61	68.54	28	31.46
43	89	62	69.66	27	30.34
44	89	63	70.79	26	29.21
45	89	58	65.17	31	34.83
46	89	69	77.53	20	22.47
47	89	67	75.28	22	24.72
48	89	62	69.66	27	30.34
49	89	70	78.65	19	21.35
50	89	74	83.15	15	16.85
51	89	72	80.90	17	19.10
52	89	72	80.90	17	19.10
53	89	69	77.53	20	22.47
54	89	70	78.65	19	21.35
55	89	59	66.29	30	33.71
56	89	54	60.67	35	39.33
57	89	56	62.92	33	37.08
58	89	54	60.67	35	39.33
59	89	58	65.17	31	34.83
60	87	59	67.82	28	32.18
61	87	54	62.07	33	37.93
62	87	55	63.22	32	36.78
63	87	60	68.97	27	31.03
64	87	58	66.67	29	33.33
65	89	68	76.40	21	23.60
66	89	66	74.16	23	25.84
67	89	70	78.65	19	21.35
68	89	70	78.65	19	21.35
69	89	75	84.27	14	15.73
70	89	63	70.79	26	29.21

71	89	68	76.40	21	23.60
72	89	71	79.78	18	20.22
73	89	58	65.17	31	34.83
74	89	65	73.03	24	26.97
75	89	72	80.90	17	19.10
76	89	57	64.04	32	35.96
77	89	61	68.54	28	31.46
78	89	73	82.02	16	17.98
79	89	53	59.55	36	40.45
80	89	60	67.42	29	32.58
81	89	67	75.28	22	24.72
82	89	62	69.66	27	30.34
83	89	66	74.16	23	25.84
84	89	75	84.27	14	15.73
85	89	57	64.04	32	35.96
86	89	67	75.28	22	24.72
87	89	66	74.16	23	25.84
88	89	60	67.42	29	32.58
89	89	63	70.79	26	29.21
90	89	64	71.91	25	28.09
91	89	54	60.67	35	39.33
92	89	52	58.43	37	41.57
93	89	57	64.04	32	35.96
94	89	54	60.67	35	39.33
95	89	58	65.17	31	34.83
96	89	61	68.54	28	31.46
97	89	43	48.31	46	51.69
98	89	54	60.67	35	39.33
99	89	57	64.04	32	35.96
100	89	49	55.06	40	44.94
101	89	47	52.81	42	47.19
102	89	61	68.54	28	31.46
103	89	44	49.44	45	50.56
104	89	50	56.18	39	43.82
105	89	44	49.44	45	50.56
106	89	32	35.96	57	64.04
107	89	32	35.96	57	64.04
108	89	48	53.93	41	46.07
109	89	36	40.45	53	59.55
110	89	36	40.45	53	59.55
111	89	43	48.31	46	51.69
112	89	34	38.20	55	61.80
113	89	39	43.82	50	56.18
114	89	43	48.31	46	51.69
115	89	40	44.94	49	55.06
116	89	56	62.92	33	37.08
117	89	50	56.18	39	43.82

Classification report 2 of 3

IHO statistics a/b are : 0.500 0.013

User#	Total	# fail	% fail	# pass	% pass
=====	=====	=====	=====	=====	=====
10	89	15	16.85	74	83.15
11	89	20	22.47	69	77.53
12	89	18	20.22	71	79.78
13	88	14	15.91	74	84.09
14	88	24	27.27	64	72.73
15	87	25	28.74	62	71.26
16	89	36	40.45	53	59.55
17	89	44	49.44	45	50.56
18	89	40	44.94	49	55.06
19	89	40	44.94	49	55.06
20	89	49	55.06	40	44.94
21	89	47	52.81	42	47.19
22	89	26	29.21	63	70.79
23	89	63	70.79	26	29.21
24	89	66	74.16	23	25.84
25	88	48	54.55	40	45.45
26	88	74	84.09	14	15.91
27	88	74	84.09	14	15.91
28	86	49	56.98	37	43.02
29	89	75	84.27	14	15.73
30	89	44	49.44	45	50.56
31	89	49	55.06	40	44.94
32	89	25	28.09	64	71.91
33	89	23	25.84	66	74.16
34	89	27	30.34	62	69.66
35	89	18	20.22	71	79.78
36	89	50	56.18	39	43.82
37	89	18	20.22	71	79.78
38	89	28	31.46	61	68.54
39	89	49	55.06	40	44.94
40	89	33	37.08	56	62.92
41	89	35	39.33	54	60.67
42	89	34	38.20	55	61.80
43	89	33	37.08	56	62.92
44	89	28	31.46	61	68.54
45	89	30	33.71	59	66.29
46	89	35	39.33	54	60.67
47	89	39	43.82	50	56.18
48	89	38	42.70	51	57.30
49	89	40	44.94	49	55.06
50	89	44	49.44	45	50.56
51	89	45	50.56	44	49.44
52	89	40	44.94	49	55.06
53	89	46	51.69	43	48.31
54	89	39	43.82	50	56.18
55	89	31	34.83	58	65.17
56	89	30	33.71	59	66.29
57	89	30	33.71	59	66.29
58	89	33	37.08	56	62.92
59	89	39	43.82	50	56.18
60	87	31	35.63	56	64.37
61	87	31	35.63	56	64.37
62	87	37	42.53	50	57.47
63	87	42	48.28	45	51.72
64	87	33	37.93	54	62.07
65	89	47	52.81	42	47.19
66	89	55	61.80	34	38.20
67	89	50	56.18	39	43.82
68	89	48	53.93	41	46.07
69	89	52	58.43	37	41.57
70	89	52	58.43	37	41.57

71	89	51	57.30	38	42.70
72	89	54	60.67	35	39.33
73	89	39	43.82	50	56.18
74	89	40	44.94	49	55.06
75	89	48	53.93	41	46.07
76	89	34	38.20	55	61.80
77	89	41	46.07	48	53.93
78	89	51	57.30	38	42.70
79	89	36	40.45	53	59.55
80	89	39	43.82	50	56.18
81	89	40	44.94	49	55.06
82	89	35	39.33	54	60.67
83	89	37	41.57	52	58.43
84	89	50	56.18	39	43.82
85	89	35	39.33	54	60.67
86	89	38	42.70	51	57.30
87	89	41	46.07	48	53.93
88	89	32	35.96	57	64.04
89	89	32	35.96	57	64.04
90	89	38	42.70	51	57.30
91	89	23	25.84	66	74.16
92	89	35	39.33	54	60.67
93	89	34	38.20	55	61.80
94	89	29	32.58	60	67.42
95	89	27	30.34	62	69.66
96	89	33	37.08	56	62.92
97	89	21	23.60	68	76.40
98	89	28	31.46	61	68.54
99	89	36	40.45	53	59.55
100	89	22	24.72	67	75.28
101	89	26	29.21	63	70.79
102	89	26	29.21	63	70.79
103	89	14	15.73	75	84.27
104	89	21	23.60	68	76.40
105	89	20	22.47	69	77.53
106	89	13	14.61	76	85.39
107	89	11	12.36	78	87.64
108	89	15	16.85	74	83.15
109	89	13	14.61	76	85.39
110	89	12	13.48	77	86.52
111	89	18	20.22	71	79.78
112	89	14	15.73	75	84.27
113	89	12	13.48	77	86.52
114	89	21	23.60	68	76.40
115	89	15	16.85	74	83.15
116	89	21	23.60	68	76.40
117	89	23	25.84	66	74.16

Classification report 3 of 3

IHO statistics a/b are : 1.000 0.023

User#	Total	# fail	% fail	# pass	% pass
=====	=====	=====	=====	=====	=====
10	89	1	1.12	88	98.88
11	89	0	0.00	89	100.00
12	89	2	2.25	87	97.75
13	88	1	1.14	87	98.86
14	88	0	0.00	88	100.00
15	87	4	4.60	83	95.40
16	89	4	4.49	85	95.51
17	89	9	10.11	80	89.89
18	89	8	8.99	81	91.01
19	89	5	5.62	84	94.38
20	89	19	21.35	70	78.65
21	89	14	15.73	75	84.27
22	89	10	11.24	79	88.76
23	89	29	32.58	60	67.42
24	89	32	35.96	57	64.04
25	88	17	19.32	71	80.68
26	88	47	53.41	41	46.59
27	88	41	46.59	47	53.41
28	86	29	33.72	57	66.28
29	89	38	42.70	51	57.30
30	89	17	19.10	72	80.90
31	89	20	22.47	69	77.53
32	89	4	4.49	85	95.51
33	89	3	3.37	86	96.63
34	89	4	4.49	85	95.51
35	89	2	2.25	87	97.75
36	89	11	12.36	78	87.64
37	89	4	4.49	85	95.51
38	89	4	4.49	85	95.51
39	89	13	14.61	76	85.39
40	89	7	7.87	82	92.13
41	89	8	8.99	81	91.01
42	89	7	7.87	82	92.13
43	89	7	7.87	82	92.13
44	89	4	4.49	85	95.51
45	89	5	5.62	84	94.38
46	89	7	7.87	82	92.13
47	89	10	11.24	79	88.76
48	89	9	10.11	80	89.89
49	89	14	15.73	75	84.27
50	89	13	14.61	76	85.39
51	89	13	14.61	76	85.39
52	89	14	15.73	75	84.27
53	89	15	16.85	74	83.15
54	89	13	14.61	76	85.39
55	89	10	11.24	79	88.76
56	89	10	11.24	79	88.76
57	89	14	15.73	75	84.27
58	89	12	13.48	77	86.52
59	89	11	12.36	78	87.64
60	87	11	12.64	76	87.36
61	87	10	11.49	77	88.51
62	87	18	20.69	69	79.31
63	87	18	20.69	69	79.31
64	87	8	9.20	79	90.80
65	89	14	15.73	75	84.27
66	89	19	21.35	70	78.65
67	89	16	17.98	73	82.02
68	89	12	13.48	77	86.52
69	89	16	17.98	73	82.02
70	89	21	23.60	68	76.40

71	89	13	14.61	76	85.39
72	89	18	20.22	71	79.78
73	89	16	17.98	73	82.02
74	89	15	16.85	74	83.15
75	89	13	14.61	76	85.39
76	89	14	15.73	75	84.27
77	89	8	8.99	81	91.01
78	89	12	13.48	77	86.52
79	89	12	13.48	77	86.52
80	89	8	8.99	81	91.01
81	89	13	14.61	76	85.39
82	89	9	10.11	80	89.89
83	89	7	7.87	82	92.13
84	89	8	8.99	81	91.01
85	89	6	6.74	83	93.26
86	89	4	4.49	85	95.51
87	89	7	7.87	82	92.13
88	89	6	6.74	83	93.26
89	89	5	5.62	84	94.38
90	89	2	2.25	87	97.75
91	89	3	3.37	86	96.63
92	89	5	5.62	84	94.38
93	89	6	6.74	83	93.26
94	89	8	8.99	81	91.01
95	89	5	5.62	84	94.38
96	89	5	5.62	84	94.38
97	89	5	5.62	84	94.38
98	89	4	4.49	85	95.51
99	89	7	7.87	82	92.13
100	89	1	1.12	88	98.88
101	89	3	3.37	86	96.63
102	89	4	4.49	85	95.51
103	89	0	0.00	89	100.00
104	89	0	0.00	89	100.00
105	89	0	0.00	89	100.00
106	89	0	0.00	89	100.00
107	89	0	0.00	89	100.00
108	89	1	1.12	88	98.88
109	89	0	0.00	89	100.00
110	89	1	1.12	88	98.88
111	89	1	1.12	88	98.88
112	89	1	1.12	88	98.88
113	89	1	1.12	88	98.88
114	89	0	0.00	89	100.00
115	89	3	3.37	86	96.63
116	89	1	1.12	88	98.88
117	89	3	3.37	86	96.63

Leadline RA 6S (located in 1015)
 calibrated 3/11/2004

Meter Marks	Measurement	Corrector
1.0	1.0	0.0
2.0	2.0	0.0
3.0	3.0	0.0
4.0	4.0	0.0
5.0	5.0	0.0
6.0	6.0	0.0
7.0	7.0	0.0
8.0	8.0	0.0
9.0	9.0	0.0
10.0	10.0	0.0
11.0	11.0	0.0
12.0	12.0	0.0
13.0	13.0	0.0
14.0	14.0	0.0
15.0	15.0	0.0
16.0	16.0	0.0
Average Correction		0.000
Standard deviation		0.000

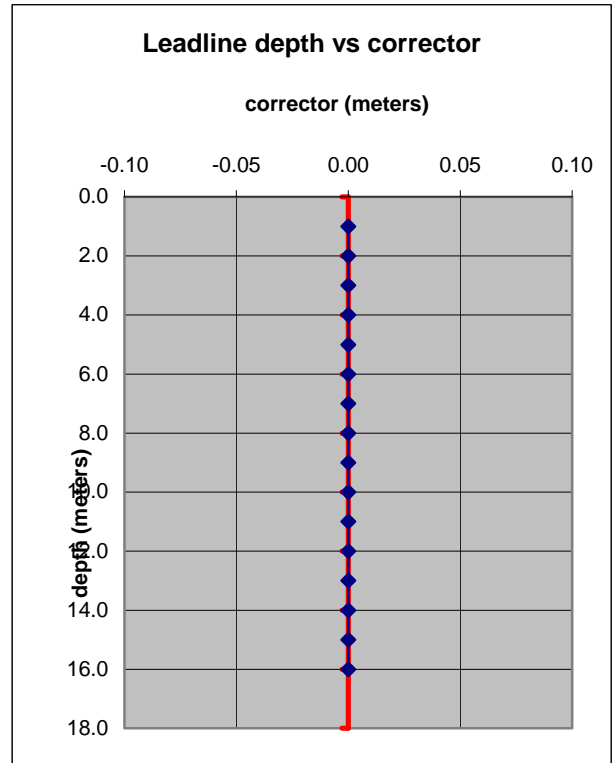

Note: Markers on leadline RA 6S were retied in exact locations

Leadline RA204 (unlabeled, located in 1101)
 calibrated 3/11/2004

Meter Mark	Measurement	Corrector
1.0	1.000	0.000
2.0	2.000	0.000
3.0	3.000	0.000
4.0	4.000	0.000
5.0	5.000	0.000
6.0	6.000	0.000
7.0	7.000	0.000
8.0	8.000	0.000
9.0	9.000	0.000
10.0	10.000	0.000
11.0	11.000	0.000
12.0	12.000	0.000
13.0	13.000	0.000
14.0	14.000	0.000
15.0	15.000	0.000
16.0	16.000	0.000
17.0	17.000	0.000
18.0	18.000	0.000
19.0	19.000	0.000
20.0	20.000	0.000
21.0	21.000	0.000
22.0	22.000	0.000
23.0	23.000	0.000
24.0	24.000	0.000
25.0	25.000	0.000
Average Correction		0.000
Standard deviation		0.000

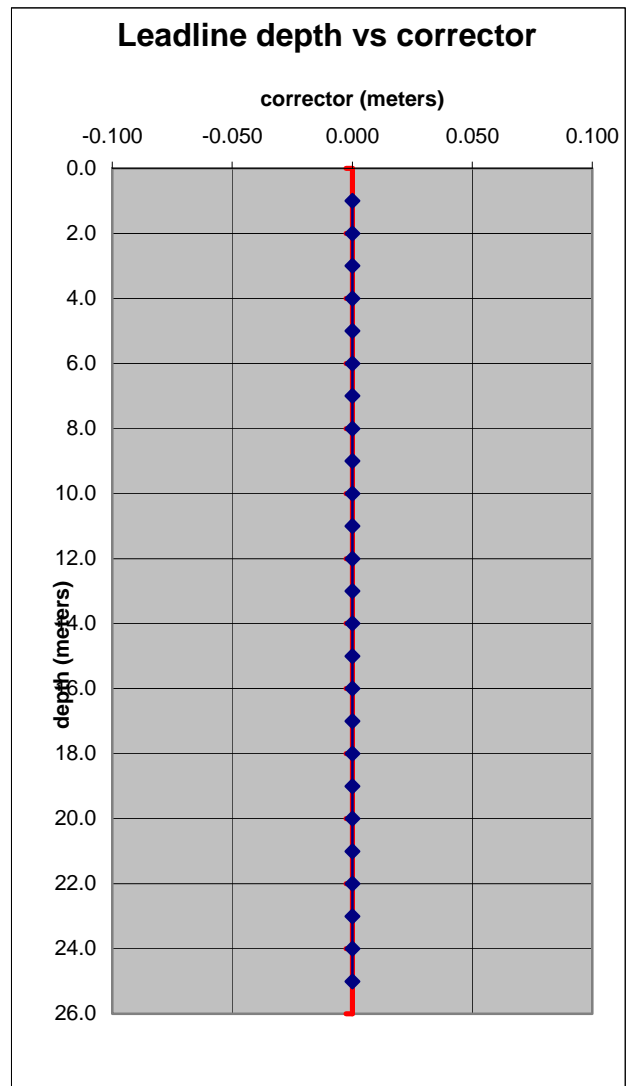

Note: Markers on RA204 were retied in exact 1 m increments

Lead Line RA107 (located in 817)
 calibrated 3/11/2004

Meter Mark	Measurement	Corrector
1.0	1.0	0.0
2.0	2.0	0.0
3.0	3.0	0.0
4.0	4.0	0.0
5.0	5.0	0.0
6.0	6.0	0.0
7.0	7.0	0.0
8.0	8.0	0.0
9.0	9.0	0.0
10.0	10.0	0.0
11.0	11.0	0.0
12.0	12.0	0.0
13.0	13.0	0.0
14.0	14.0	0.0
15.0	15.0	0.0
16.0	16.0	0.0
17.0	17.0	0.0
18.0	18.0	0.0
19.0	19.0	0.0
20.0	20.0	0.0
Average Correction		0.000
Standard deviation		0.000

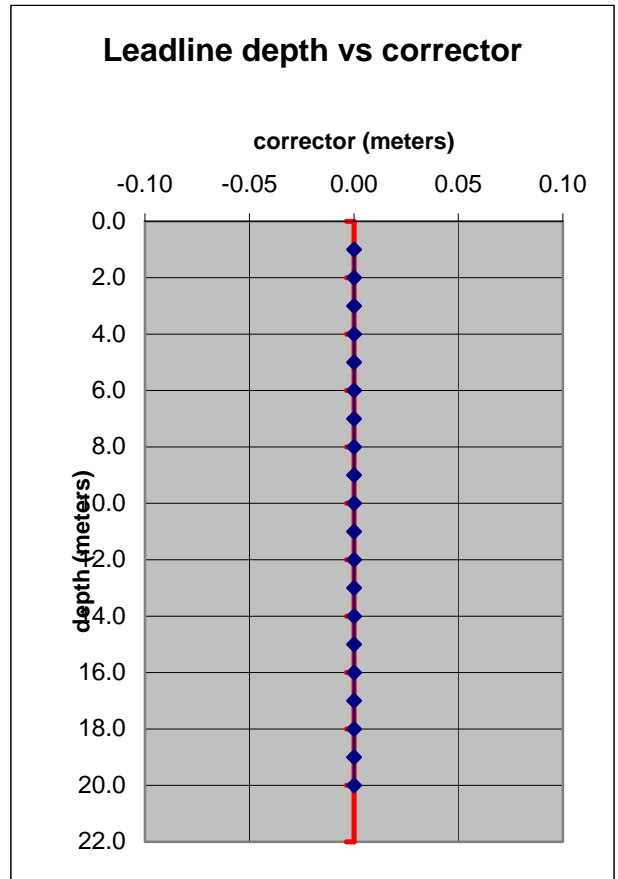

Note: Markers on leadline RA107 were retied in exact 1 m increments

Lead Line RA201 (located on 1103)

calibrated 3/11/2004

Meter Mark	Measurement	Corrector
1.0	1.065	-0.065
2.0	1.995	0.005
3.0	2.975	0.025
4.0	3.965	0.035
5.0	4.975	0.025
6.0	5.963	0.037
7.0	6.970	0.030
8.0	7.963	0.037
9.0	8.992	0.008
10.0	10.010	-0.010
11.0	10.985	0.015
12.0	11.980	0.020
13.0	12.993	0.007
14.0	13.995	0.005
15.0	15.002	-0.002
16.0	16.048	-0.048
17.0	17.057	-0.057
18.0	18.048	-0.048
19.0	19.060	-0.060
20.0	20.059	-0.059
21.0	21.073	-0.073
22.0	22.072	-0.072
23.0	23.070	-0.070
24.0	24.075	-0.075
25.0	25.062	-0.062
Average Correction		-0.018
Standard deviation		0.042

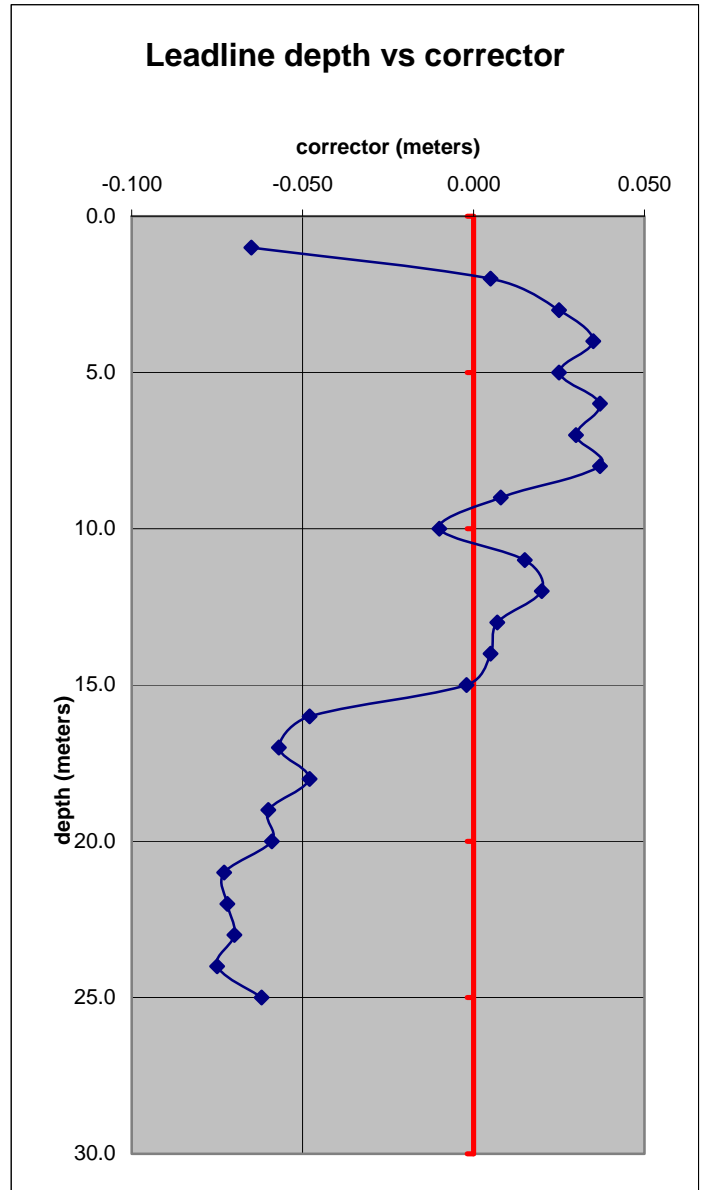

Lead Line RA3 S

calibrated 3/11/2004

Meter Marks	Measurement	Corrector
1.00	1.00	0.00
2.00	2.00	0.00
3.00	3.00	0.00
4.00	4.00	0.00
5.00	5.00	0.00
6.00	6.00	0.00
7.00	7.00	0.00
8.00	8.00	0.00
Average Correction		0.000
Standard deviation		0.000

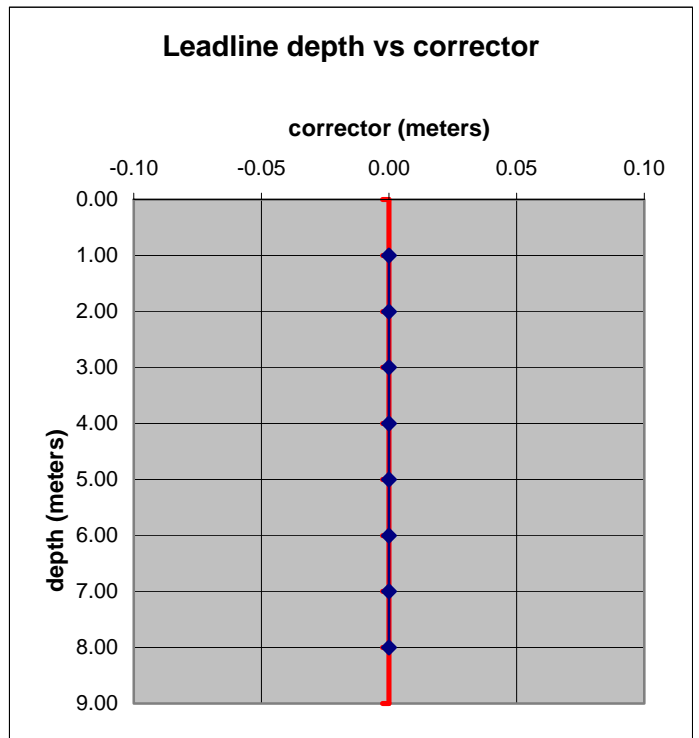

Note: The markers on RA 3 S were retied in exact 1 m increments

Lead Line RA203

calibrated 3/11/2004

Meter Mark	Measurement	Corrector
1.0	1.0	0.0
2.0	2.0	0.0
3.0	3.0	0.0
4.0	4.0	0.0
5.0	5.0	0.0
6.0	6.0	0.0
7.0	7.0	0.0
8.0	8.0	0.0
9.0	9.0	0.0
10.0	10.0	0.0
11.0	11.0	0.0
12.0	12.0	0.0
13.0	13.0	0.0
14.0	14.0	0.0
15.0	15.0	0.0
16.0	16.0	0.0
17.0	17.0	0.0
18.0	18.0	0.0
19.0	19.0	0.0
20.0	20.0	0.0
Average Correction		0.000
Standard deviation		0.000

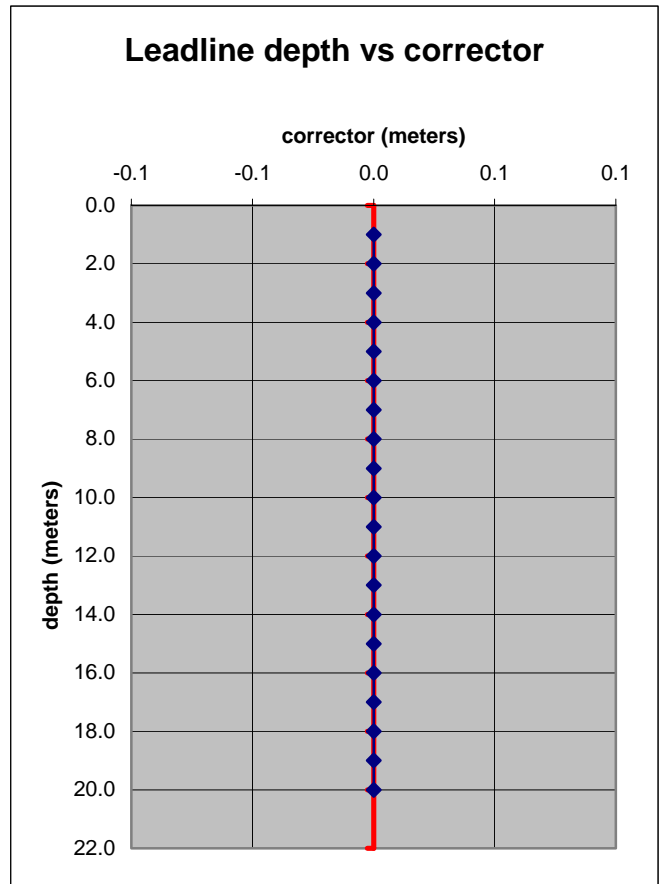

Note: Markers on leadline RA203 were retied in exact 1 m increments