

Data Acquisition and Processing Report

NOAA Ship RAINIER

OPR-P132-RA-04

Eastern Prince William Sound, Alaska

Hydrographic Letter Instructions dated July 20, 2004

Chief of Party: Commander John W. Humphrey, NOAA

A. EQUIPMENT

This Data Acquisition and Processing Report (DAPR) describes both the survey equipment used and the standard methods for acquisition applied to the equipment used. Not necessarily all equipment described within this report was used during data acquisition for all sheets of this project. Data were acquired by the following RAINIER survey launches:

<u>Hull Number</u>	<u>Vessel type</u>
817	17 foot SeaArk survey skiff
1101	29 foot Jensen jet drive survey launch
1103	28 foot Munson jet drive work boat
1021	29 foot Jensen survey launch
1016	29 foot Jensen survey launch
1006	29 foot Jensen survey launch
1015	29 foot Jensen survey launch

Vessels 1021, 1016, 1006 and 1015 were used to acquire shallow-water multibeam (SWMB) data and sound velocity profiles. Vessels 817, 1101 and 1103 were used to collect vertical-beam echosounder (VBES) data and detached positions. Any vessel may be utilized for collecting bottom samples. No unusual vessel configurations or problems were encountered on this project. Vessel descriptions and offset measurements are included in Appendix III of this report.

Four different categories of echosounder systems were utilized for project OPR-P132-RA-04. The individual system(s) chosen for use in a given area were decided at the discretion of the Hydrographer using the guidance stated in the Standing Project Instructions, the Hydrographic Letter Instructions, and the Field Procedures Manual. Echosounder use was also depended upon the limitations of each system, the bottom topography, the water depth, and the ability of the platform vessel to safely navigate the area. These systems are described in the following section.

Sounding Equipment:

1. RESON 8101 Launch Shallow-Water Multibeam (SWMB)

Vessel 1021 is equipped with a Reson SeaBat 8101 mounted on a swing-arm. This system deploys the transducer from an "in transit" position recessed within the hull to a "survey" position extending beneath the hull once data collection commences. Vessel 1006 is equipped with a hull-mounted Reson SeaBat 8101. Both of these Reson SeaBat 8101s are equipped with option 033, Angle-Independent Imagery, and option 040, Extended Range Projector. The SeaBat 8101 is a 240 kHz multibeam system that measures relative water depths across a 150° swath, consisting of 101 individual 1.5° x 1.5° beams. This system was used to obtain full-bottom coverage in depths generally from 4 meters to 200 meters, with varying range scale values dependent upon the depth of water and across-track slope.

2. RESON 8125 Launch Shallow-Water Multibeam (SWMB)

Vessel 1016 is equipped with a hull-mounted Reson SeaBat 8125, with option 033, Angle-Independent Imagery. The SeaBat 8125 is a 455 kHz multibeam system that uses high frequency focused near-field beam forming to measure relative water depths across a 120° swath, consisting of 240 individual 0.5° x 1.0° beams. This system was used to obtain full-bottom coverage in depths generally from 4 meters to 60 meters, with varying range scale values dependent upon the depth of water and across-track slope. Surface sound velocity was measured using an Odom Digibar Pro, model db1200, velocimeter and digitally input into the Seabat 8125 during acquisition.

3. ELAC 1180 Launch Shallow-Water Multibeam (SWMB)

Vessels 1016 and 1015 are equipped with a hull-mounted Elac 1180, which is a single frequency (180 kHz), multibeam echosounder system for shallow and intermediate water depths. The transducer assembly consists of two flat-faced transducers, one starboard and one port, each mounted at a 38° angle from horizontal. Echosounding is achieved using a Rotating Directional Transmission (RDT) method where sound is directed utilizing the directional gain of the complete transducer array. Sonar transmission occurs across adjacent sectors in a 3-step “subfan” process. Out of each of the 3 subfans within a sector, the receiving beamformer calculates 3 slightly overlapping beams each 1.5° wide with a spacing of 1.25°, for a total of 9 beams per sector. There are 7 fanwidth settings possible, the maximum of which (153.5°) utilizes 7 sectors, for a maximum total of 126 beams within a “virtual swath”. The Elac 1180 was generally used in depths of 50 to 100 meters with an acquisition swath width of 131°. Narrower fanwidth settings were selected at the discretion of the hydrographer in waters in between 100 and 300 meters of depth dependant upon both local conditions and the quality of the bottom trace. Surface sound velocity was measured using an Odom Digibar Pro, model db1200, velocimeter and digitally input into the Hydrostar computer during acquisition.

4. Launch Vertical-Beam Echosounder (VBES)

Vessels 817, 1101 and 1103 are equipped with a Knudsen Engineering Limited 320M, which is a dual frequency (100 kHz, 24 kHz) digital recording vertical-beam echo sounder with an analog paper record. The beam widths for the high and low frequency are 7° and 25° respectively. Soundings were acquired in meters for both frequencies, with high frequency utilized as the primary frequency in Hypack. Frequently, the low frequency was disabled in shallow water because it distorted the echosounder trace.

VBES data were collected in near shore areas to define the four-meter curve and the limit of SWMB hydrography. Data were also collected over offshore reefs and shoals, in depths generally ranging from 4 to 20 meters. Sounding lines were run perpendicular to depth contours at a line spacing sufficient to generalize the near shore contours, with splits run at a reduced line spacing to develop shoal areas that were deemed too shallow for the safe or effective use of a vessel equipped with SWMB.

5. Diver Least-Depth Gauge

A diver least-depth gauge (DLDG) was utilized to obtain least depths over selected rocks and features. The DLDG utilized by RAINIER, S/N 68332, was last calibrated on June 30, 2003. A copy of the calibration report is included in Appendix IV. The depth gauge measures pressure, and is combined with a CTD profile using VelocWin software to determine depth. These depths were processed in Pydro along with the corresponding detached position (DP).

6. Lead Line

During shoreline verification, lead lines were used to acquire depths over rocks and other features too shallow to acquire soundings using echo sounders. RAINIER personnel calibrated lead lines in March 2004. Calibration reports are included in Appendix IV of this report.

Side Scan Sonar

All the SWMB used by the RAINIER provide a low-resolution digital SSS record of the multibeam swath. This SSS imagery is primarily used during processing of the multibeam depth data to aid in determining whether anomalous soundings are true features or noise.

Positioning Equipment:

Vessels 817, 1101 and 1103 are equipped with a Trimble DSM212L to measure and calculate position. The DSM212L is an integrated 12-channel GPS receiver and dual-channel DGPS beacon receiver. The beacon receiver can simultaneously monitor two independent U.S. Coast Guard (USCG) DGPS beacons. There are three modes: Auto-Range, which locks onto the beacon nearest the vessel; Auto-Power, which locks onto the beacon with the greatest signal strength; and Manual, which allows the user to select the desired beacon. Additionally, the DSM212L can accept differential correctors (RTCM messages) from an external source such as a user-established DGPS reference station. The DSM212L was configured in the manual mode to use only correctors from the nearest USCG beacon, to go off-line if the age of DGPS correctors exceeded 20 seconds, and to exclude satellites with an altitude below 8 degrees.

The following parameters were monitored in real-time through Trimble's TSIPTalker software to ensure position data quality:

- number of satellites used in the solution
- horizontal dilution of precision (HDOP)
- latency of correctors
- beacon signal strength

Vessels 1021, 1016, 1106 (1006?), and 1015 are equipped with a TSS POS/MV Position and Orientation Sensor to measure and calculate position. The POS/MV is a GPS-aided inertial navigation system, which provides a blended position solution derived from both an Inertial Motion Unit (IMU) and an integrated GPS receiver. The IMU and GPS receiver are complementary sensors, and data from one are used to filter and constrain errors from the other. This inter-dependence results in higher position accuracy and fewer errors than either system could produce by itself. Position accuracy is displayed in real time by the POS/MV software and was monitored to ensure that positioning accuracy requirements as outlined in the NOS Hydrographic Surveys Specifications and Deliverables were not exceeded. In addition, the POS/MV software displays HDOP and number of satellites used in position computation. Data acquisition was generally halted when an HDOP of 2.5 was exceeded or the number of satellites available dropped below four. However, because positional accuracy can be maintained by the POS/MV through short GPS outages with the help of the IMU, data acquisition was not halted during short periods of time when the HDOP and number of satellites used exceeded stated parameters.

Software:

Launch 1021 was upgraded for precise timing on March 14th and launches 1016 and 1006 were upgraded over the 4th of July holiday import. Due to this upgrade for precise timing, both position and attitude data from the POS/MV and Reson SWMB echosounder data were recorded using Triton-Elics' ISIS software version 6.5 and logged in the Extended Triton Format (XTF).

Launches 1016 and 1015 recorded Elac 1180 SWMB echosounder data, along with position and attitude data using Elac's Hydrostar software version 3.4.0.1 and logged in the Hydrostar exchange format (XSE).

All SWMB data were processed using the CARIS Hydrographic Information Processing System (HIPS) and Hydrographic Data Cleaning System (HDCS) software for the windows environment.

All VBES data were acquired using Coastal Oceanographic's HYPACK MAX version 02.12a, in the "RAW" format. VBES data were processed using CARIS HIPS for the windows environment.

Coastal Oceanographic's HYPACK MAX version 02.12a was used for vessel navigation and line tracking during acquisition of both VBES and SWMB data. HYPACK MAX was also used to quick mark targets that were processed as detached positions using Pydro supplied by the NOS Hydrographic Systems and Technology Programs N/CS11 (HSTP).

Sound velocity profiles were computed from raw pressure, temperature, and conductivity measurements using VelocWin 8.40 supplied by the NOS Hydrographic Systems and Technology Programs N/CS11 (HSTP).

A complete list of software and versions is included in Appendix I.

B. DATA PROCESSING AND QUALITY CONTROL

Shallow-Water Multibeam Data

Shallow-water multibeam data were monitored in real-time using the 2-D and 3-D data display windows in Isis and the on-screen display for the Reson sonar systems. The Elac HydroStar online bathymetry data display was monitored in real-time for Elac sonar systems. Adjustable user parameters common for all sonars are range scale, power, gain, and pulse width. In addition the swath width and bottom slope type are additional user parameters used during acquisition for the Elac 1180. These parameters were adjusted as necessary to ensure the best data quality. Additionally, vessel speed was adjusted as necessary, and in accordance with the NOS Specifications and Deliverables and Draft Standing Project Instructions, to ensure the required along-track coverage for object detection.

Following acquisition, both Reson and Elac shallow-water multibeam data were processed using the CARIS HIPS and SIPS Batch Processor. This batch processor, running a user defined script, converted both Reson XTF data and Elac XSE data to the HDCS data format. After conversion, all soundings beyond a maximum angle of 60° off-nadir were rejected in accordance with the Draft Standing Project Instructions to reduce both the noise and refraction errors possible in the outer beams. Soundings with poor quality flags, 0 for Reson and 3 for Elac, were also rejected. As a final step of the batch processor, depth, position and attitude data were merged with sound velocity, tide, vessel offset, and dynamic draft correctors to compute the corrected depth and position of each sounding.

All data were initially reviewed with the HDCS program SwathEdit. All soundings were reviewed and obvious depth fliers were identified and manually flagged as "rejected". Vessel positioning and attitude data from each system were similarly displayed and manually cleaned. Fliers or gaps in positioning and attitude data were rejected and interpolated for small periods in time and outright rejected for larger periods in time in which the characteristic of the curve was ambiguous. Additionally, when it was felt that the quality of the data was reduced due to environmental conditions such as sea conditions or extreme variance in sound velocity, data were filtered to a lesser swath width to ensure data quality. Specific data quality factors are discussed in the Descriptive Report for each survey.

All soundings were then again reviewed, spatially referenced with the CARIS HIPS and SIPS Subset Editor. Data were compared with adjacent lines and crosslines, for systematic errors such as tide or sound velocity errors. Questionable soundings were also compared with adjacent or overlapping data for confirmation or further rejection. Depth fliers and noisy data that were not rejected in SwathEdit were rejected in Subset Mode.

New to CARIS HIPS and SIPS version 5.4 is the Bathymetry Associated with Statistical Error (BASE) surface. The BASE surface is a multi-attributed, geo-referenced, statistical representation of the seafloor. To calculate a BASE surface, the horizontal and vertical uncertainty values of each sounding is weighed to find the value of the BASE surface at any given point. The weight of any given sounding is based on it's spatial uncertainty which is determined by finding it's Total Propagated Error (TPE). The TPE is an estimated value that is derived from the combination of all individual error sources. Errors such as measurement and sound velocity errors, tidal measurement and modeling errors, and data processing errors all contribute to TPE. In HIPS, errors are read from the VesselConfig.xml and the DeviceModels.xml files.

To accommodate TPE calculations, CARIS changed the structure of the CARIS Vessel Configuration File (VCF) to the HIPS Vessel File (HVF). The HVF, in addition to containing all the offsets and system biases of a VCF, now include error estimates for tides and zoning, latency, sensor offset measurements, attitude and navigation measurements, draft measurements, and sound velocity measurements. In addition, the HVF specifies which type of sonar system the vessel is using. This, in turn, points to the DeviceModels.xml file which contains error estimates for several sonar types.

One of the sonar systems currently in use aboard the RAINIER, the Elac 1050D, is not yet available for selection in the CARIS DeviceModels.xml file. In it's place the device model for the Elac 1180 was selected since the high frequency option of the Elac 1050D is essentially the same system as the Elac 1180.

Once TPE has been calculated for all soundings, a BASE surface can be generated. Under ideal circumstances, gridding should be done at the finest resolution that the data density will allow. Typically, deeper areas are gridded at a courser resolution than shoaler areas where the data density is greater. At the time this document was generated, no tools existed in CARIS to vary grid resolution by depth. To circumvent this problem, RAINIER decided to base gridding resolutions on the sonar system since depth is the primary deciding factor on the type of system used. This is a rough workaround to grid based on depth. Below is a table of grid resolutions used based on each system type:

System	Resolution (meters)
Reson 8125	5
Reson 8101	5
VBES	10
Elac 1180	10
Elac 1050D	10

Two weighting schemes are available for the BASE surface. Swath angle weighting is based on a beam's intersection angle with the seafloor whereas uncertainty weighting is based on depth uncertainty. Uncertainty weighting was used exclusively in BASE surface generation because a swath angle-weighted grid does not contain an estimate of statistical error as does an uncertainty-weighted BASE surface.

If HDCS data is cleaned using only the BASE surface as a guide, soundings which traditionally would have been rejected as fliers may be left with the accepted flag in the final HDCS dataset. This situation can occur if the magnitude of these fliers' TPE is so great that these soundings have next to no influence on the BASE surface. It is important to note that if a survey is cleaned based solely on BASE surface processing, only the BASE surface can be used to generate the final sounding dataset. If an attempt was made to use the HDCS data in a shoal biased binning process, these fliers would come right through.

Although the RAINIER had the capability to generate BASE surfaces as the final product during project OPR-P132, the decision was made to process all surveys in the traditional line by line swath editing and shoal bias binning process. This decision was based on both the immature software tools available as well as the lack of a technical directive from HSD granting permission for NOAA field units to process hydrographic survey data using BASE surfaces at the time individual sheets were being processed.

RAINIER did generate BASE surfaces for all the sheets associated with this project but used them purely as aids to data cleaning.

Base surfaces were also sun-illuminated with varied degrees of illumination angle and vertical exaggeration to demonstrate coverage and to further check for systematic errors such as tide, sound velocity, or attitude and/or timing errors. Sun-illuminated BASE surfaces generated for quality-assurance purposes were created using CARIS NT at a 5-meter resolution.

A statistical analysis of all SWMB systems is performed using the CARIS HIPS Quality Control Report (QCR) function. At the beginning of the field season, each SWMB system either ran two sets of orthogonal lines at the deeper end of its designed depth range or one set of lines over a reference surface for a beam-by-beam comparison in order to statistically determine the accuracy of each beam. Beams not meeting accuracy requirements as described in the NOS Hydrographic Surveys Specifications and Deliverables were further filtered and rejected. Results from each system's QCR can be found in Appendix IV.

Additionally, a number of crosslines greater than 5% of mainscheme lines were run on each survey. A number of checkpoints were selected at intersections of these crosslines with the mainscheme in survey areas with homogeneous seafloors. A checkpoint report based on IHO order one depth accuracy standards was then generated using Pydro and is submitted digitally in the quality control folder. This report is not submitted as a hard copy appendix of the DR due to its size. Crosslines were also manually compared to the mainscheme lines in CARIS subset mode for an additional qualitative QC comparison that is discussed in the DR for each survey.

Vertical-Beam Echosounder Data

Following data acquisition, vertical-beam echosounder data were converted from HYPACK to the CARIS HDCS format using the Hypack format in the CARIS HIPS Conversion Wizard. VBES data were processed using CARIS HIPS Single-Beam Editor ("SBEdit"). Obvious fliers were rejected, and analog fathograms of vertical-beam echo soundings were compared graphically with digital data in SBEdit to ensure that peaks of shoals and abrupt changes in slope were properly digitized by the echosounder. After review and cleaning in SBEdit, data were merged using the HDCS program HDCSLineMerge with sound velocity, tide, vessel offset, and dynamic draft correctors to compute the corrected depth and position of each VBES sounding.

Detached Position Data

The primary purpose of detached positions (DP's) is to verify and define shoreline features (ex: rocks, reefs ledges, piles), disprove charted features, position navigational aids and landmarks (ex: buoys, beacons, lights), and mark positions of bottom samples. DPs were captured in the field as quick mark targets in HYPACK by hitting the f5 key. Additional edits to the targets (range, bearing, depth and notes) were performed by editing target parameters with the f6 key in HYPACK. Concurrent with the acquisition these DP's, digital photographs were taken of most features which were exposed above the waterline.

Following acquisition, target files (TGT) were edited when applicable to correct magnetic bearings for local variance so that all bearing were true. Additionally, DP names were changed to the format *vvvv_ddd_nnn* where *vvvv* is the vessel's hull number, *ddd* is the day of year and *nnn* is the position number (Ex: DP **1101_099_118** is the 118th position taken by vessel 1101 on day number 099). Finally the TGT files were saved with naming convention DP_*vvvv_ddd*.tgt for DPs and BS_*vvvv_ddd*.tgt for bottom samples. A vessel configuration representing the majority of the targets was selected and TGT files were converted to HDCS format data using Pydro. Digital photos were renamed to match their respective DP's fix number and moved into a single folder. Final DP attribution, correction of vessel configurations, and linkage to digital photos were the preformed using Pydro. Any required application of tide and SV corrections were performed in CARIS HIPS.

S-57 Attribution

All Pydro XML features marked as “primary” were edited to have their object/attribute instances describe each feature as completely as possible. In some cases this required that multiple object classes be assigned to a single feature. Object attributes assigned to each feature conform to direction located within both the draft “S57 PYDRO guide” and the CARIS “IHO S-57/ENC Object and Attribute Catalogue”.

Data Decimation and Field Sheet Production

All SWMB and VBES soundings were combined in the same HDCS project. To produce the reduced data set used to create the final field sheet, all non-rejected soundings having passed all other quality-assurance checks were imported into a Pydro Preliminary Smooth Sheet (PSS) file using shoal-biased “line-by-line” binning using a cell size of 1.5 millimeters x 1.5 millimeters at survey scale. The resultant thinned data were then excessed in Pydro using a 3-millimeter character size, ensuring that the largest spacing between selected soundings would not exceed 5 millimeters at survey scale. Final selected soundings were exported to MapInfo from Pydro using HP tools and plotted in MapInfo at a 2-millimeter character size. Data processing flow diagrams are included in Appendix II of this report.

Pydro Processing & Reports

Pydro is capable of producing a number of different reports based on standard report templates built into the program in addition to user selected filters and feature trees. All reports generated in Pydro are saved in the Adobe Acrobat PDF format. Reports generated for inclusion with DRs include shoreline, AWOIS, DTON, and request for tides reports.

The shoreline report is generated by selecting the “For Descriptive Report” option. This generates a report detailing all features flagged “Report” in Pydro in addition to all dangers to navigation.

Any item selected as a DTON must be classified as a feature in Pydro. For a sounding, this is accomplished in the Pydro Feature Cumulative Grid by selecting the individual sounding of interest and with a right click “Make Feature”. The resultant feature is then flagged Primary - Significant - Chart – DTON – Resolved. Once all selected DTONs are flagged features, a report is generated by selecting **Reports > Danger to Navigation**. This generates both a .PDF file and an .XML file with the naming convention of “Hxxxxx_DT0N1.xml”. In addition, the generation of this report also flags all DTONs as Submitted. Any subsequent DTONs discovered are similarly made features and flagged as previously instructed. Running **Reports > Danger to Navigation** again, with the naming convention of “Hxxxxx_DT0N2.xml” for the second submission, will generate a report with DTONs not previously flagged as submitted.

Prior to generating an AWOIS report, the AWOIS database provided with the project instructions is edited to be sheet specific by deleting all AWOIS items which fall outside of the sheet limits. This sheet specific database is then inserted into the sheet's PSS. If a DP is taken and correlates to the AWOIS item, the DP is marked “Primary” and the corresponding AWOIS item is marked “Secondary”. If an AWOIS item was found or disproved with a multibeam sounding, the sounding is made into a bathy-feature and marked “Primary” and the corresponding AWOIS item is marked “Secondary”. Investigation techniques and methods are entered in the remarks tab of the AWOIS item. Any digital photo taken with a detached position is associated with the DP as usual. When applicable, MapInfo screengrabs displaying the AWOIS search radius with the associated grid in the background were associated with the AWOIS item. With a right mouse click “add to report” any photos or screengrabs may optionally be added to the AWOIS report. The AWOIS report is generated based on a user created feature tree which includes only AWOIS items. The AWOIS report itself is generated under Reports>For Active Tree Template. Once the Feature Report Options screen comes up “AWOIS Report” is entered under **Title**, and “AWOIS Investigations” under **Subject**. The “Show Correlating AWOIS Item # in Summary Table” and “Feature Page Breaks” options are also checked.

C. CORRECTIONS TO ECHO SOUNDINGS

Sound Velocity

Sound velocity profiles were acquired with SeaBird Electronics SeaCat SBE19 and SBE 19Plus Conductivity, Temperature, and Depth (CTD) profilers (S/N 219, 281, 4039, 4114, 4343, and 4443). Raw conductivity, temperature, and pressure data were processed using the program VelocWin version 8.40 which generated sound velocity profiles for CARIS in the .SVP format. VelocWin was also used to generate sound velocity profiles for Elac acquisition in the .SVA format. Calibration reports and dates of the SeaCat profilers are included in Appendix IV of this report.

The speed of sound through the water was determined by a minimum of one cast for every four hours of SWMB acquisition in accordance with the Standing Project Instructions and the NOS Hydrographic Surveys Specifications and Deliverables Manual. Casts were conducted more frequently when changing survey areas or when it was felt that conditions, such as a change in weather, tide, or current, would warrant additional sound velocity profiles. Additionally, drastic changes in the surface sound velocity indicative of the need for a new cast were determined by observation of the real-time display of the Odom Digibar Pro mounted on vessels 1016 and 1015.

The Elac 1180 SWMB system utilized on vessels 1016 and 1015 is a beam-steered flat-faced transducer system which produces the best results when SV correctors are applied to both the transducer-water interface and the water column itself. To correct SV at the face of the transducer, a real time SV value is feed directly into the HydroStar acquisition software from an Odom Digibar Pro, model db1200 velocimeter. To correct beam-steering in the water column, the .SVA file produced by VelocWin is also input into the HydroStar acquisition software and is used until replaced with another .SVA file.

Occasionally, circumstances would dictate taking an SV cast after the acquisition of SWMB data to which the cast was intended to be applied. In this event, the cast was manually back-dated so that it would be applied to the SWMB data correctly. Sound velocity profiles for CARIS were concatenated by vessel in order of ascending time/date and saved in the same directory as the individual SVP files for each vessel. A naming convention of *Hxxxxx_vvvv_SVP.SVP* was used where *Hxxxxx* is the sheet's registry number and *vvvv* is the vessel's hull number (Ex: *H11292_1006_SVP.SVP* is the concatenated SVP file for hull number 1006 for sheet H11292). This concatenated file was then applied to all HDCS data collected by that particular vessel with the option **Previous in time** selected under the **Profile Selection Method**.

Vessel Offsets and Dynamic Draft Correctors

The following table shows when the vessel offsets and dynamic draft correctors used for this project were last determined:

Vessel Hull Number	Date of Static Draft and Transducer Offset Measurements	Method of Settlement and Squat Measurement	Date of Settlement and Squat Measurement	Location of Settlement and Squat Measurement
817	May 2004	Rod leveling	April 2003	Fish Bay, AK
1101	March 2004	Surface analysis	March 2004	Lake Washington, WA
1103	March 2004	Surface analysis	March 2004	Lake Washington, WA
1021	March 2004	Surface analysis	March 2004	Lake Washington, WA
1016	March 2004	Surface analysis	March 2004	Lake Washington, WA
1006	March 2004	Surface analysis	March 2004	Lake Washington, WA
1015	March 2004	Surface analysis	March 2004	Lake Washington, WA

Settlement and squat observations were conducted for all launches using a surface analysis method. An area of flat topography was selected in a lake to negate any tidal influence. A line was then run repeatedly in the same direction at different speeds while logging data. Finally data was collected at three pre-selected target areas on the same line while the launch was at rest. Settlement and squat speed curves were derived by querying these target areas using CARIS and graphing the change of apparent depth at different speeds.

Vessel offsets and static draft were measured using both steel tapes and a LEICA laser distance meter. In most cases, measurement values obtained fell close to the historic values and these were retained. In a few cases, the new measurements differed enough from the historic values and the new measurements were carried forward.

New to CARIS HIPS and SIPS version 5.4 is the HIPS Vessel File (HVF) which is intended to eventually replace the CARIS Vessel Configuration File (VCF). To maintain backward compatibility, CARIS retains the ability to use VCFs. The primary difference between these two types of configuration files is the addition of TPE values in the HVFs. RAINIER adopted the use of the HVF file format for all vessels that collected either VBES or SWMB data. Since there is currently no need to model TPE on detached positions (DPs), VCFs were retained for vessel configuration files intended for DPs.

Dynamic draft and vessel offsets corrector values are stored in HVFs. Survey platforms used to collect SWMB data each have a separate HVF associated with each individual acquisition system aboard. The naming format used for each HVF is the hull number followed by type of acquisition system and then "HVF" (ex: 1016_Reson8125_HVF refers to hull #1016 using a Reson 8125 while 1016_Elac1180_HVF refers to the same hull but using the Elac 1180 for data collection instead). Each of these HVFs contain sensor offset and dynamic draft correctors that pertain to this single acquisition system. Sensor offset and dynamic draft correctors were applied to SWMB data in CARIS during post-processing.

Hull numbers 817, 1101 and 1103 are vessels commonly utilized to collect singlebeam data and detached positions. Each of these vessels have three separate configuration files associated with them to cover all possible data collection conditions, HVFs for VBES and VCFs for DPs. The singlebeam acquisition HVFs contain all offset and dynamic draft correctors and are applied only to single beam hydrography. The echosounder VCFs contain all offsets, but exclude the dynamic draft correctors, and are applied to all detached positions which had the height and/or depth determined with an echosounder. Finally the non-echosounder VCFs are simply zeroed out VCFs which are applied to all detached positions where the height and/or depth were determined by some means other than an echosounder, such as visual, sounding pole, lead-line, or divers least depth gauge. Non-echosounder VCFs are also used to mark bottom samples and as such may be associated with any vessel. Detached positions, both echo sounder and non echo sounder, have all sensor offsets applied in Pydro. All single beam data have sensor offsets and dynamic draft applied in CARIS during post-processing.

Vessel offset diagrams and dynamic draft tables are included in Appendix III of this report. The HVFs and VCFs themselves are submitted with the digital HDCS data.

The following table lists each VCF and HVF file used for this project:

VCF or HVF name	Survey Vessel & System Type
1006_NonEchosounder_DP	Jensen hull 1106, detached positions not using echosounder
1006_Reson8101_HVF	Jensen hull 1006, SWMB using hull mounted Reson 8101
1015_Elac1180_HVF	Jensen hull 1015, Hull mounted Elac 1180
1016_Elac1180_HVF	Jensen hull 1016, SWMB using hull mounted Elac 1180
1016_Reson8125_HVF	Jensen hull 1016, SWMB using hull mounted Reson 8125
1021_Reson8101_HVF	Jensen hull 1021, SWMB using swing-arm mounted Reson 8101
1101_Echosounder_DP	Jensen hull 1101, detached positions using echosounder
1101_NonEchosounder_DP	Jensen hull 1101, detached positions not using echosounder
1101_Singlebeam_HVF	Jensen hull 1101, singlebeam using Knudsen 320M
1103_Echosounder_DP	Jensen hull 1103, detached positions using echosounder
1103_NonEchosounder_DP	Jensen hull 1103, detached positions not using echosounder
1103_Singlebeam_HVF	Jensen hull 1103, singlebeam using Knudsen 320M
817_NonEchosounder_DP	SeaArk hull 817, detached positions not using echosounder
817_Ross950_HVF	SeaArk hull 817, singlebeam using Ross 950

Heave, Pitch, Roll and Heading, Including Biases and Navigation Timing Errors

SWMB launches (Vessels 1021, 1016, 1006 and 1015) utilized a TSS POS/MV Model 320 Position and Orientation System – Marine Vessel (POS/MV) which provides accurate navigation and attitude data to correct for the effects of heave, pitch, roll and heading. The POS generates attitude data in three axes (roll, pitch and heading) to an accuracy of 0.05° or better. Heave measurements supplied by the POS/MV maintain an accuracy of 5% of the measured vertical displacement for movements that have a period of up to 20 seconds. The POS/MV delivers heading measurements by two distinct methods. First, the Dynamic Heading Alignment determines the vessels heading by using the data supplied by the Internal Measurement Unit (IMU) and GPS receivers to achieve heading that is, at best, accurate to within 0.25° . This method suffers from drift but is relatively unaffected by noise. Second, the GPS Azimuth Measurement System (GAMS) determines the geographic vector between two GPS antennas fixed to the vessel by comparing the phase of satellite signals they receive. The error from this method is largely due to noise, but exhibits no drift. The POS/MV uses the advantages of each method to compensate for the disadvantages of the other to arrive at an optimal accuracy of 0.05° .

With a series of both software and firmware upgrades in addition to modified wiring, hull 1021 was upgraded for precise timing on March 14th. Launches 1016 and 1006 later had the same upgrade performed over the 4th of July holiday import. The objective of this upgrade is to use a single clock to time stamp all data at the point of acquisition and thus eliminate the latencies introduced by the serial and Ethernet interfaces in addition to the PC millisecond counter. Position, heading and attitude are all time stamped by the POS/MV on UTC epoch and the bathy data is time stamped in SeaBat using the POS/MV UTC serial string. This synchronization essentially eliminates timing errors and variable latencies resulting in data which is both horizontally and vertically more accurate.

Prior to commencement of survey operations, Reson multibeam sonar calibration was conducted. Heave, roll, pitch, and navigation latency lines were run in accordance with section 5.5.1 of the NOS Hydrographic Specifications and Deliverables. Biases were determined in the order navigation timing error, pitch, roll, and finally heading.

Patch test procedures are modified slightly for precise timing. Pitch, roll and yaw lines are collected and processed as usual in accordance with NOS Hydrographic Specifications and Deliverables. Navigation latency is determined by examination of the roll timing error. Roll error can be determined from any single line in an area with relatively flat topography. A thin slice of the outer beams parallel to the line was examined in CARIS calibration mode. Any wavelike pattern observed in the data is assumed to be the result of roll latency. The roll latency value is determined by manually changing the value until the wave pattern disappears. The resultant latency value was also applied to navigation, heave gyro and pitch time errors since they all of these values are produced by the POS/MV.

Elac patch test procedures were modified as outlined in section 3.7.3 of the HydroStar Manuals 2.1. Since the Elac is a beam-steered flat-faced transducer system, the roll bias values must be entered directly into the HydroStar acquisition software for proper beam steering calculations. Roll bias values are not entered into the CARIS HIPS Vessel File (HVF) so as to avoid double application. The transducer alignment option in HydroStar allows for automated computation of the roll bias values based upon two pairs of reciprocal lines in an area with flat seafloor, one offset from the other to ensure an overlap of 100%. Pitch, yaw and navigation latency lines are collected and processed as usual in accordance with NOS Hydrographic Specifications and Deliverables.

All SWMB vessel offsets, dynamic draft correctors, and system bias values (except for Elac roll bias) are contained in HVFs and were created using the program Vessel Editor in CARIS. These offsets and biases are applied to the sounding data during processing in CARIS. All applicable HVFs are included with the digital HDCS data.

Water Level Correctors

Soundings were reduced to Mean Lower-Low Water (MLLW) using unverified observed tide data for station Valdez, AK (945-4240). Tide data were obtained from the Center for Operational Oceanographic Products and Services (CO-OPS) web site through TideBot. These data were used in creating the observed tide corrector tables (*.tid files) in CARIS. Raw observed water level data from this reference stations were applied to the survey depths in CARIS using height ratio and time correctors from the CO-OPS provided zone definition file (*.zdf).

Refer to the Horizontal and Vertical Control Report for specific information on the tidal gauges used in during this project and individual Descriptive Reports for further information regarding water level correctors specific to each survey.

D. APPROVAL

As Chief of Party, I have ensured that standard field surveying and processing procedures were used during this project in accordance with the Hydrographic Manual, Fourth Edition; Hydrographic Survey Guidelines; Field Procedures Manual, and the NOS Hydrographic Surveys Specifications and Deliverables Manual, as updated for 2003.

I acknowledge that all of the information contained in this report is complete and accurate to the best of my knowledge.

Approved and Forwarded:

John W. Humphrey
Commander, NOAA
Commanding Officer

In addition, the following individual was also responsible for overseeing data acquisition and processing of this project:

Field Operations Officer:

Kevin J. Slover
Lieutenant, NOAA

Chief Survey Technician:

James B. Jacobson
Chief Survey Technician, NOAA

APPENDIX I

Software Versions and Hardware Serial Numbers

Software Versions

		version	service pack	hot fix	other	date	comments
Acquisition	Hypack Max	02.12a			build 2.12.52.0	3/15/04	
	POS/MV controller v2	3.0				3/15/04	
	POS/MV controller v3	2.1				3/15/04	
	Isis	6.41 6.5				3/14/04 3/14/04 7/1/04	1021 only 1016 & 1006
	Hydostar	3.4.0.1				3/15/04	
	Sonar Pro (for Klein 3000)	6.4				3/15/04	
Processing	CARIS GIS	4.4a	3 4	10 11-29 1-8 9-10 11-14 15 16-17 18-19 20-21 22-24		3/15/04 4/22/04 8/2/04 9/27/04 10/18/04 10/25/04 11/15/04 12/3/04 12/20/04 1/18/05	
	-HIPS/SIPS	5.3 5.4	3 1	25 1-7 7-12 13-14 1-2 3-5 6-8 9-10 11 12 13 14 15-16 17 18-19 20 21	Elac SV patch XTF converter patch Elac imagery patch	3/11/04 4/8/04 4/9/04 4/20/04 5/27/04 6/1/04 6/14/04 6/26/04 8/2/04 8/4/04 9/16/04 9/27/04 10/4/04 10/6/04 10/13/04 10/25/04 11/15/04 12/3/04 12/10/04 12/20/04 1/12/05	2-part install for Reson 8125 fixes backscatter 2 computers only
	Pydro	3.7.1 4.4.1 4.4.4 4.6.1 4.7.1 4.9.0 4.9.1 4.9.2 4.9.3					4/9/04 5/9/04 7/22/04 8/2/04 9/27/04 10/18/04 10/28/04 11/5/04

Processing	Python	2.2.2 2.3.3				3/15/04 4/9/04	for new Pydro
	wxPython	2.4.0.7 2.4.2.4				3/15/04 4/9/04	for new Pydro
	HP Tools	3.7.3 3.8.1				3/15/04 4/9/04	
	KapConv	3.9.1				3/15/04	
	NOAA Chart Reprojector	2.0.2a				3/15/04	
	MapInfo	6.5			build 19	3/15/04	
	Vertical Mapper	3.0			build 3.0.0.019	3/15/04	
	Fledermaus	5.1.2 6.1.0				3/15/04 5/13/04	Windows ver.
	Exceed	7.1.1				3/15/04	for Fledermaus
Horizontal Control	TSIP Talker	2.00				3/15/04	
	DSX/National Geodetic Society DSData Extraction	6.04				3/15/04	
	GPPS/Geodetic Post Processing Software	5.0.00				3/15/04 3/15/04	
	Ashtech Mission Planner	4.50				3/15/04	
	Fillnet	3.1				3/15/04	
Vertical Control	Sound Velocity						
	VelocWin	8.4				3/15/04	
	SBE SeaTerm	1.3				3/15/04	
	Leveling						
	Newiz	2.0				3/15/04	for PocketPC
	Tides						
	LogPlot	1.4				3/15/04	
LogStats	1.1				3/15/04		
LogPrn Convert	1.9				3/15/04	2 to 4 digit year	
Utilities	Tides and Currents	2.5b				3/15/04	
	Winzip	9				3/15/04	large file support

Description	Vessel	Serial Number
Knudsen Engineering Limited 320M Marine Echosounders	Spare	K96388
	1101	K99323
	1103	K98579
	1021	none aboard
	1016	K99322
	1006	K96387
	1015	K99324
RESON 8101 SONAR Processor	1021	17005
	1006	31676
RESON Seabat 81-P Sonar Processor (for 8125)	1016	29979
Seabeam/Elac 1180	1015	76
	1016	77
	S221	62
Trimble DSM212L	Spare	0220157914
	1101	0220159717
	1103	0220159719
	S221	0220157923
csi Wireless MBX-3S	1021	0324-11969-0002
Trimble ProBeacon	1016	0220238661
	1006	0220242435
	1015	0220238662
	S221	0220238648
TSS Position & Orientation System POS/MV V2	1015	021
TSS Position & Orientation System POS/MV V3	1021	507
	1016	295
	1006	304
TSS IMU	1021	305
	1016	131
	1006	28
	1015	37
Digibar Pro	1016	98015
	1015	98016
TSS/MAHRS	S221	003008

APPENDIX II

Data Processing Flow Diagrams

Raw sounding data to HDCS

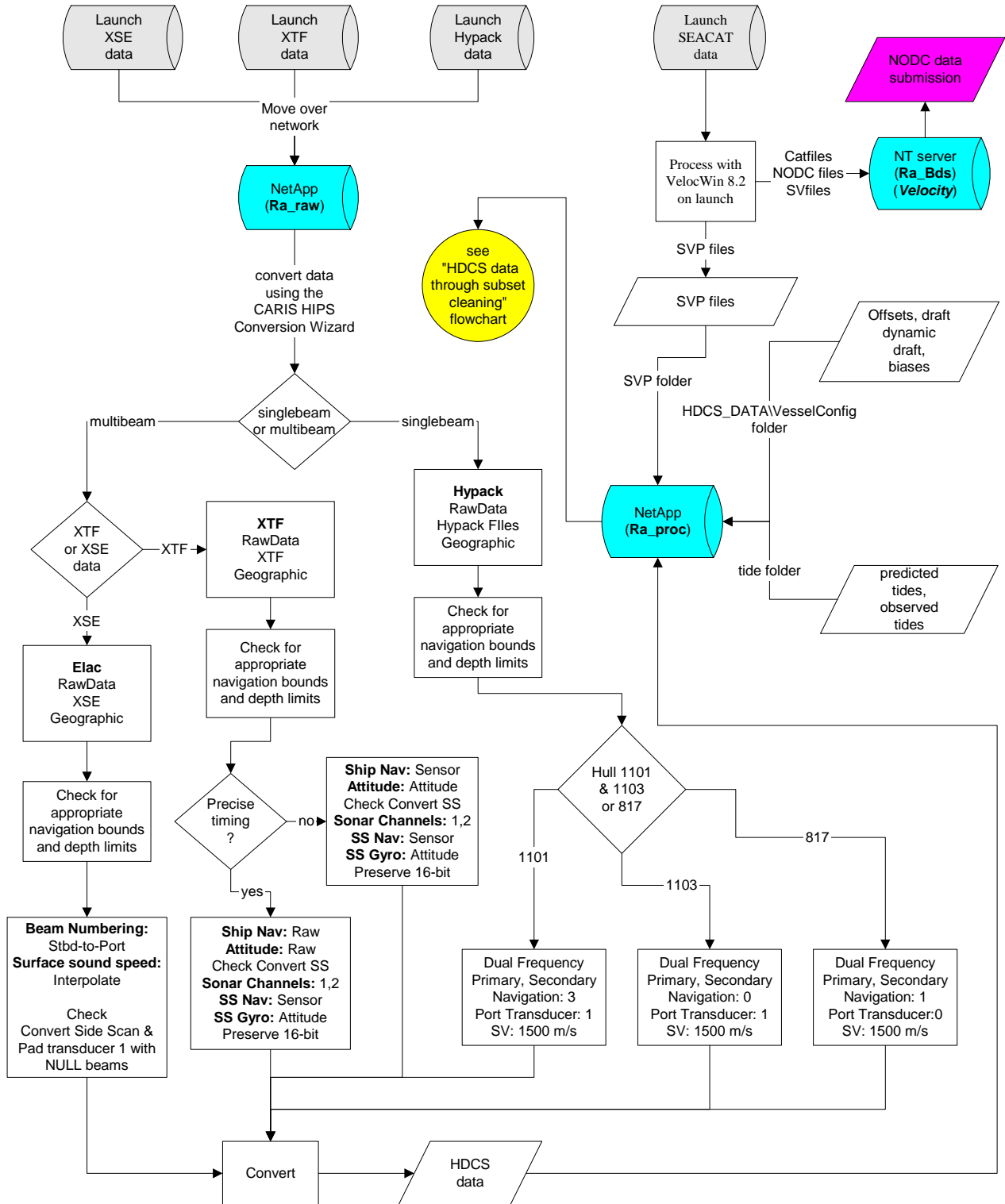

Detached Position processing (Raw DP's to Pydro)

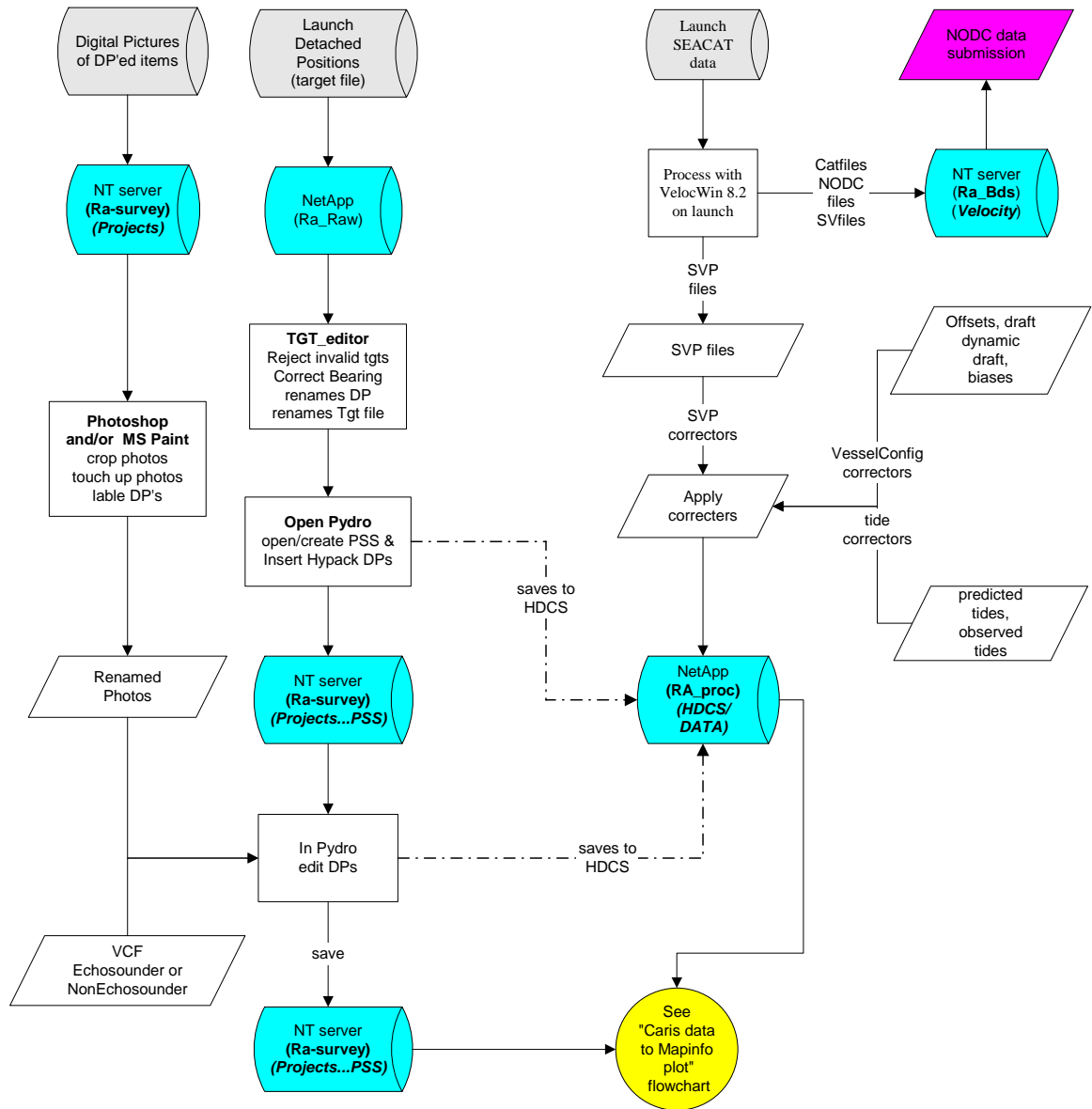

Detached Position processing in Pydro

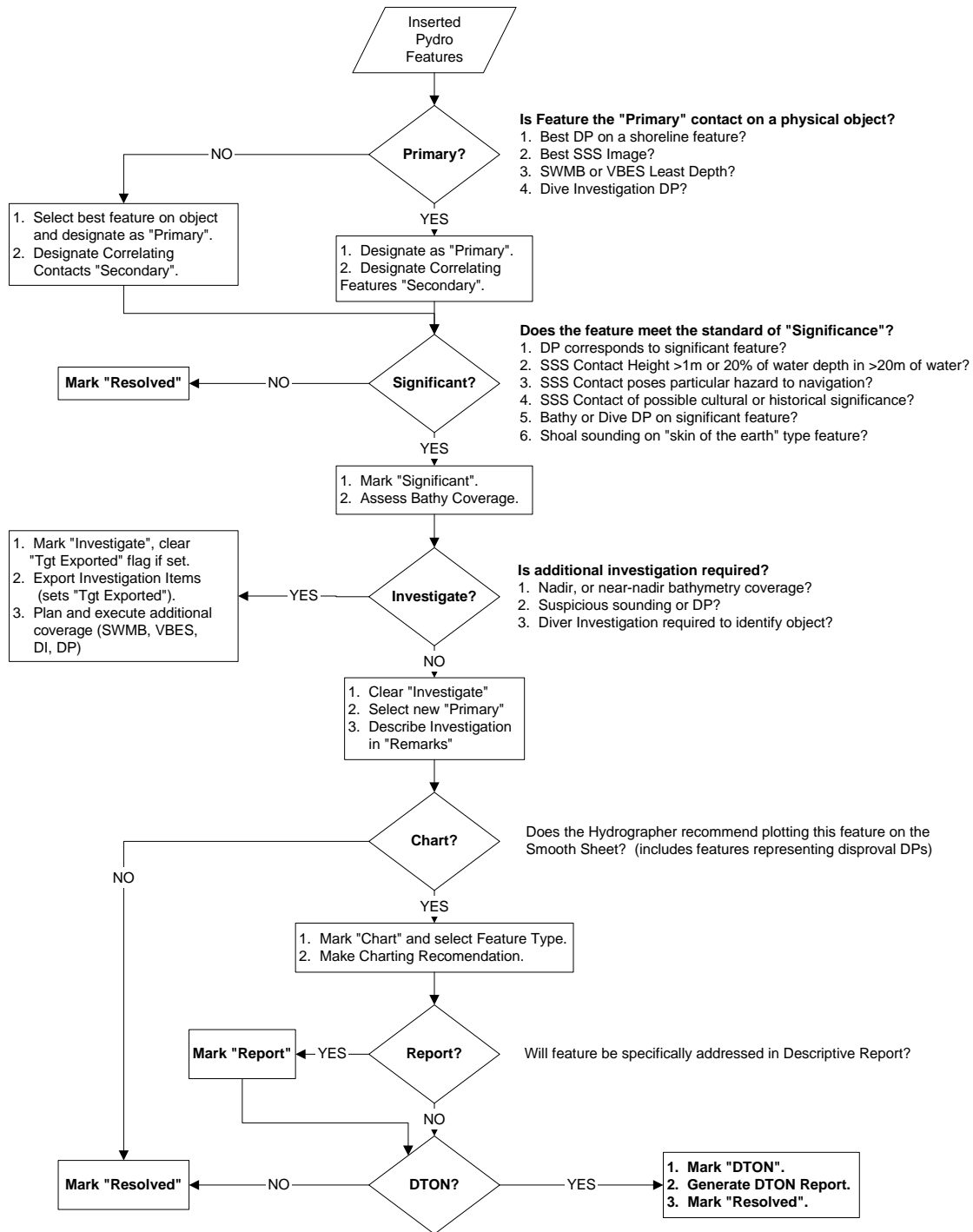

HDCS data through subset cleaning

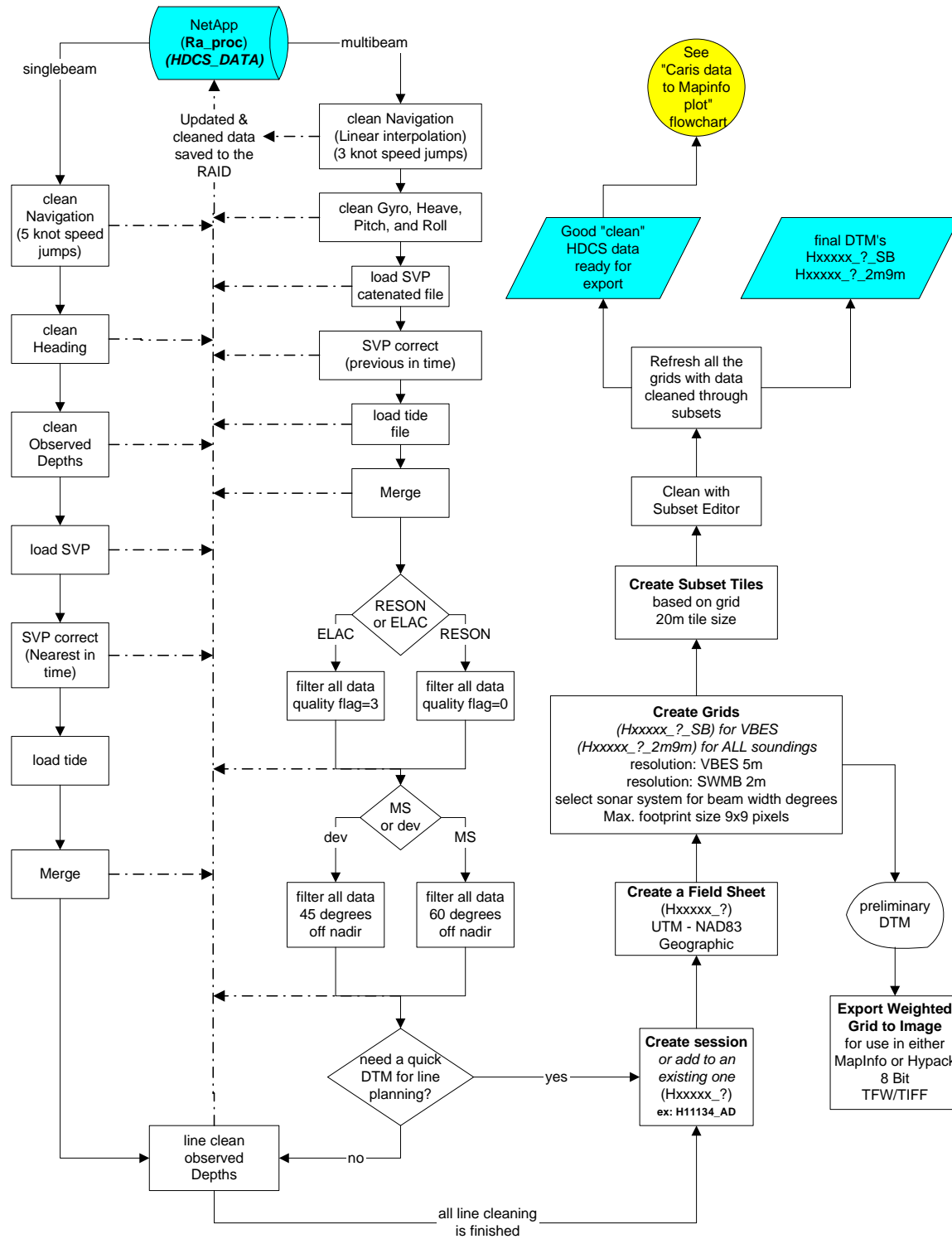

Caris data to MapInfo plot

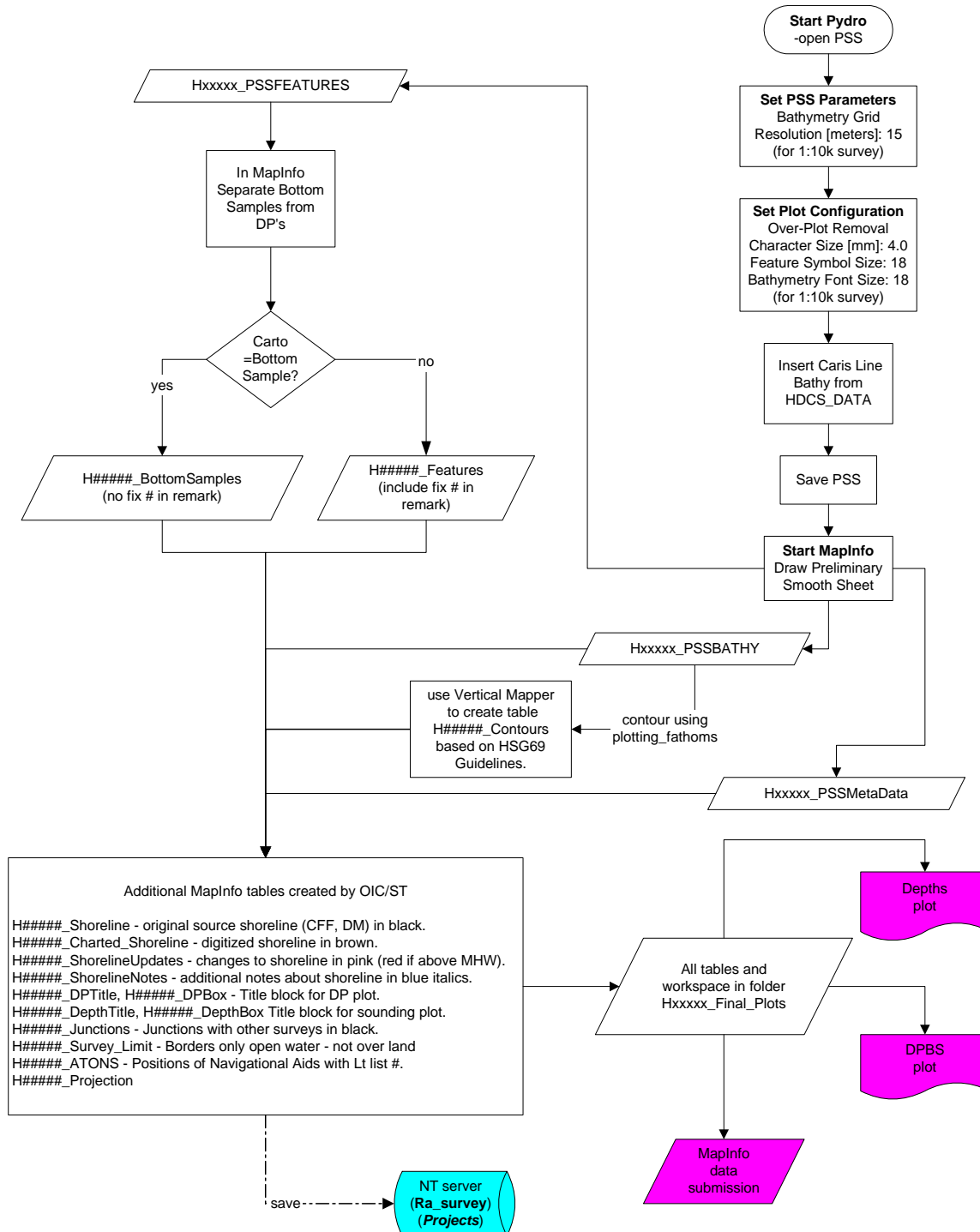

APPENDIX III

Vessel Offset Diagrams CARIS Vessel Reports

CARIS Offset Sign Conventions

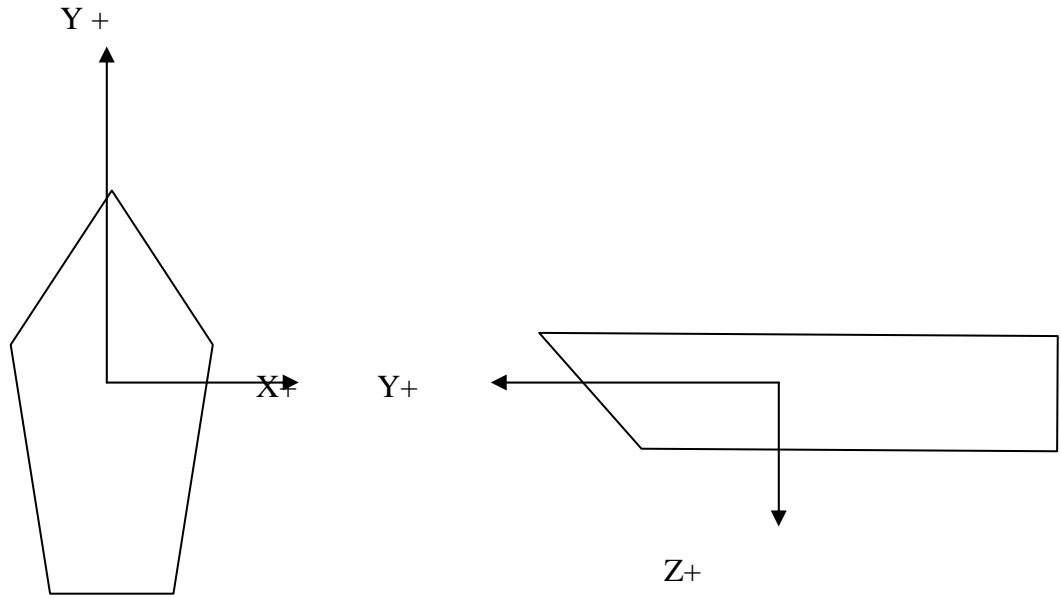

Hull 1101 (RA1) Vessel Offset Measurements

10/15/2004

Description: Aluminum Jensen survey launch, jet drive

LOA: 29 feet

Weigh: 14,000 lbs

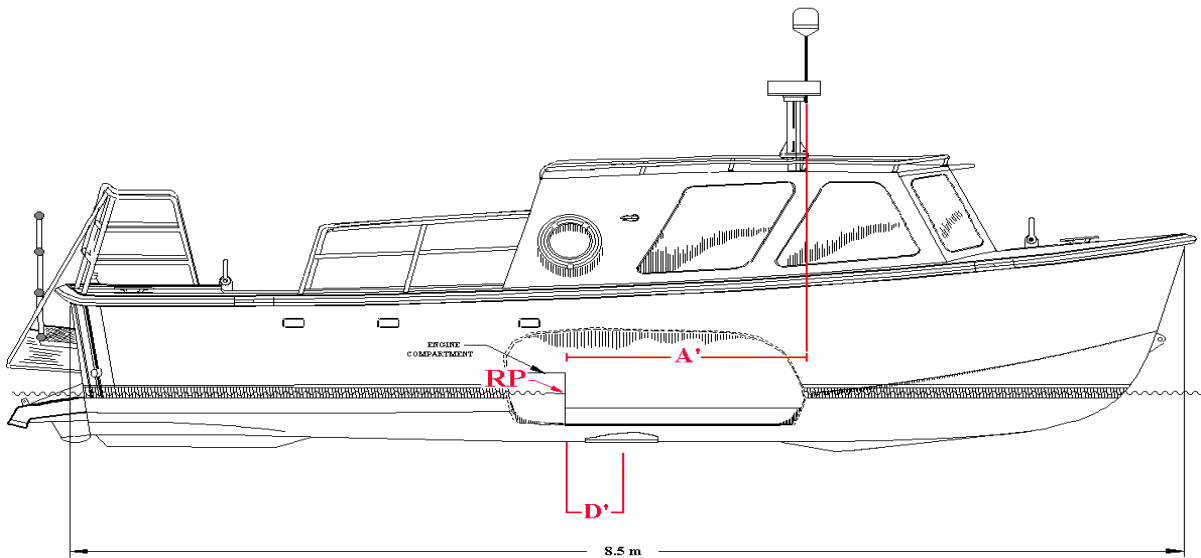

* Assume RP at waterline & centerline of engine bulkhead

		Y (along-ship)	
		cm.	date measured
RP to GPS	A'	180.0	3/21/01
RP to VBES transducer	D'	45.5	3/21/01

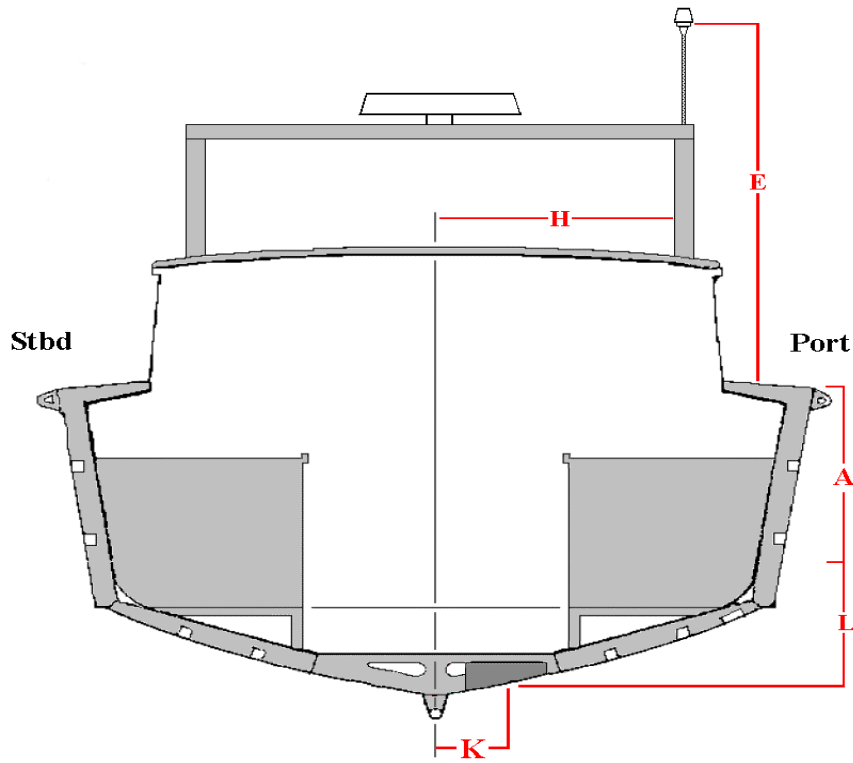

		X (athwartship)		Z (vertical)	
		cm.	date measured	cm.	date measured
Waterline to deck	A	n/a	n/a	101.0	3/21/01
Deck to bottom of GPS	E	n/a	n/a	254.0	3/21/01
Waterline to VBES transducer	L	n/a	n/a	43.0	3/21/01
Centerline to GPS	H	81.0	3/21/01	n/a	n/a
Centerline to VBES transducer	K	26.0	3/21/01	n/a	n/a

CARIS configuration is based on a Reference Position (RP)
 RP is assumed to be centerline, at the waterline, on the forward side
 of the bulkhead separating the engine compartment from the cabin

X athwartship distance [+ starboard]
Y along-ship distance [+ towards bow]
Z vertical distance [+ into water]

X	RP to VBES transducer (equals K)	-0.26	Singlebeam
	RP to GPS (equals H)	-0.81	Navigation
Y	RP to VBES transducer (equals D')	0.46	
	RP to GPS (equals A')	1.80	
Z	RP to VBES transducer (equals L)	0.43	
	RP to GPS (equals A + E)	-3.55	

Vessel Name: 1101_Echosounder_DP
Vessel created: August 24, 2004

Depth Sensor:

Sensor Class: Swath
Time Stamp: 2002-001 00:00

Transducer #1:

Pitch Offset: 0.000
Roll Offset: 0.000
Azimuth Offset: 0.000

DeltaX: -0.260
DeltaY: 0.460
DeltaZ: 0.430

Manufacturer:
Model: Unknown
Serial Number:

Navigation Sensor:

Time Stamp: 2002-001 00:00

Comments
Latency 0.000
DeltaX: -0.810
DeltaY: 1.800
DeltaZ: -3.550

Manufacturer: (null)
Model: (null)
Serial Number: (null)

Gyro Sensor:

Time Stamp: 2002-001 00:00

Comments
Latency 0.000

Entry 0) Draft: 0.000 Speed: 0.000

Heave Sensor:

Time Stamp: 2002-001 00:00

Comments
Apply No
Latency 0.000
DeltaX: 0.000

DeltaY: 0.000

DeltaZ: 0.000

Manufacturer: (null)

Model: (null)

Serial Number: (null)

Time Stamp: 2002-001 00:01

Comments

Apply No

Latency 0.000

DeltaX: 0.000

DeltaY: 0.000

DeltaZ: 0.000

Manufacturer: (null)

Model: (null)

Serial Number: (null)

Pitch Sensor:

Time Stamp: 2002-001 00:00

Comments

Apply No

Latency 0.000

Pitch offset: 0.000

Manufacturer: (null)

Model: (null)

Serial Number: (null)

Time Stamp: 2002-001 00:01

Comments

Apply No

Latency 0.000

Pitch offset: 0.000

Manufacturer: (null)

Model: (null)

Serial Number: (null)

Roll Sensor:

Time Stamp: 2002-001 00:00

Comments

Apply No

Latency 0.000

Roll offset: 0.000

Manufacturer: (null)

Model: (null)

Serial Number: (null)

Time Stamp: 2002-001 00:01

Comments
Apply No
Latency 0.000
Roll offset: 0.000

Manufacturer: (null)
Model: (null)
Serial Number: (null)

Draft Sensor:

Time Stamp: 2002-001 00:00

Apply Yes
Comments
Entry 1) Draft: 0.000 Speed: 0.000
Entry 2) Draft: 0.000 Speed: 1.700
Entry 3) Draft: 0.000 Speed: 3.700
Entry 4) Draft: 0.000 Speed: 4.800
Entry 5) Draft: 0.000 Speed: 5.600
Entry 6) Draft: 0.000 Speed: 6.700
Entry 7) Draft: 0.000 Speed: 7.200
Entry 8) Draft: 0.000 Speed: 8.400
Entry 9) Draft: 0.000 Speed: 9.300
Entry 10) Draft: 0.000 Speed: 17.100

Tow Point:

Time Stamp: 2003-091 00:00

Comments
Latency 0.000
DeltaX: 0.900
DeltaY: -4.390
DeltaZ: -3.260

Manufacturer: (null)
Model: (null)
Serial Number: (null)

Svp Sensor:

Time Stamp: 2002-001 00:00

Comments
Svp #1:

Pitch Offset: 0.000
Roll Offset: 0.000
Azimuth Offset: 0.000

DeltaX: 0.000

DeltaY: 0.000

DeltaZ: 0.000

SVP #2:

Pitch Offset: 0.000

Roll Offset: 0.000

Azimuth Offset: 0.000

DeltaX: -0.260

DeltaY: 0.460

DeltaZ: 0.430

WaterLine:

Time Stamp: 2002-001 00:00

Comments

Apply Yes

WaterLine 0.000

WaterLineStdDev 0.000

Vessel Name: 1101_NonEchosounder_DP
Vessel created: August 24, 2004

Depth Sensor:

Sensor Class: Swath
Time Stamp: 2003-112 00:00

Transducer #1:

Pitch Offset: 0.000
Roll Offset: 0.000
Azimuth Offset: 0.000

DeltaX: 0.000
DeltaY: 0.000
DeltaZ: 0.000

Manufacturer:
Model: Unknown
Serial Number:

Navigation Sensor:

Time Stamp: 2003-112 00:00

Comments
Latency 0.000
DeltaX: 0.000
DeltaY: 0.000
DeltaZ: 0.000

Manufacturer: (null)
Model: (null)
Serial Number: (null)

Vessel Name: 1101_Singlebeam_HVF.hvf
Vessel created: August 23, 2004

Depth Sensor:

Sensor Class: Swath
 Time Stamp: 2002-001 00:00

Transducer #1:

Pitch Offset: 0.000
 Roll Offset: 0.000
 Azimuth Offset: 0.000

DeltaX: -0.260
 DeltaY: 0.460
 DeltaZ: 0.430

Manufacturer: knudson
 Model: kn320m
 Serial Number:

Navigation Sensor:

Time Stamp: 2002-001 00:00

Comments
 Latency 0.000
 DeltaX: -0.810
 DeltaY: 1.800
 DeltaZ: -3.550

Manufacturer: (null)
 Model: (null)
 Serial Number: (null)

Gyro Sensor:

Time Stamp: 2002-001 00:00

Comments
 Latency 0.000

Entry 0) Draft: 0.000 Speed: 0.000

Heave Sensor:

Time Stamp: 2002-001 00:00

Comments
 Apply No
 Latency 0.000
 DeltaX: 0.000
 DeltaY: 0.000
 DeltaZ: 0.000

Manufacturer: (null)
 Model: (null)
 Serial Number: (null)

Time Stamp: 2002-001 00:01

Comments
 Apply No
 Latency 0.000
 DeltaX: 0.000
 DeltaY: 0.000
 DeltaZ: 0.000

Manufacturer: (null)
 Model: (null)
 Serial Number: (null)

Pitch Sensor:

Time Stamp: 2002-001 00:00

Comments
 Apply No
 Latency 0.000
 Pitch offset: 0.000

Manufacturer: (null)
 Model: (null)
 Serial Number: (null)

Time Stamp: 2002-001 00:01

Comments
 Apply No
 Latency 0.000
 Pitch offset: 0.000

Manufacturer: (null)
 Model: (null)
 Serial Number: (null)

Roll Sensor:

Time Stamp: 2002-001 00:00

Comments
 Apply No
 Latency 0.000
 Roll offset: 0.000

Manufacturer: (null)
 Model: (null)
 Serial Number: (null)

Time Stamp: 2002-001 00:01

Comments
 Apply No
 Latency 0.000
 Roll offset: 0.000

Manufacturer: (null)
 Model: (null)
 Serial Number: (null)

Draft Sensor:

Time Stamp: 2002-001 00:00

Apply Yes
 Comments
 Entry 1) Draft: 0.000 Speed: 0.000
 Entry 2) Draft: -0.010 Speed: 1.700
 Entry 3) Draft: -0.020 Speed: 3.700
 Entry 4) Draft: -0.010 Speed: 4.800
 Entry 5) Draft: 0.010 Speed: 5.600
 Entry 6) Draft: 0.040 Speed: 6.700
 Entry 7) Draft: 0.050 Speed: 7.200
 Entry 8) Draft: 0.060 Speed: 8.400
 Entry 9) Draft: 0.000 Speed: 9.300
 Entry 10) Draft: -0.260 Speed: 17.100

Tow Point:

Time Stamp: 2003-091 00:00

Comments
 Latency 0.000
 DeltaX: 0.900
 DeltaY: -4.390
 DeltaZ: -3.260

Manufacturer: (null)
 Model: (null)
 Serial Number: (null)

TPE

Time Stamp: 2004-235 15:00

Comments S.Allen
 Offsets

Motion sensing unit to the transducer 1
 X Head 1 0.000
 Y Head 1 0.000
 Z Head 1 0.000
 Motion sensing unit to the transducer 2
 X Head 2 0.000
 Y Head 2 0.000

Z Head 2 0.000
 Navigation antenna to the transducer 1
 X Head 1 0.550
 Y Head 1 -1.345
 Z Head 1 3.980
 Navigation antenna to the transducer 2
 X Head 2 0.000
 Y Head 2 0.000
 Z Head 2 0.000

Roll offset of transducer number 1 0.000
 Roll offset of transducer number 2 0.000

Heave Error: 0.000 or 0.000" of heave amplitude.
 Measurement errors: 0.020
 Motion sensing unit alignment errors
 Gyro:0.000 Pitch:0.000 Roll:0.000
 Gyro measurement error: 0.000
 Roll measurement error: 0.000
 Pitch measurement error: 0.000
 Navigation measurement error: 0.700
 Transducer timing error: 0.000
 Navigation timing error: 0.000
 Gyro timing error: 0.000
 Heave timing error: 0.000
 PitchTimingStdDev: 0.000
 Roll timing error: 0.000
 Sound Velocity speed measurement error: 0.500
 Surface sound speed measurement error: 0.000
 Tide measurement error: 0.010
 Tide zoning error: 0.200
 Speed over ground measurement error: 0.030
 Dynamic loading measurement error: 0.030
 Static draft measurement error: 0.050
 Delta draft measurement error: 0.010

Svp Sensor:

Time Stamp: 2002-001 00:00

Comments

Svp #1:

Pitch Offset: 0.000
 Roll Offset: 0.000
 Azimuth Offset: 0.000

DeltaX: 0.000
 DeltaY: 0.000
 DeltaZ: 0.000

SVP #2:

Pitch Offset: 0.000
 Roll Offset: 0.000
 Azimuth Offset: 0.000

DeltaX: -0.260
 DeltaY: 0.460

DeltaZ: 0.430

WaterLine:

Time Stamp: 2002-001 00:00

Comments

Apply Yes

WaterLine 0.000

WaterLineStdDev 0.000

Hull 1103 (RA2) Vessel Offset Measurements

10/15/2004

Description: Munson aluminum work boat, jet drive

LOA: 28 feet

Weigh: 10,200 lbs

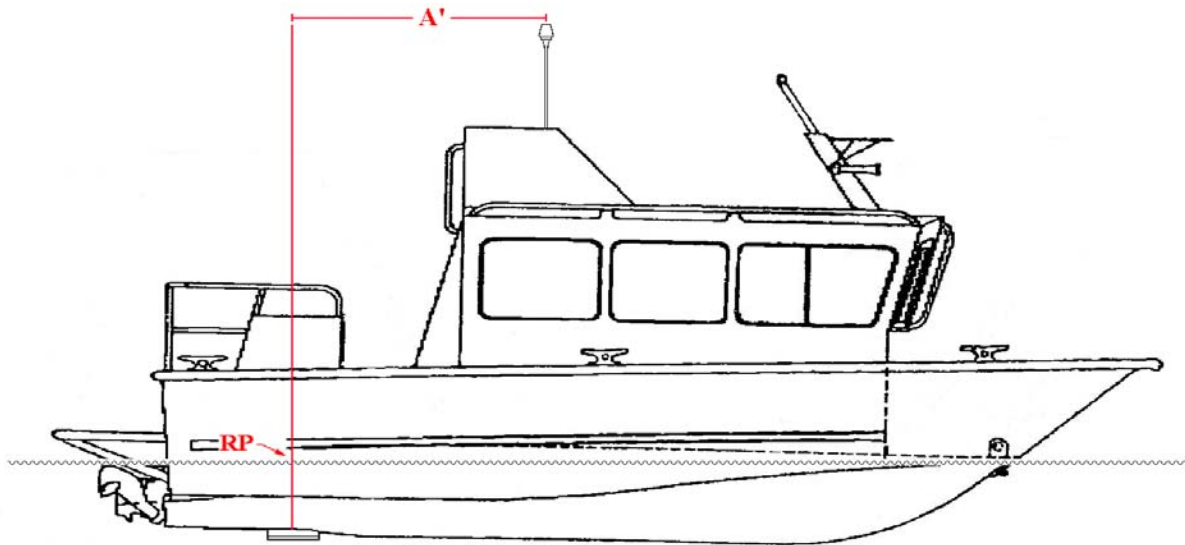

		Y (along-ship)	
		cm.	date measured
RP to GPS	A'	196.0	Mar-98
RP to VBES transducer		0.0	n/a

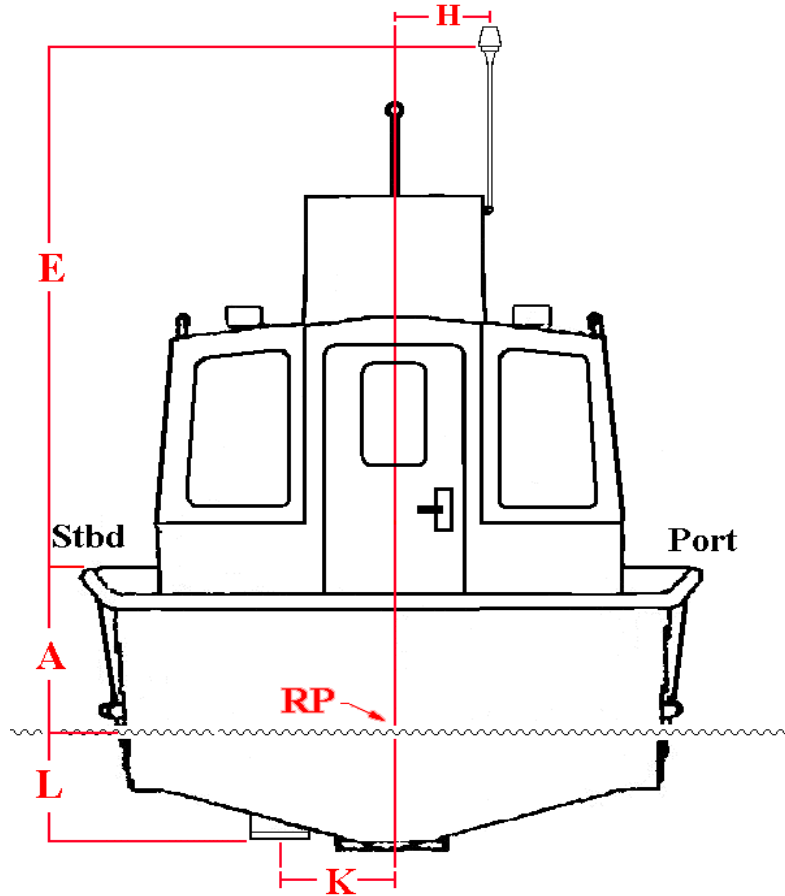

		X (athwartship)		Z (vertical)	
		cm.	date measured	cm.	date measured
Waterline to deck	A	n/a	n/a	87.5	Mar-98
Deck to bottom of GPS	E	n/a	n/a	265.0	May-00
Waterline to VBES transducer	L	n/a	n/a	53.0	Mar-98
Centerline to GPS	H	49.0	May-00	n/a	n/a
Centerline to VBES transducer	K	62.0	May-00	n/a	n/a

CARIS configuration is based on a Reference Position (RP)
 In RA-2 the RP is assumed to be centerline, at the waterline,
 above the transducer

X athwartship distance [+ starboard]
Y along-ship distance [+ towards bow]
Z vertical distance [+ into water]

X	RP to VBES transducer (equals K)	0.62	Singlebeam
	RP to GPS (equals H)	-0.49	
Y	RP to VBES transducer (equals D')	0.00	Navigation
	RP to GPS (equals A')	1.96	
Z	RP to VBES transducer (equals L)	0.53	
	RP to GPS (equals A + E)	-3.53	

Vessel Name: 1103_Echosounder_DP
Vessel created: August 24, 2004

Depth Sensor:

Sensor Class: Swath
 Time Stamp: 2003-110 00:00

Transducer #1:

 Pitch Offset: 0.000
 Roll Offset: 0.000
 Azimuth Offset: 0.000

DeltaX: 0.620
 DeltaY: 0.000
 DeltaZ: 0.530

Manufacturer: Knudsen
 Model: 320M
 Serial Number:

Navigation Sensor:

Time Stamp: 2003-110 00:00

Comments
 Latency 0.000
 DeltaX: -0.490
 DeltaY: 1.960
 DeltaZ: -3.530

Manufacturer: (null)
 Model: (null)
 Serial Number: (null)

Draft Sensor:

Time Stamp: 2003-110 00:00

Apply Yes
 Comments

Entry 1) Draft: 0.000	Speed: 0.000
Entry 2) Draft: 0.000	Speed: 2.500
Entry 3) Draft: 0.000	Speed: 4.600
Entry 4) Draft: 0.000	Speed: 5.800
Entry 5) Draft: 0.000	Speed: 6.400
Entry 6) Draft: 0.000	Speed: 7.000
Entry 7) Draft: 0.000	Speed: 7.600
Entry 8) Draft: 0.000	Speed: 8.400
Entry 9) Draft: 0.000	Speed: 9.400
Entry 10) Draft: 0.000	Speed: 11.000

Svp Sensor:

Time Stamp: 2003-110 00:00

Comments

Svp #1:

Pitch Offset: 0.000

Roll Offset: 0.000

Azimuth Offset: 0.000

DeltaX: 0.000

DeltaY: 0.000

DeltaZ: 0.000

SVP #2:

Pitch Offset: 0.000

Roll Offset: 0.000

Azimuth Offset: 0.000

DeltaX: 0.620

DeltaY: 0.000

DeltaZ: 0.530

WaterLine:

Time Stamp: 2003-110 00:00

Comments

Apply Yes

WaterLine 0.000

WaterLineStdDev 0.000

Vessel Name: 1103_NonEchosounder_DP
Vessel created: August 24, 2004

Depth Sensor:

Sensor Class: Swath
Time Stamp: 2003-112 00:00

Transducer #1:

Pitch Offset: 0.000
Roll Offset: 0.000
Azimuth Offset: 0.000

DeltaX: 0.000
DeltaY: 0.000
DeltaZ: 0.000

Manufacturer:
Model: Unknown
Serial Number:

Navigation Sensor:

Time Stamp: 2003-112 00:00

Comments
Latency 0.000
DeltaX: 0.000
DeltaY: 0.000
DeltaZ: 0.000

Manufacturer: (null)
Model: (null)
Serial Number: (null)

Vessel Name: 1103_Singlebeam_HVF.hvf
Vessel created: August 22, 2004

Depth Sensor:

Sensor Class: Swath
Time Stamp: 2002-001 00:00

Transducer #1:

Pitch Offset: 0.000
Roll Offset: 0.000
Azimuth Offset: 0.000

DeltaX: -0.260
DeltaY: 0.460
DeltaZ: 0.430

Manufacturer: knudson
Model: kn320m
Serial Number:

Navigation Sensor:

Time Stamp: 2002-001 00:00

Comments
Latency 0.000
DeltaX: -0.810
DeltaY: 1.800
DeltaZ: -3.550

Manufacturer: (null)
Model: (null)
Serial Number: (null)

Gyro Sensor:

Time Stamp: 2002-001 00:00

Comments
Latency 0.000

Entry 0) Draft: 0.000 Speed: 0.000

Heave Sensor:

Time Stamp: 2002-001 00:00

Comments
Apply No
Latency 0.000
DeltaX: 0.000
DeltaY: 0.000
DeltaZ: 0.000

Manufacturer: (null)
 Model: (null)
 Serial Number: (null)

Time Stamp: 2002-001 00:01

Comments
 Apply No
 Latency 0.000
 DeltaX: 0.000
 DeltaY: 0.000
 DeltaZ: 0.000

Manufacturer: (null)
 Model: (null)
 Serial Number: (null)

Pitch Sensor:

Time Stamp: 2002-001 00:00

Comments
 Apply No
 Latency 0.000
 Pitch offset: 0.000

Manufacturer: (null)
 Model: (null)
 Serial Number: (null)

Time Stamp: 2002-001 00:01

Comments
 Apply No
 Latency 0.000
 Pitch offset: 0.000

Manufacturer: (null)
 Model: (null)
 Serial Number: (null)

Roll Sensor:

Time Stamp: 2002-001 00:00

Comments
 Apply No
 Latency 0.000
 Roll offset: 0.000

Manufacturer: (null)
 Model: (null)
 Serial Number: (null)

Time Stamp: 2002-001 00:01

Comments
 Apply No
 Latency 0.000
 Roll offset: 0.000

Manufacturer: (null)
 Model: (null)
 Serial Number: (null)

Draft Sensor:

Time Stamp: 2002-001 00:00

Apply Yes
 Comments
 Entry 1) Draft: 0.000 Speed: 0.000
 Entry 2) Draft: -0.010 Speed: 1.700
 Entry 3) Draft: -0.020 Speed: 3.700
 Entry 4) Draft: -0.010 Speed: 4.800
 Entry 5) Draft: 0.010 Speed: 5.600
 Entry 6) Draft: 0.040 Speed: 6.700
 Entry 7) Draft: 0.050 Speed: 7.200
 Entry 8) Draft: 0.060 Speed: 8.400
 Entry 9) Draft: 0.000 Speed: 9.300
 Entry 10) Draft: -0.260 Speed: 17.100

Tow Point:

Time Stamp: 2003-091 00:00

Comments
 Latency 0.000
 DeltaX: 0.900
 DeltaY: -4.390
 DeltaZ: -3.260

Manufacturer: (null)
 Model: (null)
 Serial Number: (null)

TPE

Time Stamp: 2004-235 15:00

Comments S.Allen
 Offsets

Motion sensing unit to the transducer 1
 X Head 1 0.000
 Y Head 1 0.000
 Z Head 1 0.000
 Motion sensing unit to the transducer 2
 X Head 2 0.000
 Y Head 2 0.000

Z Head 2 0.000
 Navigation antenna to the transducer 1
 X Head 1 1.110
 Y Head 1 1.960
 Z Head 1 4.055
 Navigation antenna to the transducer 2
 X Head 2 0.000
 Y Head 2 0.000
 Z Head 2 0.000

Roll offset of transducer number 1 0.000
 Roll offset of transducer number 2 0.000

Heave Error: 0.000 or 0.000" of heave amplitude.
 Measurement errors: 0.020
 Motion sensing unit alignment errors
 Gyro:0.000 Pitch:0.000 Roll:0.000
 Gyro measurement error: 0.000
 Roll measurement error: 0.000
 Pitch measurement error: 0.000
 Navigation measurement error: 0.700
 Transducer timing error: 0.000
 Navigation timing error: 0.000
 Gyro timing error: 0.000
 Heave timing error: 0.000
 PitchTimingStdDev: 0.000
 Roll timing error: 0.000
 Sound Velocity speed measurement error: 0.500
 Surface sound speed measurement error: 0.000
 Tide measurement error: 0.010
 Tide zoning error: 0.200
 Speed over ground measurement error: 0.030
 Dynamic loading measurement error: 0.030
 Static draft measurement error: 0.050
 Delta draft measurement error: 0.010

Svp Sensor:

Time Stamp: 2002-001 00:00

Comments

Svp #1:

Pitch Offset: 0.000
 Roll Offset: 0.000
 Azimuth Offset: 0.000

DeltaX: 0.000
 DeltaY: 0.000
 DeltaZ: 0.000

SVP #2:

Pitch Offset: 0.000
 Roll Offset: 0.000
 Azimuth Offset: 0.000

DeltaX: -0.260
 DeltaY: 0.460

DeltaZ: 0.430

WaterLine:

Time Stamp: 2002-001 00:00

Comments

Apply Yes

WaterLine 0.000

WaterLineStdDev 0.000

Hull 1021 (RA3) Vessel Offset Measurements

7/10/2004

Description: Aluminum Jensen survey launch

LOA: 29 feet

Weigh: 14,000 lbs

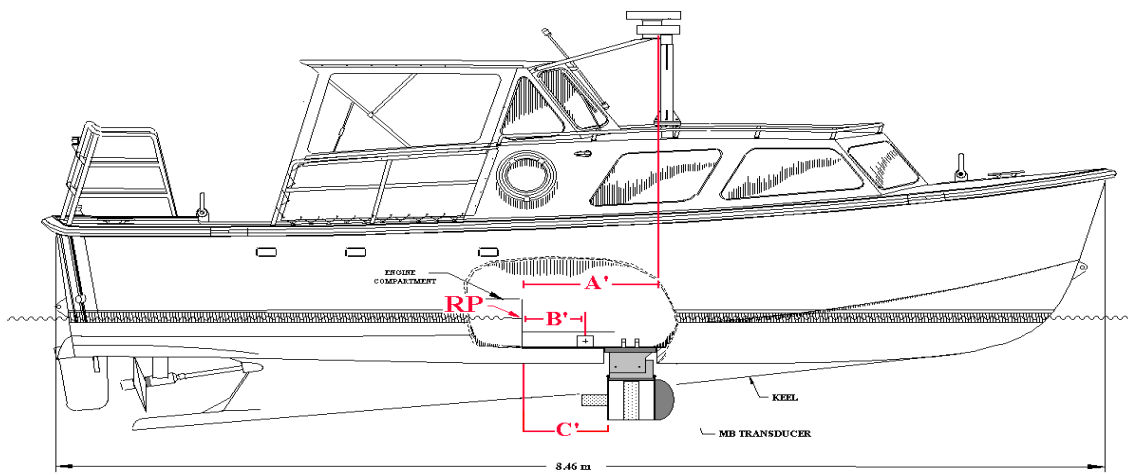

* Assume RP at waterline & centerline of engine bulkhead

		Y (along-ship)	
		date	
		cm.	measured
RP to GPS	A'	85.0	Mar-04
RP to MRU	B'	49.0	Mar-04
RP to SWMB ducer	C'	34.4	Mar-04

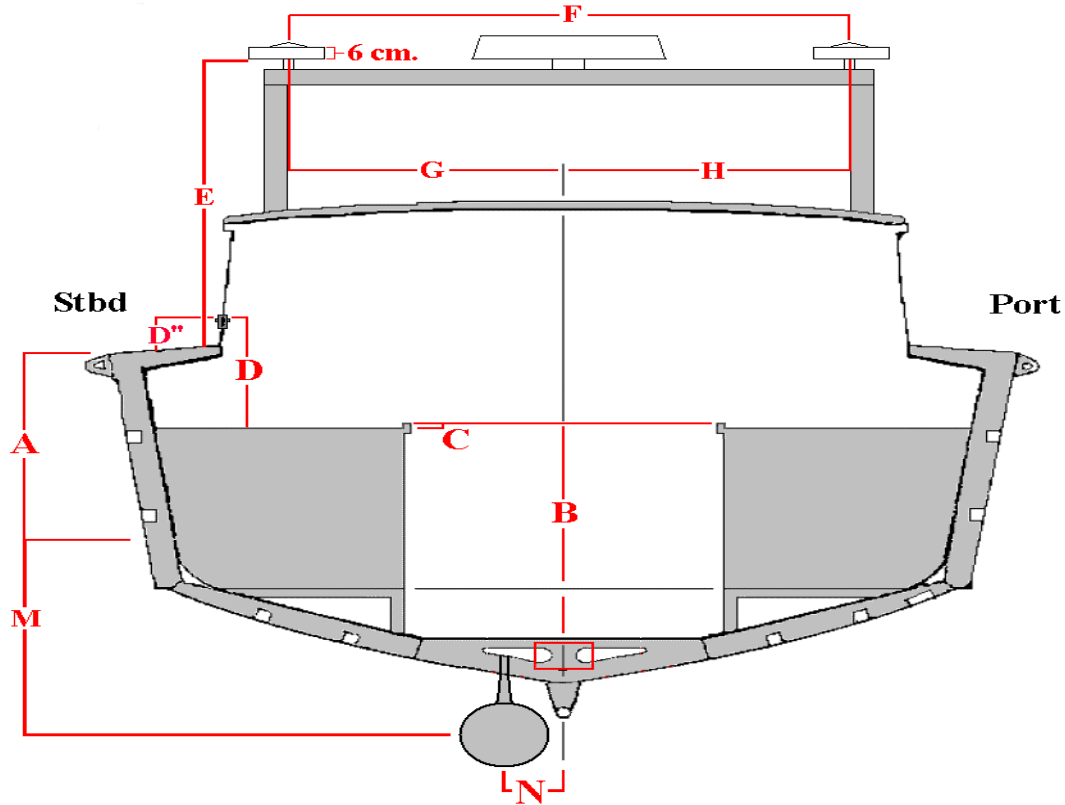

		X (athwartship)		Z (vertical)	
		cm.	date measured	cm.	date measured
Waterline to deck	A	n/a	n/a	98.3	Mar-04
MRU to counter top rail	B	n/a	n/a	97.2	Mar-04
Countertop rail to countertop	C	n/a	n/a	1.9	Mar-04
Countertop to thru-bulkhead fitting	D	n/a	n/a	70.9	Mar-04
Thru-bulkhead fitting to deck	D"	n/a	n/a	44.3	Mar-04
Deck to bottom of GPS	E	n/a	n/a	174.4	Mar-04
GPS to GPS	F	172.1	Mar-04	n/a	n/a
Centerline to Stbd GPS	G	86.1	Mar-04	n/a	n/a
Centerline to Port GPS	H	86.0	Mar-04	n/a	n/a
Waterline to SWMB transducer	M	67.2	Mar-04	n/a	n/a
Centerline to SWMB transducer	N	32.6	Mar-04	n/a	n/a

CARIS configuration is based on a Reference Position (RP)
 RP is assumed to be centerline, at the waterline, on the forward side
 of the bulkhead separating the engine compartment from the cabin

X athwartship distance [+ starboard]
Y along-ship distance [+ towards bow]
Z vertical distance [+ into water]

X	SWMB-ducer offset	0.33	Swath 1
	MRU to RP (mounted centerline)	0.00	
Y	RP to MB-ducer (equals C')	0.34	Navigation Gyro Heave Pitch Roll
	RP to MRU (equals B')	0.49	
Z	MB-ducer to RP (equals M)	0.67	
	MRU to RP (equals B+D-C-D"-A)	0.24	

Vessel Name: 1021_reson8101_HVF.hvf
Vessel created: July 09, 2004

Depth Sensor:

Sensor Class: Swath
Time Stamp: 2004-076 00:00

Transducer #1:

Pitch Offset: 0.710
Roll Offset: 0.150
Azimuth Offset: 0.080

DeltaX: 0.330
DeltaY: 0.340
DeltaZ: 0.670

Manufacturer: (null)
Model: sb8125
Serial Number: (null)

Navigation Sensor:

Time Stamp: 2004-076 00:00

Comments
Latency 0.060
DeltaX: 0.000
DeltaY: 0.490
DeltaZ: 0.240

Manufacturer: (null)
Model: (null)
Serial Number: (null)

Gyro Sensor:

Time Stamp: 2004-076 00:00

Comments
Latency 0.060

Entry 0) Draft: 0.000 Speed: 0.000

Heave Sensor:

Time Stamp: 2004-076 00:00

Comments (null)
Apply Yes
Latency 0.060
DeltaX: 0.000
DeltaY: 0.490
DeltaZ: 0.240

Manufacturer: (null)
 Model: (null)
 Serial Number: (null)

Pitch Sensor:

Time Stamp: 2004-076 00:00

Comments
 Apply Yes
 Latency 0.060
 Pitch offset: 0.000

Manufacturer: (null)
 Model: (null)
 Serial Number: (null)

Roll Sensor:

Time Stamp: 2004-076 00:00

Comments
 Apply Yes
 Latency 0.060
 Roll offset: 0.000

Manufacturer: (null)
 Model: (null)
 Serial Number: (null)

Draft Sensor:

Time Stamp: 2004-076 00:00

Apply Yes
 Comments

Entry 1) Draft: 0.000	Speed: 0.000
Entry 2) Draft: 0.000	Speed: 2.200
Entry 3) Draft: 0.010	Speed: 4.300
Entry 4) Draft: 0.020	Speed: 5.000
Entry 5) Draft: 0.030	Speed: 5.400
Entry 6) Draft: 0.050	Speed: 6.400
Entry 7) Draft: 0.060	Speed: 7.100
Entry 8) Draft: 0.070	Speed: 7.800
Entry 9) Draft: 0.060	Speed: 8.400
Entry 10) Draft: 0.040	Speed: 9.100

TPE

Time Stamp: 2004-001 00:00

Comments s.allen
 Offsets

Motion sensing unit to the transducer 1

X Head 1 0.326
 Y Head 1 0.146
 Z Head 1 0.398
 Motion sensing unit to the transducer 2
 X Head 2 0.000
 Y Head 2 0.000
 Z Head 2 0.000
 Navigation antenna to the transducer 1
 X Head 1 1.189
 Y Head 1 -0.506
 Z Head 1 3.399
 Navigation antenna to the transducer 2
 X Head 2 0.000
 Y Head 2 0.000
 Z Head 2 0.000

 Roll offset of transducer number 1 0.000
 Roll offset of transducer number 2 0.000

 Heave Error: 0.050 or 5.000" of heave amplitude.
 Measurement errors: 0.020
 Motion sensing unit alignment errors
 Gyro:0.000 Pitch:0.000 Roll:0.000
 Gyro measurement error: 0.020
 Roll measurement error: 0.020
 Pitch measurement error: 0.020
 Navigation measurement error: 0.700
 Transducer timing error: 0.010
 Navigation timing error: 0.001
 Gyro timing error: 0.001
 Heave timing error: 0.001
 PitchTimingStdDev: 0.001
 Roll timing error: 0.001
 Sound Velocity speed measurement error: 0.500
 Surface sound speed measurement error: 0.500
 Tide measurement error: 0.010
 Tide zoning error: 0.200
 Speed over ground measurement error: 0.030
 Dynamic loading measurement error: 0.030
 Static draft measurement error: 0.050
 Delta draft measurement error: 0.010

Svp Sensor:

Time Stamp: 2004-076 00:00

Comments

Svp #1:

Pitch Offset: 0.000
 Roll Offset: 0.000
 Azimuth Offset: 0.000

DeltaX: 0.000
 DeltaY: 0.000
 DeltaZ: 0.000

SVP #2:

Pitch Offset: 0.000
Roll Offset: 0.000
Azimuth Offset: 0.000

DeltaX: 0.330
DeltaY: 0.340
DeltaZ: 0.670

Hull 1016 (RA4) Vessel Offset Measurements, Elac 1180

9/12/2004

Description: Aluminum Jensen survey launch
 LOA: 29 feet
 Weigh: 14,000 lbs

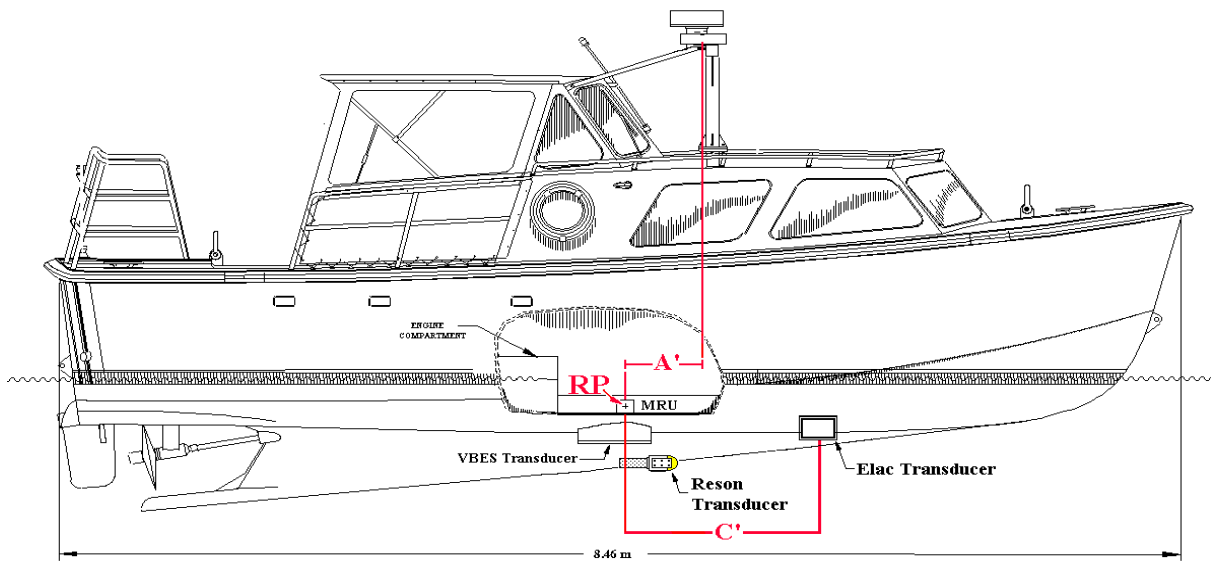

* Assume RP at waterline & centerline of engine bulkhead

		Y (along-ship)	
		cm.	date measured
RP to GPS	A'	35.0	May-00
RP to Elac ducer	C'	156.0	May-00

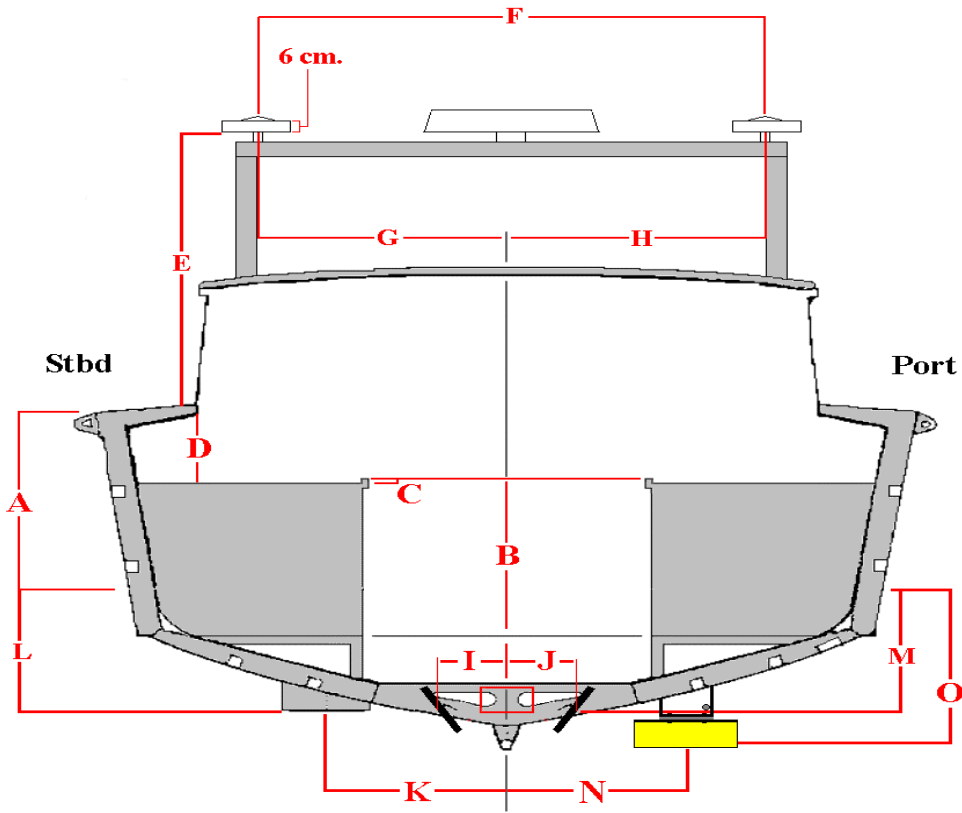

		X (athwartship)		Z (vertical)	
		cm.	date measured	cm.	date measured
Waterline to deck	A	n/a	n/a	96.5	May-00
MRU to counter top rail	B	n/a	n/a	104.9	May-00
Countertop rail	C	n/a	n/a	0.0	May-00
Countertop to deck	D	n/a	n/a	21.8	May-00
Deck to bottom of GPS	E	n/a	n/a	170.9	May-00
Waterline to VBES transducer	L	n/a	n/a	61.0	Mar-98
Waterline to Elac transducer	M	n/a	n/a	57.0	May-00
Waterline to Reson transducer	O	n/a	n/a	76.0	May-03
GPS to GPS	F	174.5	May-00	n/a	n/a
Centerline to Stbd GPS	G	87.5	May-00	n/a	n/a
Centerline to Port GPS	H	87.0	May-00	n/a	n/a
Centerline to Stbd Elac ducer	I	33.3	May-00	n/a	n/a
Centerline to Port Elac ducer	J	33.4	May-00	n/a	n/a
Centerline to VBES transducer	K	34.9	May-00	n/a	n/a
Centerline to Reson transducer	N	38.0	May-03	n/a	n/a

CARIS configuration is based on a Reference Position (RP)
 The RP has been defined to coincide with the location of the MRU

X athwartship distance [+ starboard]
Y along-ship distance [+ towards bow]
Z vertical distance [+ into water]

X	Elac transducer offset (equals average I & J) MRU to RP (mounted centerline)	+/- 0.33	Swath 1 Swath 2
		0.00	
Y	RP to Elac transducer (equals C') RP to MRU (equals B')	1.56	Navigation Gyro Heave Pitch Roll
		0.00	
Z	Elac transducer to RP (equals M-(B+D-C-A)) MRU to RP (equals B+D-C-A) MRU to waterline (equals A-D+C-B)	0.27	Waterline
		0.00	
		-0.30	

Vessel Name: 1016_Elac1180_HVF.hvf
Vessel created: July 09, 2004

Depth Sensor:

Sensor Class: Swath
Time Stamp: 2004-076 00:00

Transducer #1:

Pitch Offset: 0.400
Roll Offset: 0.000
Azimuth Offset: -1.500

DeltaX: 0.330
DeltaY: 1.560
DeltaZ: 0.270

Manufacturer: (null)
Model: en1180
Serial Number: (null)

Transducer #2:

Pitch Offset: -0.100
Roll Offset: 0.000
Azimuth Offset: -2.500

DeltaX: -0.330
DeltaY: 1.560
DeltaZ: 0.270

Manufacturer: (null)
Model: en1180
Serial Number: (null)

Navigation Sensor:

Time Stamp: 2004-076 00:00

Comments
Latency 0.060
DeltaX: 0.000
DeltaY: 0.000
DeltaZ: 0.000

Manufacturer: (null)
Model: (null)
Serial Number: (null)

Gyro Sensor:

Time Stamp: 2004-076 00:00

Comments

Latency 0.060

Entry 0) Draft: 0.000 Speed: 0.000

Heave Sensor:

Time Stamp: 2004-076 00:00

Comments
Apply Yes
Latency 0.060
DeltaX: 0.000
DeltaY: 0.000
DeltaZ: 0.000

Manufacturer: (null)
Model: (null)
Serial Number: (null)

Pitch Sensor:

Time Stamp: 2004-076 00:00

Comments
Apply Yes
Latency 0.060
Pitch offset: 0.000

Manufacturer: (null)
Model: (null)
Serial Number: (null)

Roll Sensor:

Time Stamp: 2004-076 00:00

Comments
Apply Yes
Latency 0.060
Roll offset: 0.000

Manufacturer: (null)
Model: (null)
Serial Number: (null)

Draft Sensor:

Time Stamp: 2004-076 00:00

Apply Yes
Comments
Entry 1) Draft: 0.000 Speed: 0.000
Entry 2) Draft: 0.010 Speed: 2.200
Entry 3) Draft: 0.020 Speed: 4.000
Entry 4) Draft: 0.030 Speed: 5.000
Entry 5) Draft: 0.040 Speed: 5.700

Entry 6) Draft: 0.070	Speed: 6.800
Entry 7) Draft: 0.090	Speed: 7.500
Entry 8) Draft: 0.100	Speed: 7.900
Entry 9) Draft: 0.090	Speed: 8.300
Entry 10) Draft: 0.040	Speed: 9.800

TPE

Time Stamp: 2004-001 00:00

Comments S.Allen
Offsets

Motion sensing unit to the transducer 1

X Head 1 0.333
Y Head 1 1.560
Z Head 1 0.268

Motion sensing unit to the transducer 2

X Head 2 0.334
Y Head 2 1.560
Z Head 2 0.268

Navigation antenna to the transducer 1

X Head 1 1.203
Y Head 1 1.210
Z Head 1 3.244

Navigation antenna to the transducer 2

X Head 2 0.536
Y Head 2 1.210
Z Head 2 3.244

Roll offset of transducer number 1 0.000

Roll offset of transducer number 2 0.000

Heave Error: 0.050 or 5.000" of heave amplitude.

Measurement errors: 0.020

Motion sensing unit alignment errors

Gyro:0.000 Pitch:0.000 Roll:0.000

Gyro measurement error: 0.000

Roll measurement error: 0.020

Pitch measurement error: 0.020

Navigation measurement error: 0.700

Transducer timing error: 0.010

Navigation timing error: 0.010

Gyro timing error: 0.010

Heave timing error: 0.010

PitchTimingStdDev: 0.010

Roll timing error: 0.010

Sound Velocity speed measurement error: 0.500

Surface sound speed measurement error: 0.500

Tide measurement error: 0.010

Tide zoning error: 0.200

Speed over ground measurement error: 0.030

Dynamic loading measurement error: 0.050

Static draft measurement error: 0.050

Delta draft measurement error: 0.010

Svp Sensor:

Time Stamp: 2004-076 00:00

Comments

Svp #1:

Pitch Offset: 0.000
Roll Offset: -37.800
Azimuth Offset: 0.000

DeltaX: -0.330
DeltaY: 1.560
DeltaZ: 0.270

SVP #2:

Pitch Offset: 0.000
Roll Offset: 37.800
Azimuth Offset: 0.000

DeltaX: 0.330
DeltaY: 1.560
DeltaZ: 0.270

WaterLine:

Time Stamp: 2004-076 00:00

Comments

Apply Yes

WaterLine -0.300

WaterLineStdDev 0.000

Hull 1016 (RA4) Vessel Offset Measurements, Reson 8125

12/22/2004

Description: Aluminum Jensen survey launch
 LOA: 29 feet
 Weigh: 14,000 lbs

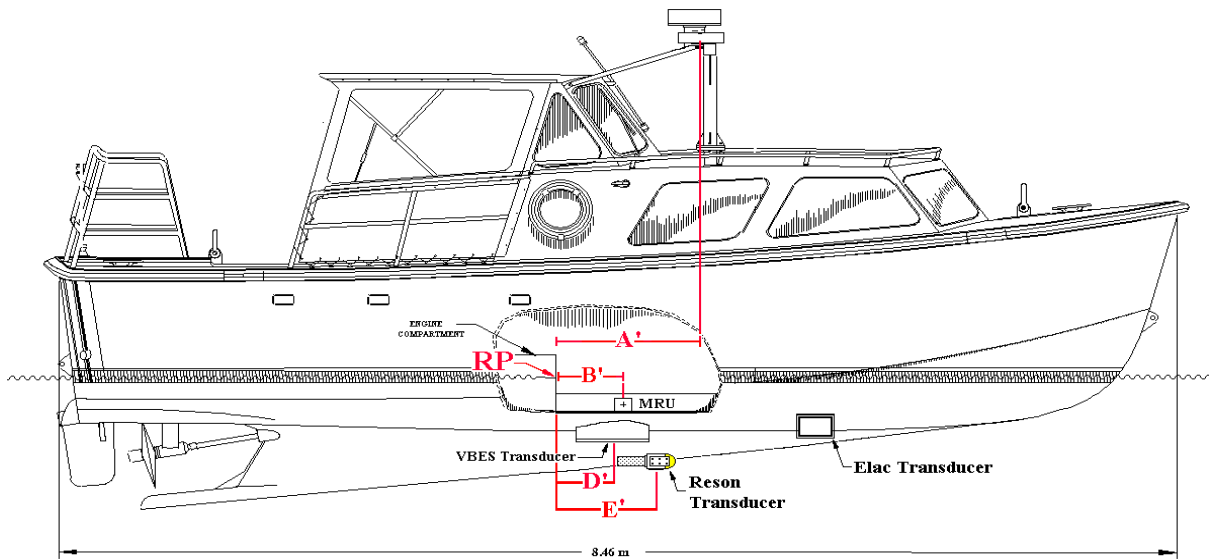

* Assume RP at waterline & centerline of engine bulkhead

		Y (along-ship)	
		cm.	date measured
RP to GPS	A'	83.0	May-00
RP to MRU	B'	48.0	May-00
RP to VBES ducer	D'	43.4	May-00
RP to Reson ducer	E'	81.0	May-03

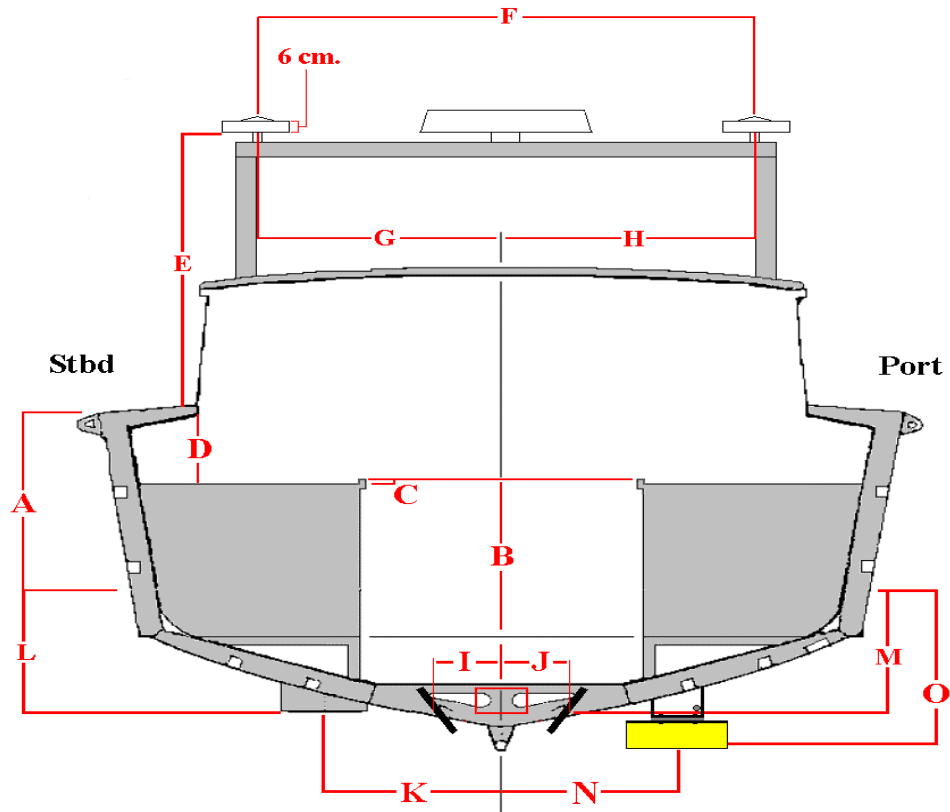

		X (athwartship)		Z (vertical)	
		cm.	date measured	cm.	date measured
Waterline to deck	A	n/a	n/a	96.5	May-00
MRU to counter top rail	B	n/a	n/a	104.9	May-00
Countertop rail	C	n/a	n/a	0.0	May-00
Countertop to deck	D	n/a	n/a	21.8	May-00
Deck to bottom of GPS	E	n/a	n/a	170.9	May-00
Waterline to VBES transducer	L	n/a	n/a	61.0	Mar-98
Waterline to Elac transducer	M	n/a	n/a	57.0	May-00
Waterline to Reson transducer	O	n/a	n/a	76.0	May-03
GPS to GPS	F	174.5	May-00	n/a	n/a
Centerline to Stbd GPS	G	87.5	May-00	n/a	n/a
Centerline to Port GPS	H	87.0	May-00	n/a	n/a
Centerline to Stbd Elac ducer	I	33.3	May-00	n/a	n/a
Centerline to Port Elac ducer	J	33.4	May-00	n/a	n/a
Centerline to VBES transducer	K	34.9	May-00	n/a	n/a
Centerline to Reson transducer	N	38.0	May-03	n/a	n/a

CARIS configuration is based on a Reference Position (RP)
 RP is assumed to be centerline, at the waterline, on the forward side
 of the bulkhead separating the engine compartment from the cabin

- X** athwartship distance [+ starboard]
- Y** along-ship distance [+ towards bow]
- Z** vertical distance [+ into water]

X	Reson transducer offset (equals N)	-0.38	Swath 1
	MRU to RP (mounted centerline)	0.00	
Y	RP to Reson transducer (equals E')	0.81	Navigation Gyro Heave Pitch Roll
	RP to MRU (equals B')	0.48	
Z	Reson transducer to RP (equals O)	0.76	
	MRU to RP (equals B+D-C-A)	0.30	

Vessel Name: 1016_Reson8125_hvf.hvf
Vessel created: July 07, 2004

Depth Sensor:

Sensor Class: Swath
Time Stamp: 2004-075 00:00

Transducer #1:

Pitch Offset: -0.430
Roll Offset: 0.110
Azimuth Offset: -1.500

DeltaX: -0.380
DeltaY: 0.810
DeltaZ: 0.760

Manufacturer: Reson
Model: sb8125
Serial Number: 29979

Navigation Sensor:

Time Stamp: 2004-075 00:00

Comments (null)
Latency 0.050
DeltaX: 0.000
DeltaY: 0.480
DeltaZ: 0.300

Manufacturer: TSS POS/MV
Model: (null)
Serial Number: 295

Gyro Sensor:

Time Stamp: 2004-075 00:00

Comments
Latency 0.050

Entry 0) Draft: 0.000 Speed: 0.000

Heave Sensor:

Time Stamp: 2004-075 00:00

Comments
Apply Yes
Latency 0.050
DeltaX: 0.000
DeltaY: 0.480

DeltaZ: 0.300

Manufacturer: (null)
 Model: (null)
 Serial Number: (null)

Pitch Sensor:

Time Stamp: 2004-075 00:00

Comments
 Apply Yes
 Latency 0.050
 Pitch offset: 0.000

Manufacturer: (null)
 Model: (null)
 Serial Number: (null)

Roll Sensor:

Time Stamp: 2004-075 00:00

Comments
 Apply Yes
 Latency 0.050
 Roll offset: 0.000

Manufacturer: (null)
 Model: (null)
 Serial Number: (null)

Draft Sensor:

Time Stamp: 2004-075 00:00

Apply Yes
 Comments
 Entry 1) Draft: 0.000 Speed: 0.000
 Entry 2) Draft: 0.010 Speed: 2.200
 Entry 3) Draft: 0.020 Speed: 4.000
 Entry 4) Draft: 0.030 Speed: 5.000
 Entry 5) Draft: 0.040 Speed: 5.700
 Entry 6) Draft: 0.070 Speed: 6.800
 Entry 7) Draft: 0.090 Speed: 7.500
 Entry 8) Draft: 0.100 Speed: 7.900
 Entry 9) Draft: 0.090 Speed: 8.300
 Entry 10) Draft: 0.040 Speed: 9.800

TPE

Time Stamp: 2004-075 00:00

Comments S.allen
 Offsets

Motion sensing unit to the transducer 1

X Head 1 -0.380

Y Head 1 0.330

Z Head 1 0.458

Motion sensing unit to the transducer 2

X Head 2 0.000

Y Head 2 0.000

Z Head 2 0.000

Navigation antenna to the transducer 1

X Head 1 0.490

Y Head 1 0.020

Z Head 1 3.434

Navigation antenna to the transducer 2

X Head 2 0.000

Y Head 2 0.000

Z Head 2 0.000

Roll offset of transducer number 1 0.000

Roll offset of transducer number 2 0.000

Heave Error: 0.050 or 5.000" of heave amplitude.

Measurement errors: 0.020

Motion sensing unit alignment errors

Gyro:0.000 Pitch:0.000 Roll:0.000

Gyro measurement error: 0.020

Roll measurement error: 0.020

Pitch measurement error: 0.020

Navigation measurement error: 0.700

Transducer timing error: 0.010

Navigation timing error: 0.010

Gyro timing error: 0.010

Heave timing error: 0.010

PitchTimingStdDev: 0.010

Roll timing error: 0.010

Sound Velocity speed measurement error: 0.500

Surface sound speed measurement error: 0.500

Tide measurement error: 0.010

Tide zoning error: 0.200

Speed over ground measurement error: 0.030

Dynamic loading measurement error: 0.030

Static draft measurement error: 0.050

Delta draft measurement error: 0.010

Time Stamp: 2004-180 00:00

Comments A.McKinney

Offsets

Motion sensing unit to the transducer 1

X Head 1 -0.380

Y Head 1 0.330

Z Head 1 0.458

Motion sensing unit to the transducer 2

X Head 2 0.000

Y Head 2 0.000

Z Head 2 0.000

Navigation antenna to the transducer 1

X Head 1 0.490

Y Head 1 0.020

Z Head 1 3.434
 Navigation antenna to the transducer 2
 X Head 2 0.000
 Y Head 2 0.000
 Z Head 2 0.000

Roll offset of transducer number 1 0.000
 Roll offset of transducer number 2 0.000

Heave Error: 0.050 or 5.000" of heave amplitude.
 Measurement errors: 0.020
 Motion sensing unit alignment errors
 Gyro:0.000 Pitch:0.000 Roll:0.000
 Gyro measurement error: 0.020
 Roll measurement error: 0.020
 Pitch measurement error: 0.020
 Navigation measurement error: 0.700
 Transducer timing error: 0.010
 Navigation timing error: 0.001
 Gyro timing error: 0.001
 Heave timing error: 0.001
 PitchTimingStdDev: 0.001
 Roll timing error: 0.001
 Sound Velocity speed measurement error: 0.500
 Surface sound speed measurement error: 0.500
 Tide measurement error: 0.010
 Tide zoning error: 0.200
 Speed over ground measurement error: 0.030
 Dynamic loading measurement error: 0.030
 Static draft measurement error: 0.050
 Delta draft measurement error: 0.010

Svp Sensor:

Time Stamp: 2004-075 00:00

Comments

Svp #1:

Pitch Offset: 0.000
 Roll Offset: 0.000
 Azimuth Offset: 0.000

DeltaX: 0.000
 DeltaY: 0.000
 DeltaZ: 0.000

SVP #2:

Pitch Offset: 0.000
 Roll Offset: 0.000
 Azimuth Offset: 0.000

DeltaX: -0.380
 DeltaY: 0.810
 DeltaZ: 0.760

Hull 1006 (RA5) Vessel Offset Measurements, Reson 8101

7/10/2004

Description: Aluminum Jensen survey launch

LOA: 29 feet

Weigh: 14,000 lbs

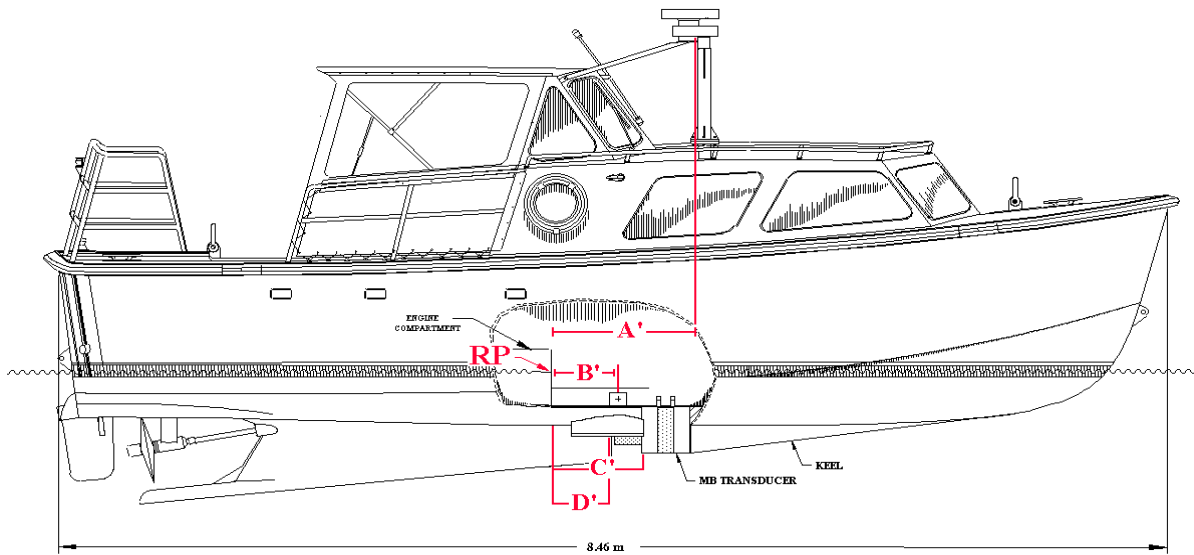

* Assume RP at waterline & centerline of engine bulkhead

		Y (along-ship)	
		cm.	date measured
RP to GPS	A'	92.0	Mar-04
RP to MRU	B'	48.0	Mar-04
RP to SWMB ducer	C'	73.3	Mar-99
RP to VBES ducer	D'	40.5	May-00

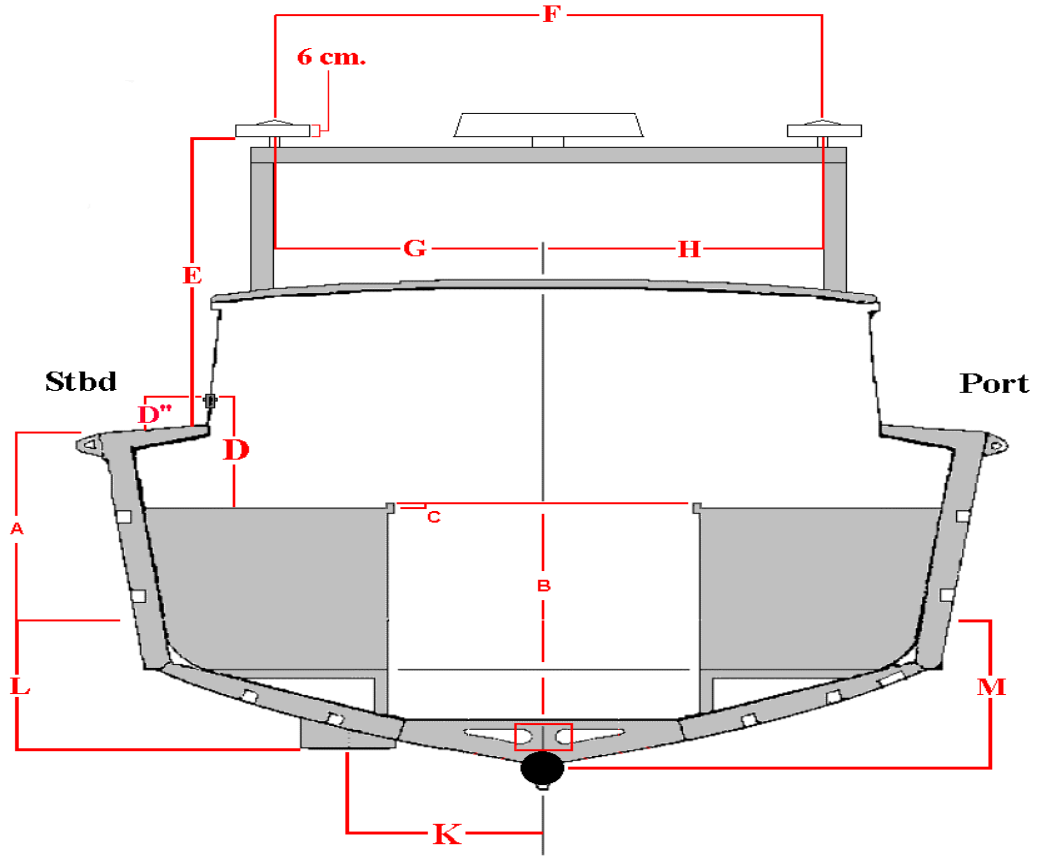

		X (athwartship)		Z (vertical)	
		cm.	date measured	cm.	date measured
Waterline to deck	A	n/a	n/a	100.0	Mar-99
MRU to counter top rail	B	n/a	n/a	105.2	Mar-04
Countertop rail to countertop	C	n/a	n/a	1.9	Mar-04
Countertop to thru-bulkhead fitting	D	n/a	n/a	46.5	Mar-04
Thru-bulkhead fitting to deck	D"	n/a	n/a	29.0	Mar-04
Deck to bottom of GPS	E	n/a	n/a	177.0	Mar-04
Waterline to SWMB transducer	M	n/a	n/a	49.6	Mar-99
Waterline to VBES transducer	L	n/a	n/a	53.0	Apr-98
GPS to GPS	F	181.7	Mar-04	n/a	n/a
Centerline to Stbd GPS	G	90.0	Apr-98	n/a	n/a
Centerline to Port GPS	H	91.0	Apr-98	n/a	n/a
Centerline to VBES transducer	K	50.5	Mar-04	n/a	n/a

CARIS configuration is based on a Reference Position (RP)
 RP is assumed to be centerline, at the waterline, on the forward side
 of the bulkhead separating the engine compartment from the cabin

- X** athwartship distance [+ starboard]
- Y** along-ship distance [+ towards bow]
- Z** vertical distance [+ into water]

X	SWMB-ducer offset (mounted centerline)	0.00	Swath 1
	MRU to RP (mounted centerline)	0.00	
Y	RP to MB-ducer (equals C')	0.73	Navigation Gyro Heave Pitch Roll
	RP to MRU (equals B')	0.48	
Z	MB-ducer to RP (equals M)	0.50	
	MRU to RP (equals B+D-C-D"-A)	0.21	

Vessel Name: 1006_Reson8101_HVF.hvf
Vessel created: July 09, 2004

Depth Sensor:

Sensor Class: Swath
Time Stamp: 2004-076 00:00

Transducer #1:

Pitch Offset: 2.010
Roll Offset: -0.850
Azimuth Offset: 0.590

DeltaX: 0.000
DeltaY: 0.730
DeltaZ: 0.500

Manufacturer: Reson
Model: sb8101
Serial Number: 31676

Navigation Sensor:

Time Stamp: 2004-076 00:00

Comments (null)

Latency 0.000
DeltaX: 0.000
DeltaY: 0.480
DeltaZ: 0.210

Manufacturer: POS/MV
Model: 320
Serial Number: 304

Time Stamp: 2004-192 00:00

Comments precise timing upgrade

Latency 0.060
DeltaX: 0.000
DeltaY: 0.480
DeltaZ: 0.210

Manufacturer: POS/MV
Model: 320
Serial Number: 304

Gyro Sensor:

Time Stamp: 2004-076 00:00

Comments
Latency 0.000

Entry 0) Draft: 0.000 Speed: 0.000

Time Stamp: 2004-192 00:00

Comments
Latency 0.060

Heave Sensor:

Time Stamp: 2004-076 00:00

Comments
Apply Yes
Latency 0.000
DeltaX: 0.000
DeltaY: 0.480
DeltaZ: 0.210

Manufacturer: POS/MV
Model: 320
Serial Number: 304

Time Stamp: 2004-192 00:00

Comments
Apply Yes
Latency 0.060
DeltaX: 0.000
DeltaY: 0.480
DeltaZ: 0.210

Manufacturer:
Model:
Serial Number:

Pitch Sensor:

Time Stamp: 2004-076 00:00

Comments
Apply Yes
Latency 0.000
Pitch offset: 0.000

Manufacturer: POS/MV
Model: 320
Serial Number: 304

Time Stamp: 2004-192 00:00

Comments
Apply Yes
Latency 0.060
Pitch offset: 0.000

Manufacturer:
 Model:
 Serial Number:

Roll Sensor:

Time Stamp: 2004-076 00:00

Comments
 Apply Yes
 Latency 0.000
 Roll offset: 0.000

Manufacturer: POS/MV
 Model: 320
 Serial Number: 304

Time Stamp: 2004-192 00:00

Comments
 Apply Yes
 Latency 0.060
 Roll offset: 0.000

Manufacturer:
 Model:
 Serial Number:

Draft Sensor:

Time Stamp: 2004-076 00:00

Apply Yes
 Comments
 Entry 1) Draft: 0.000 Speed: 0.000
 Entry 2) Draft: 0.000 Speed: 2.000
 Entry 3) Draft: 0.030 Speed: 4.000
 Entry 4) Draft: 0.070 Speed: 5.200
 Entry 5) Draft: 0.080 Speed: 5.700
 Entry 6) Draft: 0.090 Speed: 6.400
 Entry 7) Draft: 0.110 Speed: 6.900
 Entry 8) Draft: 0.120 Speed: 7.400
 Entry 9) Draft: 0.110 Speed: 7.900
 Entry 10) Draft: 0.100 Speed: 8.700

TPE

Time Stamp: 2004-001 00:00

Comments S.Allen
 Offsets

Motion sensing unit to the transducer 1
 X Head 1 0.000
 Y Head 1 0.253

Z Head 1 0.250
 Motion sensing unit to the transducer 2
 X Head 2 0.000
 Y Head 2 0.000
 Z Head 2 0.000
 Navigation antenna to the transducer 1
 X Head 1 0.910
 Y Head 1 -0.187
 Z Head 1 3.266
 Navigation antenna to the transducer 2
 X Head 2 0.000
 Y Head 2 0.000
 Z Head 2 0.000

Roll offset of transducer number 1 0.000
 Roll offset of transducer number 2 0.000

Heave Error: 0.050 or 5.000" of heave amplitude.
 Measurement errors: 0.020
 Motion sensing unit alignment errors
 Gyro:0.000 Pitch:0.000 Roll:0.000
 Gyro measurement error: 0.020
 Roll measurement error: 0.020
 Pitch measurement error: 0.020
 Navigation measurement error: 0.700
 Transducer timing error: 0.010
 Navigation timing error: 0.010
 Gyro timing error: 0.010
 Heave timing error: 0.010
 PitchTimingStdDev: 0.010
 Roll timing error: 0.010
 Sound Velocity speed measurement error: 0.500
 Surface sound speed measurement error: 0.500
 Tide measurement error: 0.010
 Tide zoning error: 0.200
 Speed over ground measurement error: 0.030
 Dynamic loading measurement error: 0.030
 Static draft measurement error: 0.050
 Delta draft measurement error: 0.010

Time Stamp: 2004-180 00:00

Comments A.McKinney
 Offsets

Motion sensing unit to the transducer 1
 X Head 1 0.000
 Y Head 1 0.253
 Z Head 1 0.250
 Motion sensing unit to the transducer 2
 X Head 2 0.000
 Y Head 2 0.000
 Z Head 2 0.000
 Navigation antenna to the transducer 1
 X Head 1 0.910
 Y Head 1 -0.187
 Z Head 1 3.266
 Navigation antenna to the transducer 2
 X Head 2 0.000

Y Head 2 0.000

Z Head 2 0.000

Roll offset of transducer number 1 0.000

Roll offset of transducer number 2 0.000

Heave Error: 0.050 or 5.000" of heave amplitude.

Measurement errors: 0.020

Motion sensing unit alignment errors

Gyro:0.000 Pitch:0.000 Roll:0.000

Gyro measurement error: 0.020

Roll measurement error: 0.020

Pitch measurement error: 0.020

Navigation measurement error: 0.700

Transducer timing error: 0.010

Navigation timing error: 0.001

Gyro timing error: 0.001

Heave timing error: 0.001

PitchTimingStdDev: 0.001

Roll timing error: 0.001

Sound Velocity speed measurement error: 0.500

Surface sound speed measurement error: 0.500

Tide measurement error: 0.010

Tide zoning error: 0.200

Speed over ground measurement error: 0.030

Dynamic loading measurement error: 0.030

Static draft measurement error: 0.050

Delta draft measurement error: 0.010

Svp Sensor:

Time Stamp: 2004-076 00:00

Comments

Svp #1:

Pitch Offset: 0.000

Roll Offset: 0.000

Azimuth Offset: 0.000

DeltaX: 0.000

DeltaY: 0.000

DeltaZ: 0.000

SVP #2:

Pitch Offset: 0.000

Roll Offset: 0.000

Azimuth Offset: 0.000

DeltaX: 0.000

DeltaY: 0.730

DeltaZ: 0.500

Vessel Name: 1006_NonEchosounder_DP
Vessel created: August 24, 2004

Depth Sensor:

Sensor Class: Swath
 Time Stamp: 2004-001 00:00

Transducer #1:

Pitch Offset: 0.000
 Roll Offset: 0.000
 Azimuth Offset: 0.000

DeltaX: 0.000
 DeltaY: 0.000
 DeltaZ: 0.000

Manufacturer:
 Model: Unknown
 Serial Number:

Transducer #2:

Pitch Offset: 0.000
 Roll Offset: 0.000
 Azimuth Offset: 0.000

DeltaX: 0.000
 DeltaY: 0.000
 DeltaZ: 0.000

Manufacturer:
 Model: Unknown
 Serial Number:

Navigation Sensor:

Time Stamp: 2004-001 00:00

Comments
 Latency 0.000
 DeltaX: 0.000
 DeltaY: 0.000
 DeltaZ: 0.000

Manufacturer: (null)
 Model: (null)
 Serial Number: (null)

Gyro Sensor:

Time Stamp: 2004-001 00:00

Comments

Latency 0.000

Entry 0) Draft: 0.000 Speed: 0.000

Hull 1015 (RA6) Vessel Offset Measurements, Elac 1180

9/12/2004

Description: Aluminum Jensen survey launch

LOA: 29 feet

Weigh: 14,000 lbs

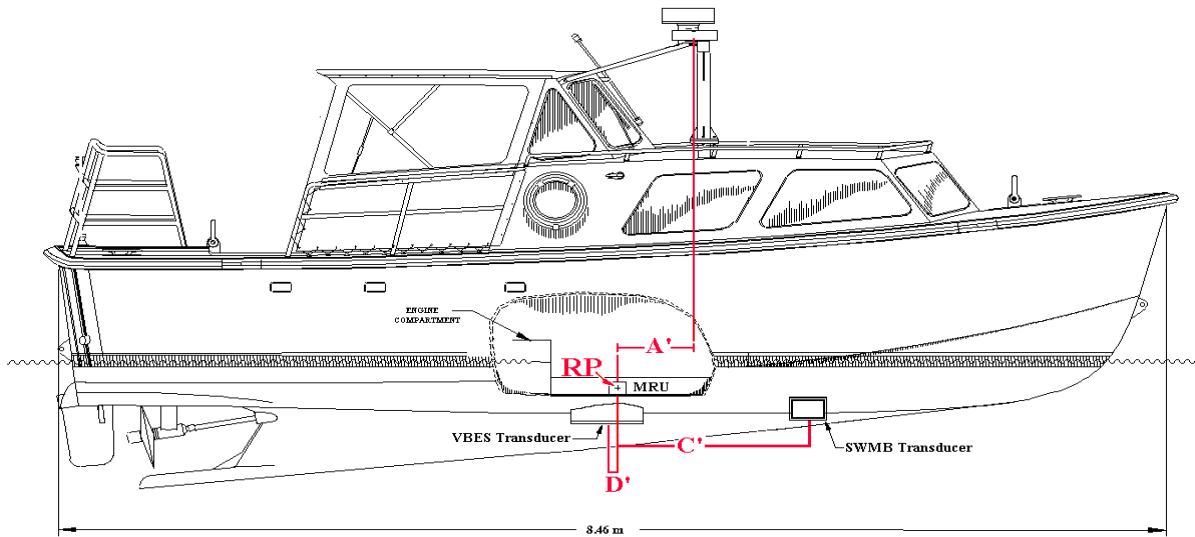

* Assume RP at waterline & centerline of engine bulkhead

		Y (along-ship)	
		cm.	date measured
RP to GPS	A'	51.2	May-00
RP to SWMB ducer	C'	156.0	May-00
RP to VBES ducer	D'	3.2	May-00

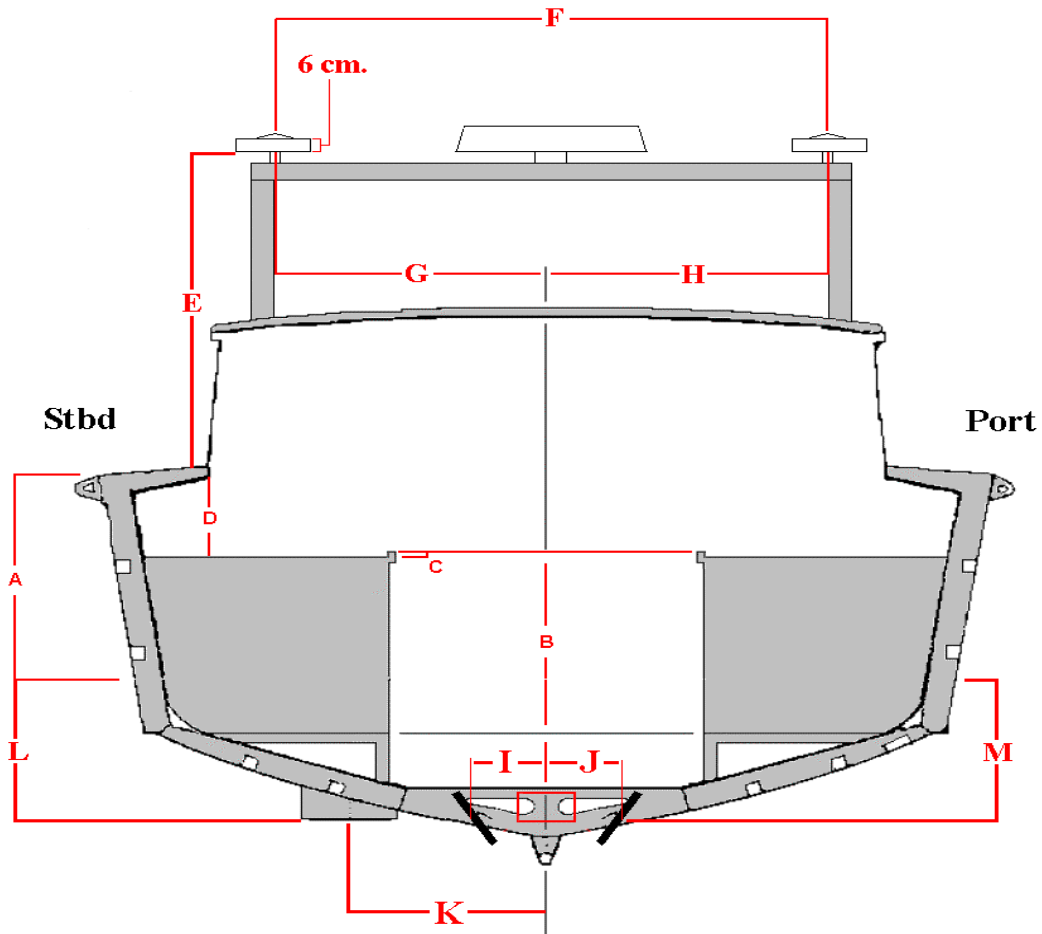

		X (athwartship)		Z (vertical)	
		cm.	date measured	cm.	date measured
Waterline to deck	A	n/a	n/a	100.5	May-00
MRU to counter top rail	B	n/a	n/a	103.6	May-00
Countertop rail	C	n/a	n/a	0.0	May-00
Countertop to deck	D	n/a	n/a	21.4	May-00
Deck to bottom of GPS	E	n/a	n/a	175.6	May-00
Waterline to VBES transducer	L	n/a	n/a	42.0	May-00
Waterline to SWMB transducer	M	n/a	n/a	46.2	May-00
GPS to GPS	F	170.3	May-00	n/a	n/a
Centerline to Stbd GPS	G	85.8	May-00	n/a	n/a
Centerline to Port GPS	H	84.5	May-00	n/a	n/a
Centerline to Stbd SWMB ducer	I	33.8	May-00	n/a	n/a
Centerline to Port SWMB ducer	J	34.4	May-00	n/a	n/a
Centerline to VBES transducer	K	51.8	May-00	n/a	n/a

CARIS configuration is based on a Reference Position (RP)
 The RP has been defined to coincide with the location of the MRU

X athwartship distance [+ starboard]
Y along-ship distance [+ towards bow]
Z vertical distance [+ into water]

X	SWMB-ducer offset (equals average I & J)	+/-	0.34	Swath 1
	MRU to RP (mounted centerline)		0.00	Swath 2
Y	RP to MB-ducer (equals C')		1.56	Navigation
	RP to MRU (equals B')		0.00	Gyro
Z	MB-ducer to RP (equals M-(B+D-C-A))		0.22	Heave
	MRU to RP		0.00	Pitch
	MRU to waterline (equals A-D+C-B)		-0.25	Roll
				Waterline

Vessel Name: 1015_Elac1180_HVF.hvf
Vessel created: July 09, 2004

Depth Sensor:

Sensor Class: Swath
Time Stamp: 2003-086 00:00

Transducer #1:

Pitch Offset: -1.200
Roll Offset: 0.000
Azimuth Offset: -0.300

DeltaX: 0.340
DeltaY: 1.560
DeltaZ: 0.220

Manufacturer: (null)
Model: en1180
Serial Number: (null)

Transducer #2:

Pitch Offset: -0.650
Roll Offset: 0.000
Azimuth Offset: 0.100

DeltaX: -0.340
DeltaY: 1.560
DeltaZ: 0.220

Manufacturer: (null)
Model: en1180
Serial Number: (null)

Navigation Sensor:

Time Stamp: 2003-086 00:00

Comments
Latency 0.030
DeltaX: 0.000
DeltaY: 0.000
DeltaZ: 0.000

Manufacturer: (null)
Model: (null)
Serial Number: (null)

Gyro Sensor:

Time Stamp: 2004-086 00:00

Comments
Latency 0.030

Entry 0) Draft: 0.000 Speed: 0.000

Heave Sensor:

Time Stamp: 2004-086 00:00

Comments
Apply Yes
Latency 0.030
DeltaX: 0.000
DeltaY: 0.000
DeltaZ: 0.000

Manufacturer: (null)
Model: (null)
Serial Number: (null)

Pitch Sensor:

Time Stamp: 2004-086 00:00

Comments
Apply Yes
Latency 0.030
Pitch offset: 0.000

Manufacturer: (null)
Model: (null)
Serial Number: (null)

Roll Sensor:

Time Stamp: 2004-086 00:00

Comments
Apply Yes
Latency 0.030
Roll offset: 0.000

Manufacturer: (null)
Model: (null)
Serial Number: (null)

Draft Sensor:

Time Stamp: 2004-086 00:00

Apply Yes
Comments
Entry 1) Draft: 0.000 Speed: 0.000

Entry 2) Draft: 0.000	Speed: 1.600
Entry 3) Draft: 0.010	Speed: 3.200
Entry 4) Draft: 0.020	Speed: 4.300
Entry 5) Draft: 0.010	Speed: 5.100
Entry 6) Draft: 0.010	Speed: 6.100
Entry 7) Draft: 0.020	Speed: 6.500
Entry 8) Draft: 0.030	Speed: 6.900
Entry 9) Draft: 0.010	Speed: 7.700
Entry 10) Draft: -0.040	Speed: 8.500

TPE

Time Stamp: 2004-001 00:00

Comments S.Allen

Offsets

Motion sensing unit to the transducer 1

X Head 1 0.338

Y Head 1 1.560

Z Head 1 0.217

Motion sensing unit to the transducer 2

X Head 2 -0.344

Y Head 2 1.560

Z Head 2 0.217

Navigation antenna to the transducer 1

X Head 1 1.183

Y Head 1 1.048

Z Head 1 3.223

Navigation antenna to the transducer 2

X Head 2 0.501

Y Head 2 1.048

Z Head 2 3.223

Roll offset of transducer number 1 0.000

Roll offset of transducer number 2 0.000

Heave Error: 0.050 or 5.000" of heave amplitude.

Measurement errors: 0.020

Motion sensing unit alignment errors

Gyro:0.000 Pitch:0.000 Roll:0.000

Gyro measurement error: 0.020

Roll measurement error: 0.020

Pitch measurement error: 0.020

Navigation measurement error: 0.700

Transducer timing error: 0.010

Navigation timing error: 0.010

Gyro timing error: 0.010

Heave timing error: 0.010

PitchTimingStdDev: 0.010

Roll timing error: 0.010

Sound Velocity speed measurement error: 0.500

Surface sound speed measurement error: 0.500

Tide measurement error: 0.010

Tide zoning error: 0.200

Speed over ground measurement error: 0.030

Dynamic loading measurement error: 0.030

Static draft measurement error: 0.050

Delta draft measurement error: 0.010

Time Stamp: 2004-214 00:00

Comments S.Allen-corrects mistake with mru to trans offset
Offsets

Motion sensing unit to the transducer 1

X Head 1 0.338

Y Head 1 1.560

Z Head 1 0.217

Motion sensing unit to the transducer 2

X Head 2 0.334

Y Head 2 1.560

Z Head 2 0.217

Navigation antenna to the transducer 1

X Head 1 1.183

Y Head 1 1.048

Z Head 1 3.223

Navigation antenna to the transducer 2

X Head 2 0.501

Y Head 2 1.048

Z Head 2 3.223

Roll offset of transducer number 1 0.000

Roll offset of transducer number 2 0.000

Heave Error: 0.050 or 5.000" of heave amplitude.

Measurement errors: 0.020

Motion sensing unit alignment errors

Gyro:0.000 Pitch:0.000 Roll:0.000

Gyro measurement error: 0.020

Roll measurement error: 0.020

Pitch measurement error: 0.020

Navigation measurement error: 0.700

Transducer timing error: 0.010

Navigation timing error: 0.010

Gyro timing error: 0.010

Heave timing error: 0.010

PitchTimingStdDev: 0.010

Roll timing error: 0.010

Sound Velocity speed measurement error: 0.500

Surface sound speed measurement error: 0.500

Tide measurement error: 0.010

Tide zoning error: 0.200

Speed over ground measurement error: 0.030

Dynamic loading measurement error: 0.030

Static draft measurement error: 0.050

Delta draft measurement error: 0.010

Svp Sensor:

Time Stamp: 2004-086 00:00

Comments

Svp #1:

Pitch Offset: 0.000

Roll Offset: 0.000

Azimuth Offset: 0.000

DeltaX: -0.340
DeltaY: 1.560
DeltaZ: 0.220

SVP #2:

Pitch Offset: 0.000
Roll Offset: 0.000
Azimuth Offset: 0.000

DeltaX: 0.340
DeltaY: 1.560
DeltaZ: 0.220

WaterLine:

Time Stamp: 2004-086 00:00

Comments

Apply Yes

WaterLine -0.250

WaterLineStdDev 0.000

Hull 817 (RA7) Vessel Offset Measurements, Ross 950

10/15/2004

Description: Aluminum SeaArk survey skiff

LOA: 16.5 feet

Weigh: lbs

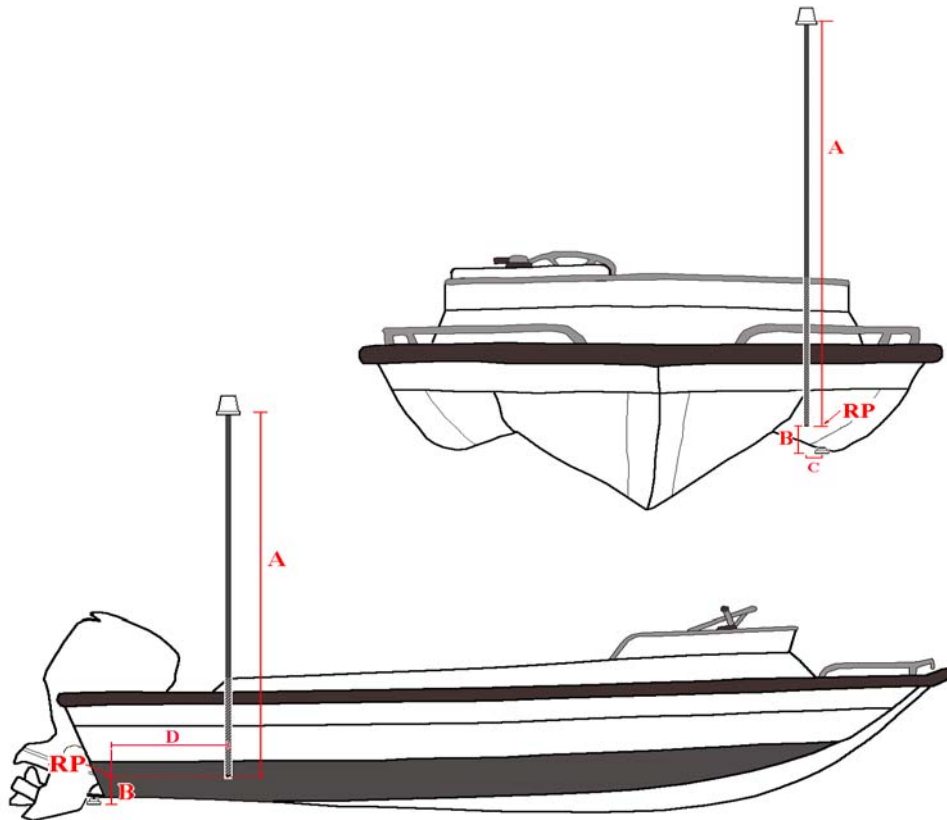

		X (athwartship)		Y (along-ship)		Z (vertical)	
		cm.	date measured	cm.	date measured	cm.	date measured
RP to GPS (vertical)	A	n/a	n/a	n/a	n/a	230.0	May-04
RP to transducer	B	n/a	n/a	n/a	n/a	29.5	May-04
RP to GPS (athwartship)	C	14.0	May-04	n/a	n/a	n/a	n/a
RP to GPS (along-ship)	D	n/a	n/a	83.0	May-04	n/a	n/a

CARIS configuration is based on a Reference Position (RP)
 On hull 817 (RA7) the RP is assumed to be at the waterline
 directly above the transducer

- X** athwartship distance [+ starboard]
- Y** along-ship distance [+ towards bow]
- Z** vertical distance [+ into water]

X	RP to VBES transducer	0.000	Singlebeam
	RP to GPS (equals C)	0.140	
Y	RP to VBES transducer	0.000	Navigation
	RP to GPS (equals D)	0.830	
Z	RP to VBES transducer (equals B)	0.295	
	RP to GPS (equals A)	-2.300	

Vessel Name: 817_Echosounder_DP
Vessel created: August 24, 2004

Depth Sensor:

Sensor Class: Swath
 Time Stamp: 2003-112 00:00

Transducer #1:

 Pitch Offset: 0.000
 Roll Offset: 0.000
 Azimuth Offset: 0.000

DeltaX: 0.000
 DeltaY: 0.000
 DeltaZ: 0.295

Manufacturer: Ross Laboratoriies
 Model: 950
 Serial Number:

Navigation Sensor:

Time Stamp: 2003-112 00:00

Comments
 Latency 0.000
 DeltaX: 0.140
 DeltaY: 0.830
 DeltaZ: -2.300

Manufacturer: (null)
 Model: (null)
 Serial Number: (null)

Draft Sensor:

Time Stamp: 2003-112 00:00

Apply Yes
 Comments

Entry 1) Draft: 0.000	Speed: 0.000
Entry 2) Draft: 0.000	Speed: 1.000
Entry 3) Draft: 0.000	Speed: 2.400
Entry 4) Draft: 0.000	Speed: 4.500
Entry 5) Draft: 0.000	Speed: 6.000
Entry 6) Draft: 0.000	Speed: 7.500
Entry 7) Draft: 0.000	Speed: 10.000
Entry 8) Draft: 0.000	Speed: 11.500
Entry 9) Draft: 0.000	Speed: 13.000
Entry 10) Draft: 0.000	Speed: 15.000

Svp Sensor:

Time Stamp: 2003-112 00:00

Comments

Svp #1:

Pitch Offset: 0.000

Roll Offset: 0.000

Azimuth Offset: 0.000

DeltaX: 0.000

DeltaY: 0.000

DeltaZ: 0.000

SVP #2:

Pitch Offset: 0.000

Roll Offset: 0.000

Azimuth Offset: 0.000

DeltaX: 0.000

DeltaY: 0.000

DeltaZ: 0.295

WaterLine:

Time Stamp: 2003-112 00:00

Comments

Apply Yes

WaterLine 0.000

WaterLineStdDev 0.000

Vessel Name: 817_NonEchosounder_DP
Vessel created: August 24, 2004

Depth Sensor:

Sensor Class: Swath
 Time Stamp: 2003-112 00:00

Transducer #1:

 Pitch Offset: 0.000
 Roll Offset: 0.000
 Azimuth Offset: 0.000

DeltaX: 0.000
 DeltaY: 0.000
 DeltaZ: 0.000

Manufacturer: Ross Laboratories
 Model: 950
 Serial Number:

Navigation Sensor:

Time Stamp: 2003-112 00:00

Comments
 Latency 0.000
 DeltaX: 0.000
 DeltaY: 0.000
 DeltaZ: 0.000

Manufacturer: (null)
 Model: (null)
 Serial Number: (null)

Draft Sensor:

Time Stamp: 2003-112 00:00

Apply Yes
 Comments

Entry 1) Draft: 0.000	Speed: 0.000
Entry 2) Draft: 0.000	Speed: 1.000
Entry 3) Draft: 0.000	Speed: 2.400
Entry 4) Draft: 0.000	Speed: 4.500
Entry 5) Draft: 0.000	Speed: 6.000
Entry 6) Draft: 0.000	Speed: 7.500
Entry 7) Draft: 0.000	Speed: 10.000
Entry 8) Draft: 0.000	Speed: 11.500
Entry 9) Draft: 0.000	Speed: 13.000
Entry 10) Draft: 0.000	Speed: 15.000

Svp Sensor:

Time Stamp: 2003-112 00:00

Comments

Svp #1:

Pitch Offset: 0.000

Roll Offset: 0.000

Azimuth Offset: 0.000

DeltaX: 0.000

DeltaY: 0.000

DeltaZ: 0.000

SVP #2:

Pitch Offset: 0.000

Roll Offset: 0.000

Azimuth Offset: 0.000

DeltaX: 0.000

DeltaY: 0.000

DeltaZ: 0.295

WaterLine:

Time Stamp: 2003-112 00:00

Comments

Apply Yes

WaterLine 0.000

WaterLineStdDev 0.000

Vessel Name: 817_Ross950_HVF.hvf
Vessel created: August 31, 2004

Depth Sensor:

Sensor Class: Swath
 Time Stamp: 2004-122 00:00

Transducer #1:

 Pitch Offset: 0.000
 Roll Offset: 0.000
 Azimuth Offset: 0.000

DeltaX: 0.000
 DeltaY: 0.000
 DeltaZ: 0.295

Manufacturer: Ross Laboratories
 Model: ross950
 Serial Number:

Navigation Sensor:

Time Stamp: 2004-122 00:00

Comments
 Latency 0.000
 DeltaX: 0.140
 DeltaY: 0.830
 DeltaZ: -2.300

Manufacturer: (null)
 Model: (null)
 Serial Number: (null)

Draft Sensor:

Time Stamp: 2004-122 00:00

Apply Yes
 Comments

Entry 1) Draft: 0.000	Speed: 0.000
Entry 2) Draft: -0.010	Speed: 1.000
Entry 3) Draft: 0.000	Speed: 2.400
Entry 4) Draft: 0.050	Speed: 4.500
Entry 5) Draft: 0.110	Speed: 6.000
Entry 6) Draft: 0.170	Speed: 7.500
Entry 7) Draft: 0.160	Speed: 10.000
Entry 8) Draft: 0.130	Speed: 11.500
Entry 9) Draft: 0.080	Speed: 13.000
Entry 10) Draft: 0.000	Speed: 15.000

Time Stamp: 2004-214 00:01

Comments S.Allen
Offsets

Motion sensing unit to the transducer 1

X Head 1 0.000

Y Head 1 0.000

Z Head 1 0.000

Motion sensing unit to the transducer 2

X Head 2 0.000

Y Head 2 0.000

Z Head 2 0.000

Navigation antenna to the transducer 1

X Head 1 0.000

Y Head 1 0.000

Z Head 1 0.000

Navigation antenna to the transducer 2

X Head 2 0.000

Y Head 2 0.000

Z Head 2 0.000

Roll offset of transducer number 1 0.000

Roll offset of transducer number 2 0.000

Heave Error: 0.000 or 0.000" of heave amplitude.

Measurement errors: 0.020

Motion sensing unit alignment errors

Gyro:0.000 Pitch:0.000 Roll:0.000

Gyro measurement error: 0.000

Roll measurement error: 0.000

Pitch measurement error: 0.000

Navigation measurement error: 0.000

Transducer timing error: 0.000

Navigation timing error: 0.700

Gyro timing error: 0.000

Heave timing error: 0.000

PitchTimingStdDev: 0.000

Roll timing error: 0.000

Sound Velocity speed measurement error: 0.500

Surface sound speed measurement error: 0.000

Tide measurement error: 0.010

Tide zoning error: 0.200

Speed over ground measurement error: 0.030

Dynamic loading measurement error: 0.030

Static draft measurement error: 0.050

Delta draft measurement error: 0.010

Svp Sensor:

Time Stamp: 2004-122 00:00

Comments

Svp #1:

Pitch Offset: 0.000

Roll Offset: 0.000

Azimuth Offset: 0.000

DeltaX: 0.000
DeltaY: 0.000
DeltaZ: 0.000

SVP #2:

Pitch Offset: 0.000
Roll Offset: 0.000
Azimuth Offset: 0.000

DeltaX: 0.000
DeltaY: 0.000
DeltaZ: 0.295

WaterLine:

Time Stamp: 2004-122 00:00

Comments

Apply Yes

WaterLine 0.000

WaterLineStdDev 0.000

Appendix IV

Calibration Reports

- **SWMB QC Reports**
 - **Lead Line**
- **Sound Velocity Profiler**

1021_Reson8101

Quality Control Report for file : C:\Temp\2004Patch\1021\1021_checkline

Elevation Range is : -38.036 (m) -7.867 (m)

Total number of 3D points used: 163338

Starting Time: 16-MAR-2004 20:33:01.83

Ending Time: 16-MAR-2004 20:40:48.98

Minimum tidal reduction: 0 (mm)

Maximum tidal reduction: 0 (mm)

User#	Total	Max(+)	Max(-)	Mean	Std.	3dm(%)	5dm(%)	1%(%)	1.6%(%)
=====	=====	=====	=====	=====	=====	=====	=====	=====	=====
1	878	1.479	-2.581	-0.021	0.2356	89.6	95.4	71.9	83.9
2	1120	1.444	-1.354	0.014	0.2287	89.6	94.8	74.9	87.3
3	1298	1.197	-1.754	0.024	0.1816	91.7	96.9	78.4	92.7
4	1407	0.937	-1.993	0.019	0.1588	94.1	97.9	83.9	94.2
5	1487	0.968	-0.763	0.014	0.1362	95.8	98.3	84.8	95.6
6	1565	0.948	-0.659	0.012	0.1294	96.4	98.9	84.3	95.3
7	1623	0.871	-0.700	0.013	0.1232	96.2	98.9	84.7	95.0
8	1640	1.098	-0.709	0.015	0.1176	96.5	99.4	84.8	94.0
9	1650	0.659	-0.385	0.016	0.1090	97.8	99.6	85.5	94.4
10	1650	0.631	-0.347	0.021	0.1078	97.9	99.6	85.3	93.6
11	1651	0.659	-0.630	0.024	0.1057	98.2	99.6	86.5	94.4
12	1654	0.610	-0.362	0.026	0.1074	97.9	99.6	86.4	94.4
13	1657	0.532	-0.355	0.023	0.1123	97.6	99.8	85.9	94.3
14	1657	0.478	-0.337	0.025	0.1135	97.6	100.0	86.1	94.0
15	1656	0.477	-0.320	0.027	0.1114	97.8	100.0	85.6	94.2
16	1658	0.527	-0.365	0.029	0.1103	97.5	99.9	86.2	94.7
17	1657	0.467	-0.360	0.031	0.1092	96.9	100.0	85.3	95.0
18	1660	0.465	-0.406	0.031	0.1099	97.1	100.0	85.2	95.2
19	1659	0.513	-0.415	0.032	0.1096	96.9	99.9	86.0	95.5
20	1660	0.460	-0.470	0.032	0.1108	96.4	100.0	85.2	96.0
21	1662	0.459	-0.485	0.032	0.1110	96.8	100.0	84.8	96.3
22	1665	0.431	-0.479	0.034	0.1117	96.9	100.0	84.0	96.1
23	1666	0.442	-0.508	0.033	0.1129	96.9	99.9	83.3	96.6
24	1666	0.375	-0.522	0.032	0.1151	96.7	99.8	83.3	96.9
25	1666	0.399	-0.553	0.031	0.1136	97.4	99.8	83.7	96.8
26	1666	0.394	-0.560	0.031	0.1143	97.5	99.6	83.0	96.6
27	1665	0.379	-0.593	0.031	0.1150	97.4	99.5	82.9	96.4
28	1666	0.363	-0.625	0.029	0.1167	97.0	99.6	82.6	95.9
29	1666	0.388	-0.616	0.027	0.1185	96.7	99.5	82.2	95.4
30	1666	0.546	-0.622	0.026	0.1208	96.7	99.3	81.0	95.6
31	1666	0.592	-0.614	0.027	0.1222	96.4	99.3	80.7	95.6
32	1666	0.629	-0.602	0.028	0.1239	96.5	99.3	80.3	94.8
33	1666	0.629	-0.581	0.027	0.1248	96.3	99.4	80.7	94.9
34	1666	0.480	-0.647	0.025	0.1256	96.4	99.3	80.9	94.9
35	1666	0.519	-0.623	0.026	0.1262	96.5	99.2	79.8	94.7
36	1666	0.598	-0.637	0.027	0.1266	96.5	99.0	79.8	93.6
37	1666	0.595	-0.617	0.027	0.1276	96.3	98.9	80.1	93.8
38	1666	0.542	-0.667	0.028	0.1298	96.2	98.9	78.4	93.5
39	1666	0.565	-0.631	0.030	0.1310	96.2	98.8	77.8	93.1
40	1666	0.586	-0.601	0.029	0.1305	95.9	98.7	78.6	93.2
41	1666	0.610	-0.609	0.030	0.1324	95.7	98.6	78.2	92.7
42	1666	0.620	-0.714	0.032	0.1351	95.6	98.7	77.6	92.5
43	1666	0.593	-0.628	0.031	0.1331	95.7	98.4	78.4	92.6
44	1666	0.649	-0.631	0.033	0.1347	95.4	98.3	77.2	92.6
45	1666	0.667	-0.667	0.033	0.1347	95.5	98.4	77.4	91.8
46	1666	0.644	-0.679	0.032	0.1365	95.2	98.3	77.4	92.1
47	1666	0.628	-0.708	0.034	0.1343	95.2	98.6	77.9	92.0
48	1666	0.631	-0.691	0.035	0.1331	95.4	98.6	78.2	92.1
49	1666	0.635	-0.687	0.036	0.1326	95.4	98.6	77.5	92.3
50	1665	0.608	-0.693	0.037	0.1315	95.3	98.8	77.9	91.8
51	1664	0.605	-0.670	0.039	0.1307	95.4	98.9	77.5	92.1

52	1665	0.599	-0.648	0.039	0.1293	95.4	99.0	78.0	92.4
53	1665	0.602	-0.699	0.039	0.1306	95.7	98.9	78.1	92.6
54	1666	0.588	-0.702	0.039	0.1298	95.2	99.0	78.2	92.5
55	1665	0.585	-0.785	0.038	0.1305	95.6	99.1	78.4	92.8
56	1665	0.565	-0.800	0.037	0.1303	95.4	99.1	78.3	92.4
57	1666	0.577	-0.772	0.037	0.1300	95.3	98.9	78.3	92.7
58	1666	0.564	-0.745	0.038	0.1301	95.5	98.8	78.3	92.4
59	1666	0.600	-0.718	0.037	0.1295	95.7	98.9	78.7	92.5
60	1666	0.646	-0.716	0.037	0.1272	95.4	98.9	79.2	92.7
61	1666	0.643	-0.748	0.036	0.1285	95.8	98.9	79.2	93.2
62	1666	0.630	-0.712	0.035	0.1278	95.9	98.8	80.3	93.4
63	1666	0.667	-0.791	0.034	0.1288	96.3	98.7	79.3	93.2
64	1666	0.601	-0.745	0.033	0.1285	95.7	98.9	81.4	92.9
65	1666	0.612	-0.724	0.033	0.1249	95.7	98.9	82.2	93.6
66	1666	0.649	-0.681	0.032	0.1250	95.8	99.0	82.3	93.7
67	1666	0.579	-0.709	0.031	0.1251	96.0	99.1	80.7	93.9
68	1666	0.557	-0.659	0.030	0.1240	95.4	99.1	80.6	94.2
69	1666	0.538	-0.687	0.029	0.1233	95.7	99.3	80.9	94.1
70	1666	0.480	-0.755	0.029	0.1225	95.7	99.5	81.6	94.2
71	1666	0.484	-0.625	0.028	0.1200	95.7	99.5	80.8	94.1
72	1666	0.447	-0.653	0.028	0.1204	95.6	99.6	81.6	94.4
73	1666	0.453	-0.615	0.028	0.1178	95.9	99.6	83.0	94.9
74	1666	0.422	-0.565	0.030	0.1164	96.0	99.7	83.3	95.0
75	1666	0.410	-0.529	0.029	0.1153	96.0	99.9	83.7	95.3
76	1666	0.429	-0.591	0.027	0.1146	96.2	99.9	84.5	95.7
77	1666	0.424	-0.521	0.026	0.1130	96.6	99.9	84.8	95.9
78	1665	0.430	-0.547	0.025	0.1140	96.3	99.8	85.9	95.7
79	1666	0.430	-0.501	0.025	0.1138	96.3	99.9	86.2	95.4
80	1666	0.451	-0.475	0.023	0.1143	96.2	100.0	87.0	95.6
81	1665	0.445	-0.431	0.021	0.1153	95.9	100.0	86.2	96.0
82	1666	0.446	-0.509	0.016	0.1191	95.7	99.9	86.2	95.7
83	1666	0.463	-0.768	0.012	0.1270	95.1	99.6	85.2	95.5
84	1666	0.453	-0.821	0.009	0.1354	94.5	99.1	85.2	95.0
85	1659	0.474	-0.942	0.007	0.1432	94.2	99.0	85.0	94.5
86	1661	0.478	-1.060	0.001	0.1469	94.2	98.7	85.2	94.8
87	1649	0.476	-1.138	0.002	0.1405	94.6	98.8	85.4	95.0
88	1648	0.457	-1.313	-0.003	0.1593	94.5	98.4	85.3	94.4
89	1645	0.446	-1.346	0.001	0.1497	94.4	98.9	85.7	94.9
90	1640	0.434	-1.378	0.000	0.1505	94.2	99.0	85.3	95.0
91	1631	0.442	-1.405	-0.004	0.1580	94.5	98.7	84.2	95.3
92	1623	0.423	-1.312	-0.012	0.1664	94.0	98.5	83.5	95.2
93	1609	0.443	-1.161	-0.013	0.1532	94.3	98.7	84.6	95.2
94	1596	0.464	-1.133	-0.020	0.1509	94.2	98.4	86.2	94.3
95	1576	0.483	-0.835	-0.026	0.1428	94.4	98.4	84.5	93.3
96	1519	0.528	-1.228	-0.023	0.1389	93.5	98.9	85.4	95.3
97	1474	0.549	-0.857	-0.027	0.1362	93.8	98.6	87.3	95.7
98	1436	1.230	-0.874	-0.022	0.1359	94.4	98.7	87.4	96.2
99	1345	0.699	-1.132	-0.020	0.1283	95.4	98.7	89.1	95.8
100	1181	0.849	-1.164	-0.010	0.1363	96.3	99.0	89.5	96.2
101	950	1.335	-1.616	-0.017	0.1937	91.5	96.3	82.1	91.6

Classification report 1 of 3

IHO statistics a/b are : 0.250 0.008

User#	Total	# fail	% fail	# pass	% pass
=====	=====	=====	=====	=====	=====
1	878	100	11.39	778	88.61
2	1120	124	11.07	996	88.93
3	1298	106	8.17	1192	91.83
4	1407	85	6.04	1322	93.96
5	1487	69	4.64	1418	95.36
6	1565	56	3.58	1509	96.42
7	1623	56	3.45	1567	96.55
8	1640	58	3.54	1582	96.46
9	1650	43	2.61	1607	97.39
10	1650	38	2.30	1612	97.70
11	1651	39	2.36	1612	97.64
12	1654	49	2.96	1605	97.04
13	1657	48	2.90	1609	97.10
14	1657	44	2.66	1613	97.34
15	1656	42	2.54	1614	97.46
16	1658	47	2.83	1611	97.17
17	1657	53	3.20	1604	96.80
18	1660	52	3.13	1608	96.87
19	1659	54	3.25	1605	96.75
20	1660	56	3.37	1604	96.63
21	1662	59	3.55	1603	96.45
22	1665	55	3.30	1610	96.70
23	1666	49	2.94	1617	97.06
24	1666	55	3.30	1611	96.70
25	1666	47	2.82	1619	97.18
26	1666	41	2.46	1625	97.54
27	1665	44	2.64	1621	97.36
28	1666	51	3.06	1615	96.94
29	1666	55	3.30	1611	96.70
30	1666	57	3.42	1609	96.58
31	1666	58	3.48	1608	96.52
32	1666	57	3.42	1609	96.58
33	1666	58	3.48	1608	96.52
34	1666	55	3.30	1611	96.70
35	1666	58	3.48	1608	96.52
36	1666	58	3.48	1608	96.52
37	1666	57	3.42	1609	96.58
38	1666	65	3.90	1601	96.10
39	1666	66	3.96	1600	96.04
40	1666	74	4.44	1592	95.56
41	1666	75	4.50	1591	95.50
42	1666	80	4.80	1586	95.20
43	1666	78	4.68	1588	95.32
44	1666	77	4.62	1589	95.38
45	1666	79	4.74	1587	95.26
46	1666	84	5.04	1582	94.96
47	1666	80	4.80	1586	95.20
48	1666	85	5.10	1581	94.90
49	1666	76	4.56	1590	95.44
50	1665	89	5.35	1576	94.65
51	1664	91	5.47	1573	94.53
52	1665	93	5.59	1572	94.41
53	1665	87	5.23	1578	94.77
54	1666	93	5.58	1573	94.42
55	1665	95	5.71	1570	94.29
56	1665	100	6.01	1565	93.99
57	1666	93	5.58	1573	94.42
58	1666	96	5.76	1570	94.24
59	1666	96	5.76	1570	94.24
60	1666	95	5.70	1571	94.30
61	1666	90	5.40	1576	94.60

62	1666	88	5.28	1578	94.72
63	1666	85	5.10	1581	94.90
64	1666	85	5.10	1581	94.90
65	1666	81	4.86	1585	95.14
66	1666	78	4.68	1588	95.32
67	1666	73	4.38	1593	95.62
68	1666	79	4.74	1587	95.26
69	1666	80	4.80	1586	95.20
70	1666	75	4.50	1591	95.50
71	1666	75	4.50	1591	95.50
72	1666	80	4.80	1586	95.20
73	1666	72	4.32	1594	95.68
74	1666	67	4.02	1599	95.98
75	1666	65	3.90	1601	96.10
76	1666	66	3.96	1600	96.04
77	1666	57	3.42	1609	96.58
78	1665	60	3.60	1605	96.40
79	1666	63	3.78	1603	96.22
80	1666	64	3.84	1602	96.16
81	1665	66	3.96	1599	96.04
82	1666	66	3.96	1600	96.04
83	1666	78	4.68	1588	95.32
84	1666	86	5.16	1580	94.84
85	1659	92	5.55	1567	94.45
86	1661	93	5.60	1568	94.40
87	1649	87	5.28	1562	94.72
88	1648	90	5.46	1558	94.54
89	1645	89	5.41	1556	94.59
90	1640	89	5.43	1551	94.57
91	1631	87	5.33	1544	94.67
92	1623	91	5.61	1532	94.39
93	1609	87	5.41	1522	94.59
94	1596	87	5.45	1509	94.55
95	1576	86	5.46	1490	94.54
96	1519	88	5.79	1431	94.21
97	1474	85	5.77	1389	94.23
98	1436	75	5.22	1361	94.78
99	1345	58	4.31	1287	95.69
100	1181	53	4.49	1128	95.51
101	950	87	9.16	863	90.84

Classification report 2 of 3

IHO statistics a/b are : 0.500 0.013

User#	Total	# fail	% fail	# pass	% pass
=====	=====	=====	=====	=====	=====
1	878	31	3.53	847	96.47
2	1120	46	4.11	1074	95.89
3	1298	26	2.00	1272	98.00
4	1407	20	1.42	1387	98.58
5	1487	19	1.28	1468	98.72
6	1565	13	0.83	1552	99.17
7	1623	9	0.55	1614	99.45
8	1640	5	0.30	1635	99.70
9	1650	3	0.18	1647	99.82
10	1650	4	0.24	1646	99.76
11	1651	2	0.12	1649	99.88
12	1654	1	0.06	1653	99.94
13	1657	0	0.00	1657	100.00
14	1657	0	0.00	1657	100.00
15	1656	0	0.00	1656	100.00
16	1658	0	0.00	1658	100.00
17	1657	0	0.00	1657	100.00
18	1660	0	0.00	1660	100.00
19	1659	0	0.00	1659	100.00
20	1660	0	0.00	1660	100.00
21	1662	0	0.00	1662	100.00
22	1665	0	0.00	1665	100.00
23	1666	0	0.00	1666	100.00
24	1666	0	0.00	1666	100.00
25	1666	0	0.00	1666	100.00
26	1666	0	0.00	1666	100.00
27	1665	0	0.00	1665	100.00
28	1666	0	0.00	1666	100.00
29	1666	0	0.00	1666	100.00
30	1666	1	0.06	1665	99.94
31	1666	1	0.06	1665	99.94
32	1666	1	0.06	1665	99.94
33	1666	1	0.06	1665	99.94
34	1666	0	0.00	1666	100.00
35	1666	0	0.00	1666	100.00
36	1666	1	0.06	1665	99.94
37	1666	1	0.06	1665	99.94
38	1666	1	0.06	1665	99.94
39	1666	0	0.00	1666	100.00
40	1666	3	0.18	1663	99.82
41	1666	1	0.06	1665	99.94
42	1666	6	0.36	1660	99.64
43	1666	3	0.18	1663	99.82
44	1666	5	0.30	1661	99.70
45	1666	6	0.36	1660	99.64
46	1666	10	0.60	1656	99.40
47	1666	9	0.54	1657	99.46
48	1666	6	0.36	1660	99.64
49	1666	7	0.42	1659	99.58
50	1665	6	0.36	1659	99.64
51	1664	6	0.36	1658	99.64
52	1665	3	0.18	1662	99.82
53	1665	5	0.30	1660	99.70
54	1666	7	0.42	1659	99.58
55	1665	7	0.42	1658	99.58
56	1665	6	0.36	1659	99.64
57	1666	8	0.48	1658	99.52
58	1666	7	0.42	1659	99.58
59	1666	10	0.60	1656	99.40
60	1666	7	0.42	1659	99.58
61	1666	12	0.72	1654	99.28

62	1666	11	0.66	1655	99.34
63	1666	12	0.72	1654	99.28
64	1666	12	0.72	1654	99.28
65	1666	10	0.60	1656	99.40
66	1666	8	0.48	1658	99.52
67	1666	7	0.42	1659	99.58
68	1666	4	0.24	1662	99.76
69	1666	4	0.24	1662	99.76
70	1666	2	0.12	1664	99.88
71	1666	0	0.00	1666	100.00
72	1666	1	0.06	1665	99.94
73	1666	0	0.00	1666	100.00
74	1666	0	0.00	1666	100.00
75	1666	0	0.00	1666	100.00
76	1666	0	0.00	1666	100.00
77	1666	0	0.00	1666	100.00
78	1665	0	0.00	1665	100.00
79	1666	0	0.00	1666	100.00
80	1666	0	0.00	1666	100.00
81	1665	0	0.00	1665	100.00
82	1666	0	0.00	1666	100.00
83	1666	4	0.24	1662	99.76
84	1666	9	0.54	1657	99.46
85	1659	11	0.66	1648	99.34
86	1661	13	0.78	1648	99.22
87	1649	12	0.73	1637	99.27
88	1648	18	1.09	1630	98.91
89	1645	9	0.55	1636	99.45
90	1640	12	0.73	1628	99.27
91	1631	16	0.98	1615	99.02
92	1623	22	1.36	1601	98.64
93	1609	19	1.18	1590	98.82
94	1596	17	1.07	1579	98.93
95	1576	11	0.70	1565	99.30
96	1519	5	0.33	1514	99.67
97	1474	10	0.68	1464	99.32
98	1436	8	0.56	1428	99.44
99	1345	8	0.59	1337	99.41
100	1181	9	0.76	1172	99.24
101	950	23	2.42	927	97.58

Classification report 3 of 3

IHO statistics a/b are : 1.000 0.023

User#	Total	# fail	% fail	# pass	% pass
=====	=====	=====	=====	=====	=====
1	878	6	0.68	872	99.32
2	1120	4	0.36	1116	99.64
3	1298	2	0.15	1296	99.85
4	1407	2	0.14	1405	99.86
5	1487	0	0.00	1487	100.00
6	1565	0	0.00	1565	100.00
7	1623	0	0.00	1623	100.00
8	1640	0	0.00	1640	100.00
9	1650	0	0.00	1650	100.00
10	1650	0	0.00	1650	100.00
11	1651	0	0.00	1651	100.00
12	1654	0	0.00	1654	100.00
13	1657	0	0.00	1657	100.00
14	1657	0	0.00	1657	100.00
15	1656	0	0.00	1656	100.00
16	1658	0	0.00	1658	100.00
17	1657	0	0.00	1657	100.00
18	1660	0	0.00	1660	100.00
19	1659	0	0.00	1659	100.00
20	1660	0	0.00	1660	100.00
21	1662	0	0.00	1662	100.00
22	1665	0	0.00	1665	100.00
23	1666	0	0.00	1666	100.00
24	1666	0	0.00	1666	100.00
25	1666	0	0.00	1666	100.00
26	1666	0	0.00	1666	100.00
27	1665	0	0.00	1665	100.00
28	1666	0	0.00	1666	100.00
29	1666	0	0.00	1666	100.00
30	1666	0	0.00	1666	100.00
31	1666	0	0.00	1666	100.00
32	1666	0	0.00	1666	100.00
33	1666	0	0.00	1666	100.00
34	1666	0	0.00	1666	100.00
35	1666	0	0.00	1666	100.00
36	1666	0	0.00	1666	100.00
37	1666	0	0.00	1666	100.00
38	1666	0	0.00	1666	100.00
39	1666	0	0.00	1666	100.00
40	1666	0	0.00	1666	100.00
41	1666	0	0.00	1666	100.00
42	1666	0	0.00	1666	100.00
43	1666	0	0.00	1666	100.00
44	1666	0	0.00	1666	100.00
45	1666	0	0.00	1666	100.00
46	1666	0	0.00	1666	100.00
47	1666	0	0.00	1666	100.00
48	1666	0	0.00	1666	100.00
49	1666	0	0.00	1666	100.00
50	1665	0	0.00	1665	100.00
51	1664	0	0.00	1664	100.00
52	1665	0	0.00	1665	100.00
53	1665	0	0.00	1665	100.00
54	1666	0	0.00	1666	100.00
55	1665	0	0.00	1665	100.00
56	1665	0	0.00	1665	100.00
57	1666	0	0.00	1666	100.00
58	1666	0	0.00	1666	100.00
59	1666	0	0.00	1666	100.00
60	1666	0	0.00	1666	100.00
61	1666	0	0.00	1666	100.00

62	1666	0	0.00	1666	100.00
63	1666	0	0.00	1666	100.00
64	1666	0	0.00	1666	100.00
65	1666	0	0.00	1666	100.00
66	1666	0	0.00	1666	100.00
67	1666	0	0.00	1666	100.00
68	1666	0	0.00	1666	100.00
69	1666	0	0.00	1666	100.00
70	1666	0	0.00	1666	100.00
71	1666	0	0.00	1666	100.00
72	1666	0	0.00	1666	100.00
73	1666	0	0.00	1666	100.00
74	1666	0	0.00	1666	100.00
75	1666	0	0.00	1666	100.00
76	1666	0	0.00	1666	100.00
77	1666	0	0.00	1666	100.00
78	1665	0	0.00	1665	100.00
79	1666	0	0.00	1666	100.00
80	1666	0	0.00	1666	100.00
81	1665	0	0.00	1665	100.00
82	1666	0	0.00	1666	100.00
83	1666	0	0.00	1666	100.00
84	1666	0	0.00	1666	100.00
85	1659	0	0.00	1659	100.00
86	1661	0	0.00	1661	100.00
87	1649	0	0.00	1649	100.00
88	1648	2	0.12	1646	99.88
89	1645	2	0.12	1643	99.88
90	1640	2	0.12	1638	99.88
91	1631	2	0.12	1629	99.88
92	1623	2	0.12	1621	99.88
93	1609	0	0.00	1609	100.00
94	1596	0	0.00	1596	100.00
95	1576	0	0.00	1576	100.00
96	1519	0	0.00	1519	100.00
97	1474	0	0.00	1474	100.00
98	1436	0	0.00	1436	100.00
99	1345	0	0.00	1345	100.00
100	1181	0	0.00	1181	100.00
101	950	3	0.32	947	99.68

1016_Elac1180

Quality Control Report for file : C:\Temp\2004Patch\1016_Elac\1016_checkline

Elevation Range is : -90.223 (m) -58.388 (m)

Total number of 3D points used: 13466

Starting Time: 16-MAR-2004 22:03:15.98

Ending Time: 16-MAR-2004 22:05:54.97

Minimum tidal reduction: 2359 (mm)

Maximum tidal reduction: 2374 (mm)

User#	Total	Max(+)	Max(-)	Mean	Std.	3dm(%)	5dm(%)	1%(%)	1.6%(%)
=====	=====	=====	=====	=====	=====	=====	=====	=====	=====
14	116	1.630	-3.575	-0.537	0.8767	19.8	35.3	50.0	75.0
15	116	1.872	-2.836	-0.459	0.8498	21.6	35.3	50.0	73.3
16	118	1.191	-3.195	-0.563	0.8155	19.5	37.3	55.1	75.4
17	122	1.797	-2.289	-0.429	0.6744	23.0	41.0	58.2	85.2
18	126	1.461	-1.912	-0.445	0.6662	26.2	40.5	54.0	85.7
19	133	1.446	-1.989	-0.376	0.6749	31.6	50.4	63.9	82.7
20	135	0.962	-1.869	-0.409	0.6299	32.6	50.4	59.3	87.4
21	134	1.462	-1.613	-0.289	0.6102	38.1	53.0	67.9	90.3
22	136	1.457	-1.603	-0.227	0.6230	27.9	53.7	70.6	90.4
23	137	1.695	-1.539	-0.208	0.6677	38.0	54.0	70.1	87.6
24	136	2.132	-1.459	-0.134	0.6372	39.7	61.8	73.5	91.2
25	132	1.388	-1.196	-0.231	0.5055	36.4	57.6	78.8	97.0
26	136	1.950	-1.348	-0.165	0.6074	36.0	59.6	72.1	91.2
27	134	1.771	-1.226	-0.101	0.5747	40.3	66.4	82.1	91.8
28	138	2.155	-1.090	-0.165	0.5607	40.6	63.0	79.7	94.9
29	137	1.949	-1.562	-0.076	0.6135	42.3	66.4	81.0	89.8
30	138	1.887	-0.882	-0.019	0.5381	55.8	71.0	84.8	94.9
31	135	2.081	-1.048	-0.082	0.5688	42.2	65.9	81.5	96.3
32	138	2.195	-0.957	-0.041	0.5409	47.1	71.7	85.5	96.4
33	136	1.759	-1.082	-0.058	0.5372	51.5	69.9	83.1	94.9
34	137	1.708	-1.125	-0.106	0.5161	42.3	70.8	83.9	97.1
35	136	1.340	-0.868	-0.040	0.4614	49.3	77.9	86.0	97.1
36	135	1.187	-1.130	-0.050	0.4954	48.9	68.1	84.4	95.6
37	138	1.360	-0.829	-0.042	0.4641	50.0	74.6	88.4	95.7
38	138	1.506	-0.872	0.075	0.4996	52.2	80.4	84.8	94.2
39	138	1.957	-0.917	0.090	0.5121	58.7	79.7	86.2	94.9
40	137	1.406	-0.852	0.016	0.4514	52.6	78.1	89.8	94.9
41	137	1.320	-0.791	0.059	0.4661	51.1	73.0	84.7	96.4
42	138	1.756	-0.835	0.075	0.4758	56.5	78.3	87.7	95.7
43	137	1.699	-0.636	0.029	0.4206	55.5	83.9	92.7	96.4
44	136	1.586	-1.096	0.082	0.4387	60.3	76.5	86.8	97.1
45	137	1.177	-0.868	0.062	0.3791	64.2	87.6	91.2	97.8
46	138	1.196	-0.811	0.029	0.4059	65.9	84.1	87.0	97.8
47	135	1.332	-1.534	0.088	0.4556	56.3	74.1	88.1	95.6
48	137	1.780	-1.230	0.097	0.4571	52.6	78.8	86.9	96.4
49	136	1.703	-0.788	0.040	0.4295	50.7	80.1	90.4	97.1
50	135	1.423	-1.042	0.000	0.4634	49.6	71.1	86.7	97.8
51	137	1.328	-0.872	0.067	0.4541	50.4	71.5	85.4	98.5
52	135	1.047	-0.960	0.017	0.4218	53.3	76.3	88.9	100.0
53	137	1.265	-0.797	0.054	0.4316	47.4	74.5	89.8	99.3
54	136	1.640	-0.882	0.042	0.4676	47.1	73.5	86.8	97.1
55	137	1.456	-0.890	0.108	0.4753	44.5	67.2	86.1	98.5
56	137	1.597	-0.795	0.167	0.5204	39.4	62.0	83.2	92.7
57	138	1.550	-0.789	0.229	0.5168	40.6	59.4	74.6	94.9
58	138	1.316	-0.976	0.144	0.4892	34.8	69.6	81.9	97.8
59	137	1.436	-1.182	0.140	0.5071	44.5	65.0	78.1	97.1
60	135	1.773	-1.089	0.231	0.5521	43.0	64.4	76.3	92.6
61	134	1.432	-1.120	0.221	0.5531	36.6	55.2	70.9	94.0
62	135	1.680	-0.869	0.229	0.5523	38.5	55.6	70.4	95.6

63	136	1.505	-0.974	0.220	0.5991	33.8	55.9	65.4	93.4
64	136	1.481	-1.434	0.145	0.5930	35.3	58.1	71.3	94.9
65	137	1.169	-1.311	-0.085	0.5661	38.0	58.4	74.5	94.9
66	137	0.963	-1.609	-0.158	0.5993	43.1	59.1	72.3	91.2
67	137	1.357	-1.590	-0.044	0.6571	31.4	53.3	67.2	90.5
68	135	0.962	-1.837	-0.121	0.6534	31.1	53.3	73.3	90.4
69	138	0.844	-1.805	-0.277	0.6100	36.2	58.7	73.2	87.7
70	137	1.153	-1.839	-0.114	0.6154	37.2	56.9	73.7	90.5
71	138	1.086	-1.892	-0.265	0.6268	32.6	55.8	69.6	87.7
72	138	0.866	-2.356	-0.375	0.5776	39.9	59.4	72.5	91.3
73	138	1.245	-1.810	-0.119	0.6036	36.2	57.2	78.3	94.9
74	137	0.826	-1.858	-0.281	0.5877	34.3	58.4	73.0	92.7
75	136	0.708	-2.264	-0.381	0.6102	33.1	52.9	69.9	89.7
76	137	1.310	-2.121	-0.264	0.6310	32.1	55.5	67.9	89.8
77	137	0.836	-2.265	-0.400	0.6518	35.8	51.8	65.0	86.9
78	137	0.614	-2.213	-0.509	0.6340	24.8	51.1	63.5	80.3
79	138	1.018	-2.662	-0.428	0.6823	27.5	47.8	58.7	87.0
80	137	0.738	-2.388	-0.535	0.7060	32.1	48.9	62.0	81.8
81	137	0.830	-2.822	-0.599	0.7191	29.2	42.3	54.7	77.4
82	137	0.881	-2.558	-0.522	0.6857	23.4	46.7	56.9	84.7
83	138	0.884	-2.886	-0.654	0.7213	25.4	42.0	50.7	79.7
84	137	0.857	-3.199	-0.729	0.7592	21.9	34.3	50.4	72.3
85	138	0.969	-2.936	-0.682	0.7901	25.4	35.5	47.1	71.7
86	138	0.717	-2.953	-0.801	0.7985	19.6	34.8	43.5	65.9
87	138	0.923	-2.729	-0.817	0.8006	21.7	30.4	42.0	63.8
88	137	1.137	-2.803	-0.711	0.8528	24.1	39.4	48.9	63.5
89	135	1.008	-2.670	-0.801	0.8357	17.8	34.8	44.4	60.7
90	137	1.314	-2.933	-0.908	0.8637	19.7	31.4	41.6	54.7
91	138	1.049	-3.059	-0.825	0.8781	18.8	36.2	47.8	63.0
92	137	1.135	-3.064	-0.827	0.8646	20.4	30.7	46.0	63.5
93	137	1.003	-2.652	-0.937	0.8254	19.7	30.7	38.7	57.7
94	138	0.946	-2.699	-0.838	0.8460	24.6	36.2	44.9	62.3
95	135	1.046	-2.733	-0.838	0.8448	23.0	32.6	43.0	57.0
96	137	1.323	-2.293	-0.866	0.7303	20.4	29.2	37.2	59.1
97	136	1.232	-2.216	-0.746	0.7619	27.2	36.8	41.9	69.9
98	135	0.968	-2.305	-0.832	0.7469	24.4	31.1	37.0	57.8
99	137	0.912	-2.482	-0.874	0.7306	16.8	29.9	38.0	61.3
100	136	1.078	-2.444	-0.774	0.8109	25.7	33.8	39.0	61.8
101	134	0.899	-2.921	-0.941	0.8451	17.9	32.1	41.0	54.5
102	132	0.721	-2.617	-0.973	0.7985	22.0	31.8	38.6	51.5
103	132	0.955	-2.363	-0.917	0.7921	19.7	34.1	40.9	57.6
104	131	0.869	-3.035	-1.083	0.8548	14.5	29.8	36.6	50.4
105	129	0.852	-2.810	-1.140	0.7949	8.5	20.2	34.1	49.6
106	132	0.713	-2.922	-1.120	0.8486	8.3	24.2	36.4	54.5
107	131	0.965	-3.172	-1.243	0.8558	9.9	16.8	24.4	44.3
108	132	0.872	-3.725	-1.338	0.9345	6.8	13.6	23.5	40.2
109	123	0.550	-4.030	-1.254	0.9754	12.2	21.1	27.6	46.3
110	130	0.613	-4.739	-1.456	1.0518	10.0	13.8	19.2	38.5
111	124	0.691	-5.095	-1.520	1.1166	8.1	14.5	21.0	34.7
112	123	0.574	-4.488	-1.549	1.0317	6.5	13.0	17.9	29.3
113	115	0.422	-5.243	-1.691	1.2173	7.0	15.7	20.0	30.4

Classification report 1 of 3

IHO statistics a/b are : 0.250 0.008

User#	Total	# fail	% fail	# pass	% pass
=====	=====	=====	=====	=====	=====
14	116	73	62.93	43	37.07
15	116	68	58.62	48	41.38
16	118	66	55.93	52	44.07
17	122	64	52.46	58	47.54
18	126	66	52.38	60	47.62
19	133	58	43.61	75	56.39
20	135	64	47.41	71	52.59
21	134	55	41.04	79	58.96
22	136	51	37.50	85	62.50
23	137	54	39.42	83	60.58
24	136	49	36.03	87	63.97
25	132	47	35.61	85	64.39
26	136	49	36.03	87	63.97
27	134	37	27.61	97	72.39
28	138	42	30.43	96	69.57
29	137	42	30.66	95	69.34
30	138	28	20.29	110	79.71
31	135	36	26.67	99	73.33
32	138	31	22.46	107	77.54
33	136	37	27.21	99	72.79
34	137	34	24.82	103	75.18
35	136	25	18.38	111	81.62
36	135	34	25.19	101	74.81
37	138	28	20.29	110	79.71
38	138	25	18.12	113	81.88
39	138	24	17.39	114	82.61
40	137	22	16.06	115	83.94
41	137	30	21.90	107	78.10
42	138	25	18.12	113	81.88
43	137	16	11.68	121	88.32
44	136	27	19.85	109	80.15
45	137	14	10.22	123	89.78
46	138	21	15.22	117	84.78
47	135	26	19.26	109	80.74
48	137	24	17.52	113	82.48
49	136	20	14.71	116	85.29
50	135	30	22.22	105	77.78
51	137	29	21.17	108	78.83
52	135	21	15.56	114	84.44
53	137	25	18.25	112	81.75
54	136	27	19.85	109	80.15
55	137	32	23.36	105	76.64
56	137	36	26.28	101	73.72
57	138	48	34.78	90	65.22
58	138	36	26.09	102	73.91
59	137	39	28.47	98	71.53
60	135	40	29.63	95	70.37
61	134	53	39.55	81	60.45
62	135	53	39.26	82	60.74
63	136	56	41.18	80	58.82
64	136	50	36.76	86	63.24
65	137	45	32.85	92	67.15
66	137	52	37.96	85	62.04
67	137	58	42.34	79	57.66
68	135	53	39.26	82	60.74
69	138	45	32.61	93	67.39
70	137	52	37.96	85	62.04
71	138	54	39.13	84	60.87
72	138	52	37.68	86	62.32
73	138	49	35.51	89	64.49
74	137	48	35.04	89	64.96

75	136	57	41.91	79	58.09
76	137	53	38.69	84	61.31
77	137	59	43.07	78	56.93
78	137	62	45.26	75	54.74
79	138	65	47.10	73	52.90
80	137	65	47.45	72	52.55
81	137	74	54.01	63	45.99
82	137	68	49.64	69	50.36
83	138	74	53.62	64	46.38
84	137	82	59.85	55	40.15
85	138	82	59.42	56	40.58
86	138	85	61.59	53	38.41
87	138	92	66.67	46	33.33
88	137	78	56.93	59	43.07
89	135	85	62.96	50	37.04
90	137	85	62.04	52	37.96
91	138	83	60.14	55	39.86
92	137	85	62.04	52	37.96
93	137	92	67.15	45	32.85
94	138	82	59.42	56	40.58
95	135	81	60.00	54	40.00
96	137	92	67.15	45	32.85
97	136	82	60.29	54	39.71
98	135	90	66.67	45	33.33
99	137	90	65.69	47	34.31
100	136	88	64.71	48	35.29
101	134	88	65.67	46	34.33
102	132	88	66.67	44	33.33
103	132	86	65.15	46	34.85
104	131	88	67.18	43	32.82
105	129	98	75.97	31	24.03
106	132	95	71.97	37	28.03
107	131	100	76.34	31	23.66
108	132	109	82.58	23	17.42
109	123	96	78.05	27	21.95
110	130	111	85.38	19	14.62
111	124	104	83.87	20	16.13
112	123	107	86.99	16	13.01
113	115	95	82.61	20	17.39

Classification report 2 of 3

IHO statistics a/b are : 0.500 0.013

User#	Total	# fail	% fail	# pass	% pass
=====	=====	=====	=====	=====	=====
14	116	34	29.31	82	70.69
15	116	32	27.59	84	72.41
16	118	35	29.66	83	70.34
17	122	24	19.67	98	80.33
18	126	31	24.60	95	75.40
19	133	28	21.05	105	78.95
20	135	24	17.78	111	82.22
21	134	16	11.94	118	88.06
22	136	18	13.24	118	86.76
23	137	22	16.06	115	83.94
24	136	17	12.50	119	87.50
25	132	6	4.55	126	95.45
26	136	13	9.56	123	90.44
27	134	12	8.96	122	91.04
28	138	8	5.80	130	94.20
29	137	14	10.22	123	89.78
30	138	7	5.07	131	94.93
31	135	8	5.93	127	94.07
32	138	5	3.62	133	96.38
33	136	10	7.35	126	92.65
34	137	7	5.11	130	94.89
35	136	4	2.94	132	97.06
36	135	8	5.93	127	94.07
37	138	7	5.07	131	94.93
38	138	10	7.25	128	92.75
39	138	10	7.25	128	92.75
40	137	7	5.11	130	94.89
41	137	5	3.65	132	96.35
42	138	7	5.07	131	94.93
43	137	5	3.65	132	96.35
44	136	6	4.41	130	95.59
45	137	5	3.65	132	96.35
46	138	4	2.90	134	97.10
47	135	6	4.44	129	95.56
48	137	6	4.38	131	95.62
49	136	4	2.94	132	97.06
50	135	5	3.70	130	96.30
51	137	3	2.19	134	97.81
52	135	0	0.00	135	100.00
53	137	2	1.46	135	98.54
54	136	4	2.94	132	97.06
55	137	5	3.65	132	96.35
56	137	10	7.30	127	92.70
57	138	7	5.07	131	94.93
58	138	6	4.35	132	95.65
59	137	5	3.65	132	96.35
60	135	11	8.15	124	91.85
61	134	10	7.46	124	92.54
62	135	7	5.19	128	94.81
63	136	11	8.09	125	91.91
64	136	14	10.29	122	89.71
65	137	12	8.76	125	91.24
66	137	15	10.95	122	89.05
67	137	16	11.68	121	88.32
68	135	16	11.85	119	88.15
69	138	18	13.04	120	86.96
70	137	15	10.95	122	89.05
71	138	20	14.49	118	85.51
72	138	18	13.04	120	86.96
73	138	11	7.97	127	92.03
74	137	14	10.22	123	89.78

75	136	18	13.24	118	86.76
76	137	15	10.95	122	89.05
77	137	22	16.06	115	83.94
78	137	27	19.71	110	80.29
79	138	24	17.39	114	82.61
80	137	30	21.90	107	78.10
81	137	35	25.55	102	74.45
82	137	27	19.71	110	80.29
83	138	37	26.81	101	73.19
84	137	49	35.77	88	64.23
85	138	42	30.43	96	69.57
86	138	55	39.86	83	60.14
87	138	58	42.03	80	57.97
88	137	55	40.15	82	59.85
89	135	56	41.48	79	58.52
90	137	64	46.72	73	53.28
91	138	56	40.58	82	59.42
92	137	56	40.88	81	59.12
93	137	65	47.45	72	52.55
94	138	58	42.03	80	57.97
95	135	59	43.70	76	56.30
96	137	63	45.99	74	54.01
97	136	54	39.71	82	60.29
98	135	64	47.41	71	52.59
99	137	67	48.91	70	51.09
100	136	60	44.12	76	55.88
101	134	69	51.49	65	48.51
102	132	68	51.52	64	48.48
103	132	64	48.48	68	51.52
104	131	70	53.44	61	46.56
105	129	69	53.49	60	46.51
106	132	64	48.48	68	51.52
107	131	78	59.54	53	40.46
108	132	79	59.85	53	40.15
109	123	68	55.28	55	44.72
110	130	81	62.31	49	37.69
111	124	86	69.35	38	30.65
112	123	93	75.61	30	24.39
113	115	84	73.04	31	26.96

Classification report 3 of 3

IHO statistics a/b are : 1.000 0.023

User#	Total	# fail	% fail	# pass	% pass
=====	=====	=====	=====	=====	=====
14	116	3	2.59	113	97.41
15	116	3	2.59	113	97.41
16	118	4	3.39	114	96.61
17	122	1	0.82	121	99.18
18	126	1	0.79	125	99.21
19	133	0	0.00	133	100.00
20	135	1	0.74	134	99.26
21	134	0	0.00	134	100.00
22	136	0	0.00	136	100.00
23	137	0	0.00	137	100.00
24	136	1	0.74	135	99.26
25	132	0	0.00	132	100.00
26	136	1	0.74	135	99.26
27	134	0	0.00	134	100.00
28	138	1	0.72	137	99.28
29	137	1	0.73	136	99.27
30	138	0	0.00	138	100.00
31	135	1	0.74	134	99.26
32	138	2	1.45	136	98.55
33	136	0	0.00	136	100.00
34	137	0	0.00	137	100.00
35	136	0	0.00	136	100.00
36	135	0	0.00	135	100.00
37	138	0	0.00	138	100.00
38	138	0	0.00	138	100.00
39	138	1	0.72	137	99.28
40	137	0	0.00	137	100.00
41	137	0	0.00	137	100.00
42	138	0	0.00	138	100.00
43	137	0	0.00	137	100.00
44	136	0	0.00	136	100.00
45	137	0	0.00	137	100.00
46	138	0	0.00	138	100.00
47	135	0	0.00	135	100.00
48	137	0	0.00	137	100.00
49	136	0	0.00	136	100.00
50	135	0	0.00	135	100.00
51	137	0	0.00	137	100.00
52	135	0	0.00	135	100.00
53	137	0	0.00	137	100.00
54	136	0	0.00	136	100.00
55	137	0	0.00	137	100.00
56	137	0	0.00	137	100.00
57	138	0	0.00	138	100.00
58	138	0	0.00	138	100.00
59	137	0	0.00	137	100.00
60	135	0	0.00	135	100.00
61	134	0	0.00	134	100.00
62	135	0	0.00	135	100.00
63	136	0	0.00	136	100.00
64	136	0	0.00	136	100.00
65	137	0	0.00	137	100.00
66	137	0	0.00	137	100.00
67	137	0	0.00	137	100.00
68	135	0	0.00	135	100.00
69	138	0	0.00	138	100.00
70	137	1	0.73	136	99.27
71	138	1	0.72	137	99.28
72	138	3	2.17	135	97.83
73	138	0	0.00	138	100.00
74	137	0	0.00	137	100.00

75	136	3	2.21	133	97.79
76	137	2	1.46	135	98.54
77	137	4	2.92	133	97.08
78	137	5	3.65	132	96.35
79	138	5	3.62	133	96.38
80	137	7	5.11	130	94.89
81	137	6	4.38	131	95.62
82	137	5	3.65	132	96.35
83	138	8	5.80	130	94.20
84	137	8	5.84	129	94.16
85	138	10	7.25	128	92.75
86	138	10	7.25	128	92.75
87	138	13	9.42	125	90.58
88	137	12	8.76	125	91.24
89	135	13	9.63	122	90.37
90	137	17	12.41	120	87.59
91	138	14	10.14	124	89.86
92	137	16	11.68	121	88.32
93	137	19	13.87	118	86.13
94	138	12	8.70	126	91.30
95	135	17	12.59	118	87.41
96	137	7	5.11	130	94.89
97	136	7	5.15	129	94.85
98	135	8	5.93	127	94.07
99	137	8	5.84	129	94.16
100	136	11	8.09	125	91.91
101	134	13	9.70	121	90.30
102	132	17	12.88	115	87.12
103	132	14	10.61	118	89.39
104	131	23	17.56	108	82.44
105	129	23	17.83	106	82.17
106	132	29	21.97	103	78.03
107	131	33	25.19	98	74.81
108	132	36	27.27	96	72.73
109	123	28	22.76	95	77.24
110	130	35	26.92	95	73.08
111	124	33	26.61	91	73.39
112	123	36	29.27	87	70.73
113	115	43	37.39	72	62.61

1016_Reson8125

Quality Control Report for file :
 C:\Temp\2004Patch\1016_neg1pt5yaw\1016_checkline

Elevation Range is : -36.030(m) -8.777(m)

Total number of 3D points used: 572448

Starting Time: 15-MAR-2004 21:32:54.75
 Ending Time: 15-MAR-2004 21:42:52.76

Minimum tidal reduction: 0 (mm)
 Maximum tidal reduction: 0 (mm)

User#	Total	Max(+)	Max(-)	Mean	Std.	3dm(%)	5dm(%)	1%(%)	1.6%(%)
1	1685	0.957	-0.650	0.118	0.2439	73.3	93.9	53.4	72.4
2	1727	0.946	-0.621	0.118	0.2387	73.2	94.4	54.3	72.6
3	1774	0.912	-0.564	0.114	0.2331	74.5	94.8	56.5	74.0
4	1802	0.905	-0.570	0.115	0.2301	75.1	95.0	57.3	74.3
5	1831	0.902	-0.572	0.111	0.2283	75.5	94.8	57.8	75.2
6	1864	0.882	-0.589	0.111	0.2267	75.7	94.4	58.1	75.9
7	1911	0.879	-0.567	0.113	0.2275	75.9	93.6	59.7	75.7
8	1929	0.931	-0.585	0.113	0.2259	76.4	93.7	60.3	74.8
9	1948	0.891	-0.594	0.114	0.2238	76.4	93.9	60.5	74.6
10	1978	0.886	-0.589	0.113	0.2215	77.1	94.1	60.2	74.6
11	2001	0.909	-0.572	0.114	0.2183	78.0	94.1	59.8	74.4
12	2011	0.863	-0.571	0.113	0.2165	78.4	94.0	60.0	74.8
13	2024	0.947	-0.563	0.112	0.2149	79.0	94.3	60.1	75.6
14	2054	0.909	-0.561	0.108	0.2128	80.0	94.4	61.7	76.3
15	2062	0.876	-0.565	0.108	0.2103	80.3	94.3	62.5	77.0
16	2080	0.867	-0.547	0.109	0.2090	80.5	94.1	63.2	77.0
17	2112	0.842	-0.555	0.107	0.2064	81.0	94.4	63.5	77.6
18	2118	0.850	-0.571	0.105	0.2050	80.7	94.1	64.0	77.7
19	2131	0.829	-0.550	0.106	0.2039	80.7	94.4	64.4	77.9
20	2183	0.834	-0.532	0.103	0.2019	81.3	94.4	65.2	78.8
21	2193	0.840	-0.526	0.103	0.2019	80.7	94.5	65.8	78.8
22	2204	0.820	-0.528	0.101	0.2018	80.6	94.4	65.8	78.9
23	2214	0.816	-0.515	0.102	0.2010	80.9	94.7	65.4	78.5
24	2242	0.824	-0.505	0.099	0.1997	81.0	94.8	66.5	79.3
25	2255	0.794	-0.528	0.096	0.1987	81.5	94.9	66.4	79.2
26	2260	0.772	-0.525	0.095	0.1977	81.6	94.8	67.2	79.4
27	2271	0.790	-0.534	0.095	0.1974	81.4	94.9	67.4	79.4
28	2295	0.781	-0.501	0.095	0.1977	81.2	95.2	67.1	79.5
29	2298	0.755	-0.502	0.092	0.1968	81.9	95.4	67.6	80.0
30	2305	0.738	-0.523	0.091	0.1955	82.0	95.4	67.4	79.7
31	2314	0.722	-0.529	0.089	0.1939	82.0	95.8	68.0	80.4
32	2332	0.703	-0.551	0.089	0.1936	82.6	95.9	68.7	80.2
33	2338	0.702	-0.496	0.087	0.1918	83.1	96.2	68.0	80.7
34	2348	0.673	-0.556	0.085	0.1909	83.3	96.2	69.3	81.0
35	2353	0.674	-0.514	0.084	0.1903	83.3	96.5	68.4	81.0
36	2357	0.679	-0.542	0.083	0.1895	83.8	96.4	68.9	81.2
37	2373	0.652	-0.497	0.081	0.1883	84.1	96.8	69.4	81.6
38	2379	0.668	-0.581	0.079	0.1873	84.3	96.6	69.7	81.7
39	2385	0.777	-0.505	0.077	0.1868	84.2	96.8	70.2	82.1
40	2389	0.737	-0.514	0.074	0.1867	84.9	96.8	70.3	82.4
41	2394	0.733	-0.523	0.072	0.1853	85.5	96.8	70.1	82.7
42	2411	0.655	-0.519	0.070	0.1836	85.1	96.9	70.5	83.2
43	2423	0.652	-0.530	0.067	0.1841	85.5	97.0	70.6	83.5
44	2426	0.638	-0.570	0.064	0.1818	86.1	96.9	71.2	84.2
45	2429	0.654	-0.549	0.063	0.1809	85.9	97.3	71.4	83.9
46	2439	0.617	-0.612	0.061	0.1800	85.9	97.1	71.3	83.5
47	2444	0.626	-0.539	0.060	0.1793	86.3	97.4	70.3	83.8
48	2457	0.631	-0.517	0.057	0.1777	86.5	97.5	72.4	84.2
49	2473	0.631	-0.530	0.057	0.1770	86.9	97.5	72.4	84.3
50	2475	0.643	-0.519	0.056	0.1760	87.4	97.6	72.5	84.4

51	2477	0.625	-0.547	0.055	0.1750	87.8	97.7	72.9	84.8
52	2484	0.634	-0.527	0.053	0.1740	88.2	97.5	73.5	84.7
53	2503	0.621	-0.554	0.053	0.1723	88.1	97.6	73.8	85.2
54	2506	0.610	-0.574	0.051	0.1728	88.4	97.7	73.9	85.0
55	2506	0.645	-0.559	0.050	0.1723	88.8	97.5	73.8	85.3
56	2513	0.617	-0.544	0.049	0.1718	88.9	97.5	75.0	85.6
57	2515	0.612	-0.555	0.047	0.1715	89.3	97.7	74.7	85.4
58	2525	0.619	-0.537	0.047	0.1701	89.6	97.5	75.2	85.9
59	2524	0.639	-0.547	0.044	0.1696	89.5	97.6	75.0	85.5
60	2521	0.643	-0.577	0.043	0.1695	89.7	97.6	75.5	85.6
61	2521	0.644	-0.585	0.042	0.1698	89.8	97.7	75.7	85.9
62	2518	0.638	-0.538	0.041	0.1691	90.1	97.6	76.1	86.3
63	2518	0.650	-0.543	0.038	0.1683	90.1	97.9	75.9	85.8
64	2517	0.676	-0.536	0.038	0.1686	90.1	97.8	75.8	85.9
65	2514	0.658	-0.529	0.038	0.1680	90.2	97.7	75.9	86.6
66	2514	0.704	-0.566	0.036	0.1686	90.1	97.8	75.5	86.5
67	2511	0.722	-0.545	0.035	0.1690	90.0	97.9	75.5	86.4
68	2510	0.684	-0.515	0.035	0.1691	90.2	97.6	75.7	86.4
69	2513	0.710	-0.516	0.034	0.1683	90.7	97.8	75.9	87.0
70	2516	0.741	-0.551	0.033	0.1696	90.9	97.6	75.8	86.5
71	2515	0.711	-0.539	0.033	0.1705	90.2	97.6	75.7	86.9
72	2516	0.731	-0.483	0.032	0.1705	90.5	97.8	74.9	86.8
73	2517	0.724	-0.477	0.032	0.1707	90.5	97.7	75.1	86.8
74	2517	0.766	-0.463	0.032	0.1711	90.1	97.7	75.0	86.8
75	2518	0.801	-0.475	0.031	0.1709	90.5	97.7	75.6	86.9
76	2520	0.761	-0.459	0.032	0.1725	89.9	97.6	74.4	86.6
77	2519	0.779	-0.455	0.032	0.1735	90.0	97.6	75.1	86.9
78	2522	0.760	-0.469	0.030	0.1736	89.8	97.4	75.0	86.6
79	2522	0.800	-0.489	0.030	0.1747	89.8	97.5	74.8	86.6
80	2521	0.816	-0.469	0.029	0.1751	90.1	97.4	74.9	86.8
81	2523	0.841	-0.452	0.029	0.1763	89.6	97.5	73.9	86.7
82	2524	0.849	-0.475	0.028	0.1766	89.8	97.5	74.3	86.8
83	2523	0.856	-0.456	0.028	0.1766	89.9	97.5	74.2	86.3
84	2521	0.804	-0.460	0.028	0.1768	89.6	97.5	75.2	86.4
85	2523	0.846	-0.454	0.029	0.1768	89.3	97.5	75.1	86.4
86	2525	0.833	-0.466	0.029	0.1772	89.2	97.3	75.4	86.0
87	2524	0.831	-0.497	0.029	0.1789	89.3	97.3	74.4	86.1
88	2523	0.860	-0.453	0.029	0.1794	89.3	97.3	74.7	86.2
89	2523	0.833	-0.425	0.028	0.1799	88.9	97.5	74.9	86.2
90	2524	0.823	-0.433	0.027	0.1810	88.9	97.4	74.3	86.4
91	2523	0.824	-0.443	0.027	0.1802	89.2	97.3	74.2	86.4
92	2528	0.808	-0.471	0.027	0.1812	88.8	97.1	74.5	86.2
93	2529	0.843	-0.451	0.028	0.1815	89.0	97.2	74.9	86.4
94	2528	0.814	-0.457	0.027	0.1818	88.9	97.1	74.5	86.4
95	2522	0.825	-0.449	0.028	0.1822	88.7	97.1	74.5	86.4
96	2529	0.835	-0.463	0.028	0.1834	88.8	97.0	73.8	86.2
97	2528	0.835	-0.455	0.027	0.1834	88.7	97.1	74.3	85.8
98	2530	0.827	-0.457	0.026	0.1840	88.8	97.2	74.0	86.1
99	2531	0.764	-0.459	0.026	0.1840	88.7	97.2	74.0	86.1
100	2535	0.871	-0.493	0.025	0.1840	88.8	97.3	73.9	86.2
101	2529	0.789	-0.507	0.025	0.1843	88.7	97.1	73.6	85.8
102	2533	0.768	-0.505	0.023	0.1849	88.7	97.2	74.4	86.1
103	2533	0.831	-0.482	0.022	0.1849	89.0	97.4	74.5	86.4
104	2534	0.781	-0.528	0.022	0.1844	88.9	97.2	74.8	86.2
105	2534	0.767	-0.476	0.021	0.1839	89.0	97.4	74.7	86.0
106	2532	0.775	-0.519	0.020	0.1861	88.9	97.2	74.7	86.1
107	2525	0.762	-0.511	0.021	0.1842	89.2	97.3	75.0	85.8
108	2531	0.782	-0.499	0.021	0.1846	89.3	97.4	74.9	86.4
109	2530	0.770	-0.490	0.020	0.1849	88.8	97.4	74.0	86.1
110	2530	0.767	-0.503	0.020	0.1847	88.8	97.3	74.5	86.1
111	2529	0.764	-0.506	0.021	0.1846	89.0	97.0	75.3	86.1
112	2523	0.744	-0.507	0.022	0.1840	89.2	97.1	74.5	86.0
113	2526	0.744	-0.506	0.021	0.1845	89.2	97.1	75.1	86.0
114	2527	0.745	-0.519	0.022	0.1836	89.1	97.0	74.9	86.1
115	2525	0.778	-0.530	0.022	0.1844	89.1	97.1	74.9	86.0
116	2527	0.784	-0.517	0.023	0.1848	88.6	97.1	75.1	86.1
117	2525	0.738	-0.497	0.024	0.1845	88.8	97.1	75.5	85.9

118	2524	0.730	-0.520	0.024	0.1837	89.1	97.1	75.4	86.3
119	2523	0.740	-0.544	0.024	0.1840	88.8	96.9	76.1	86.0
120	2524	0.736	-0.546	0.022	0.1852	89.0	96.8	74.5	85.8
121	2525	0.754	-0.528	0.024	0.1844	89.3	96.8	74.9	85.8
122	2517	0.738	-0.579	0.022	0.1847	89.0	96.7	75.2	86.2
123	2521	0.730	-0.586	0.021	0.1850	89.3	96.7	75.6	86.0
124	2521	0.732	-0.582	0.021	0.1849	89.2	96.7	75.3	86.2
125	2520	0.741	-0.584	0.019	0.1841	89.0	96.7	75.9	86.5
126	2518	0.745	-0.597	0.018	0.1854	89.5	96.6	75.7	86.6
127	2519	0.746	-0.624	0.017	0.1867	88.9	96.7	74.7	86.2
128	2523	0.749	-0.659	0.017	0.1846	89.3	96.9	75.4	86.2
129	2521	0.714	-0.641	0.015	0.1849	89.3	97.0	74.3	86.4
130	2522	0.697	-0.625	0.014	0.1845	89.5	96.9	74.9	86.6
131	2522	0.745	-0.644	0.014	0.1849	89.6	96.8	74.2	86.8
132	2524	0.688	-0.636	0.014	0.1858	89.4	96.6	74.6	86.7
133	2527	0.736	-0.663	0.014	0.1850	89.2	96.6	75.3	86.7
134	2527	0.684	-0.639	0.014	0.1856	89.6	96.6	74.6	87.0
135	2527	0.709	-0.677	0.014	0.1839	89.6	96.8	75.1	87.1
136	2526	0.677	-0.663	0.014	0.1848	89.5	96.8	74.9	86.7
137	2518	0.706	-0.668	0.014	0.1847	89.6	96.8	74.8	86.7
138	2525	0.709	-0.675	0.014	0.1845	89.5	96.8	75.2	86.9
139	2520	0.672	-0.673	0.014	0.1839	89.5	96.7	74.7	86.9
140	2527	0.683	-0.721	0.014	0.1847	89.4	96.7	75.0	87.0
141	2526	0.706	-0.688	0.015	0.1860	89.5	96.6	74.9	86.7
142	2523	0.705	-0.665	0.014	0.1857	89.7	96.6	75.3	86.8
143	2523	0.864	-0.691	0.015	0.1861	89.4	96.6	74.3	86.9
144	2529	0.730	-0.666	0.014	0.1852	89.6	96.7	74.5	87.0
145	2525	0.760	-0.675	0.013	0.1861	89.1	96.5	74.8	86.7
146	2526	0.751	-0.652	0.014	0.1863	89.2	96.7	74.2	86.4
147	2522	0.698	-0.653	0.011	0.1856	89.3	96.6	73.7	86.8
148	2529	0.712	-0.660	0.011	0.1852	89.2	96.8	73.4	87.0
149	2523	0.755	-0.667	0.010	0.1843	89.5	96.6	73.8	87.0
150	2525	0.704	-0.702	0.010	0.1850	89.3	96.8	73.8	87.2
151	2524	0.705	-0.688	0.008	0.1863	89.3	96.6	73.5	87.0
152	2526	0.715	-0.703	0.007	0.1863	89.5	96.8	73.1	86.9
153	2526	0.698	-0.711	0.008	0.1858	88.9	96.6	72.7	86.8
154	2523	0.723	-0.706	0.007	0.1863	89.0	96.6	72.4	87.0
155	2525	0.718	-0.729	0.007	0.1869	89.1	96.7	72.1	87.0
156	2530	0.707	-0.720	0.006	0.1871	88.8	96.6	71.9	86.9
157	2531	0.690	-0.688	0.004	0.1862	88.9	96.7	71.9	86.7
158	2531	0.920	-0.724	0.003	0.1876	89.0	96.6	72.0	86.9
159	2536	0.672	-0.736	0.004	0.1878	88.7	96.6	71.1	87.0
160	2535	0.721	-0.688	0.004	0.1878	88.2	96.6	72.4	87.0
161	2538	0.691	-0.679	0.005	0.1877	88.3	96.5	71.7	86.8
162	2539	0.658	-0.720	0.004	0.1893	88.2	96.5	72.0	86.7
163	2541	0.650	-0.674	0.004	0.1894	87.7	96.6	71.9	86.6
164	2543	0.655	-0.690	0.004	0.1900	87.8	96.5	71.3	86.5
165	2545	0.651	-0.687	0.004	0.1888	88.1	96.7	71.9	86.5
166	2541	0.642	-0.675	0.003	0.1897	87.8	96.5	71.3	86.5
167	2541	0.650	-0.694	0.004	0.1897	88.1	96.5	71.7	86.7
168	2544	0.645	-0.667	0.004	0.1904	87.9	96.3	70.9	86.6
169	2547	0.630	-0.657	0.004	0.1896	87.9	96.5	71.8	86.3
170	2548	0.663	-0.650	0.003	0.1901	87.7	96.5	71.1	86.3
171	2547	0.631	-0.636	0.002	0.1902	87.7	96.6	72.0	86.2
172	2548	0.642	-0.626	0.003	0.1898	88.0	96.4	70.9	86.3
173	2548	0.642	-0.683	0.003	0.1919	87.4	96.3	70.0	86.3
174	2546	0.655	-0.642	0.002	0.1926	87.7	96.3	70.3	86.1
175	2549	0.645	-0.639	0.003	0.1917	87.7	96.6	70.8	86.3
176	2548	0.671	-0.642	0.002	0.1911	87.5	96.5	71.0	86.3
177	2549	0.698	-0.655	0.001	0.1919	87.6	96.7	70.3	86.3
178	2549	0.666	-0.677	0.001	0.1906	87.8	96.7	70.3	86.5
179	2549	0.674	-0.636	0.001	0.1925	87.6	96.6	69.8	86.5
180	2549	0.682	-0.663	-0.001	0.1929	87.6	96.6	70.1	86.3
181	2546	0.657	-0.620	-0.002	0.1913	87.6	96.8	69.9	86.2
182	2549	0.681	-0.616	-0.002	0.1920	87.6	97.0	69.7	85.9
183	2548	0.710	-0.632	-0.001	0.1922	87.6	96.7	70.0	86.3
184	2544	0.684	-0.607	-0.001	0.1915	87.4	96.9	70.0	86.4

185	2531	0.696	-0.603	-0.002	0.1916	87.7	96.8	70.4	86.1
186	2517	0.704	-0.653	-0.003	0.1935	87.7	96.9	69.4	85.8
187	2505	0.716	-0.599	-0.002	0.1935	87.5	96.8	69.3	86.3
188	2505	0.699	-0.560	-0.002	0.1934	87.4	96.9	69.3	86.3
189	2502	0.700	-0.576	-0.003	0.1938	87.6	96.6	69.0	85.9
190	2494	0.707	-0.548	-0.002	0.1934	87.7	96.8	69.4	86.1
191	2474	0.708	-0.578	-0.003	0.1971	87.1	96.7	68.2	85.4
192	2469	0.710	-0.534	-0.004	0.1969	87.2	96.8	68.3	85.4
193	2462	0.709	-0.529	-0.006	0.1963	87.4	97.1	67.9	85.6
194	2454	0.697	-0.549	-0.004	0.1968	87.3	97.1	67.8	85.8
195	2446	0.693	-0.546	-0.006	0.1973	87.2	96.9	67.5	85.2
196	2434	0.700	-0.548	-0.007	0.1974	87.1	97.0	66.9	85.6
197	2423	0.699	-0.574	-0.007	0.1976	87.0	97.2	67.1	85.4
198	2416	0.683	-0.511	-0.007	0.1984	87.1	97.2	67.2	84.9
199	2405	0.683	-0.562	-0.008	0.1979	86.9	97.4	66.6	85.2
200	2398	0.711	-0.513	-0.008	0.1992	86.7	97.2	66.5	84.9
201	2388	0.701	-0.496	-0.009	0.1988	87.0	97.4	66.9	84.7
202	2377	0.727	-0.504	-0.008	0.2009	86.7	97.3	67.0	84.4
203	2374	0.733	-0.528	-0.009	0.2009	86.5	97.2	66.0	83.9
204	2368	0.715	-0.517	-0.010	0.2027	86.2	97.1	64.3	83.8
205	2356	0.741	-0.517	-0.009	0.2040	86.2	97.3	64.8	83.2
206	2340	0.750	-0.531	-0.010	0.2048	85.7	97.3	63.8	83.3
207	2339	0.761	-0.514	-0.009	0.2056	85.9	97.0	64.3	83.1
208	2325	0.768	-0.581	-0.010	0.2068	85.9	96.9	63.7	82.9
209	2312	0.798	-0.559	-0.009	0.2091	85.2	96.8	63.5	82.7
210	2301	0.772	-0.579	-0.011	0.2097	85.1	96.8	62.2	82.7
211	2295	0.751	-0.573	-0.011	0.2108	84.7	96.5	62.3	82.1
212	2292	0.740	-0.617	-0.012	0.2131	84.4	96.3	61.0	81.8
213	2263	0.739	-0.565	-0.011	0.2139	84.3	95.9	61.2	81.3
214	2261	0.733	-0.611	-0.012	0.2155	84.1	96.1	60.5	81.5
215	2254	0.739	-0.618	-0.013	0.2167	84.3	95.8	59.9	81.3
216	2230	0.732	-0.721	-0.013	0.2183	83.8	95.8	59.5	81.2
217	2227	0.735	-0.608	-0.011	0.2194	83.6	95.6	58.8	81.2
218	2221	0.719	-0.641	-0.012	0.2193	84.0	95.7	58.1	81.5
219	2195	0.709	-0.630	-0.012	0.2208	83.9	95.5	58.7	81.0
220	2183	0.737	-0.638	-0.009	0.2216	83.2	95.5	57.7	80.8
221	2167	0.735	-0.654	-0.009	0.2226	82.8	95.6	57.7	81.0
222	2157	0.744	-0.632	-0.009	0.2237	83.0	95.5	57.4	80.3
223	2126	0.718	-0.628	-0.009	0.2254	82.6	95.2	57.4	80.4
224	2117	0.715	-0.631	-0.006	0.2248	82.8	95.0	57.5	80.7
225	2105	0.767	-0.712	-0.007	0.2258	82.7	95.2	57.5	80.9
226	2076	0.745	-0.656	-0.006	0.2275	82.0	94.9	56.6	80.7
227	2069	0.761	-0.655	-0.005	0.2280	82.1	95.0	57.0	80.5
228	2022	0.783	-0.644	-0.005	0.2302	82.2	94.9	57.2	80.5
229	2012	0.829	-0.677	-0.007	0.2290	82.0	94.8	58.2	81.0
230	1995	0.816	-0.635	-0.009	0.2278	82.4	95.0	58.6	81.8
231	1962	0.830	-0.665	-0.013	0.2267	83.1	94.8	59.4	82.8
232	1942	0.869	-0.681	-0.013	0.2244	83.8	95.1	59.5	83.8
233	1897	0.895	-0.679	-0.018	0.2203	85.2	95.2	60.5	85.1
234	1859	0.918	-0.692	-0.023	0.2171	86.6	94.8	60.9	86.3
235	1815	0.948	-0.638	-0.022	0.2155	86.6	95.5	60.4	86.8
236	1787	0.975	-0.649	-0.021	0.2167	86.8	95.6	61.1	86.6
237	1744	1.015	-0.636	-0.017	0.2183	86.6	95.4	60.0	86.4
238	1710	1.003	-0.611	-0.016	0.2182	86.2	95.8	59.2	86.4
239	1677	1.065	-0.622	-0.010	0.2181	87.3	96.1	58.3	86.5
240	1595	1.073	-0.617	0.008	0.2087	89.3	96.9	60.1	87.6

Classification report 1 of 3

IHO statistics a/b are : 0.250 0.008

User#	Total	# fail	% fail	# pass	% pass
=====	=====	=====	=====	=====	=====
1	1685	456	27.06	1229	72.94
2	1727	461	26.69	1266	73.31
3	1774	457	25.76	1317	74.24
4	1802	463	25.69	1339	74.31
5	1831	452	24.69	1379	75.31
6	1864	462	24.79	1402	75.21
7	1911	469	24.54	1442	75.46
8	1929	467	24.21	1462	75.79
9	1948	485	24.90	1463	75.10
10	1978	488	24.67	1490	75.33
11	2001	477	23.84	1524	76.16
12	2011	470	23.37	1541	76.63
13	2024	464	22.92	1560	77.08
14	2054	451	21.96	1603	78.04
15	2062	439	21.29	1623	78.71
16	2080	442	21.25	1638	78.75
17	2112	441	20.88	1671	79.12
18	2118	436	20.59	1682	79.41
19	2131	442	20.74	1689	79.26
20	2183	436	19.97	1747	80.03
21	2193	445	20.29	1748	79.71
22	2204	439	19.92	1765	80.08
23	2214	443	20.01	1771	79.99
24	2242	440	19.63	1802	80.37
25	2255	437	19.38	1818	80.62
26	2260	434	19.20	1826	80.80
27	2271	434	19.11	1837	80.89
28	2295	450	19.61	1845	80.39
29	2298	441	19.19	1857	80.81
30	2305	430	18.66	1875	81.34
31	2314	442	19.10	1872	80.90
32	2332	439	18.83	1893	81.17
33	2338	423	18.09	1915	81.91
34	2348	418	17.80	1930	82.20
35	2353	421	17.89	1932	82.11
36	2357	421	17.86	1936	82.14
37	2373	410	17.28	1963	82.72
38	2379	409	17.19	1970	82.81
39	2385	411	17.23	1974	82.77
40	2389	404	16.91	1985	83.09
41	2394	385	16.08	2009	83.92
42	2411	396	16.42	2015	83.58
43	2423	392	16.18	2031	83.82
44	2426	372	15.33	2054	84.67
45	2429	380	15.64	2049	84.36
46	2439	373	15.29	2066	84.71
47	2444	370	15.14	2074	84.86
48	2457	351	14.29	2106	85.71
49	2473	347	14.03	2126	85.97
50	2475	337	13.62	2138	86.38
51	2477	335	13.52	2142	86.48
52	2484	321	12.92	2163	87.08
53	2503	322	12.86	2181	87.14
54	2506	318	12.69	2188	87.31
55	2506	308	12.29	2198	87.71
56	2513	308	12.26	2205	87.74
57	2515	301	11.97	2214	88.03
58	2525	289	11.45	2236	88.55
59	2524	293	11.61	2231	88.39
60	2521	284	11.27	2237	88.73
61	2521	290	11.50	2231	88.50

62	2518	284	11.28	2234	88.72
63	2518	285	11.32	2233	88.68
64	2517	278	11.04	2239	88.96
65	2514	279	11.10	2235	88.90
66	2514	278	11.06	2236	88.94
67	2511	279	11.11	2232	88.89
68	2510	271	10.80	2239	89.20
69	2513	273	10.86	2240	89.14
70	2516	270	10.73	2246	89.27
71	2515	271	10.78	2244	89.22
72	2516	274	10.89	2242	89.11
73	2517	277	11.01	2240	88.99
74	2517	272	10.81	2245	89.19
75	2518	270	10.72	2248	89.28
76	2520	281	11.15	2239	88.85
77	2519	272	10.80	2247	89.20
78	2522	280	11.10	2242	88.90
79	2522	278	11.02	2244	88.98
80	2521	278	11.03	2243	88.97
81	2523	292	11.57	2231	88.43
82	2524	276	10.94	2248	89.06
83	2523	279	11.06	2244	88.94
84	2521	293	11.62	2228	88.38
85	2523	295	11.69	2228	88.31
86	2525	296	11.72	2229	88.28
87	2524	294	11.65	2230	88.35
88	2523	298	11.81	2225	88.19
89	2523	309	12.25	2214	87.75
90	2524	308	12.20	2216	87.80
91	2523	303	12.01	2220	87.99
92	2528	306	12.10	2222	87.90
93	2529	307	12.14	2222	87.86
94	2528	309	12.22	2219	87.78
95	2522	304	12.05	2218	87.95
96	2529	308	12.18	2221	87.82
97	2528	311	12.30	2217	87.70
98	2530	307	12.13	2223	87.87
99	2531	308	12.17	2223	87.83
100	2535	311	12.27	2224	87.73
101	2529	313	12.38	2216	87.62
102	2533	312	12.32	2221	87.68
103	2533	314	12.40	2219	87.60
104	2534	305	12.04	2229	87.96
105	2534	305	12.04	2229	87.96
106	2532	323	12.76	2209	87.24
107	2525	303	12.00	2222	88.00
108	2531	305	12.05	2226	87.95
109	2530	319	12.61	2211	87.39
110	2530	319	12.61	2211	87.39
111	2529	318	12.57	2211	87.43
112	2523	309	12.25	2214	87.75
113	2526	320	12.67	2206	87.33
114	2527	311	12.31	2216	87.69
115	2525	308	12.20	2217	87.80
116	2527	316	12.50	2211	87.50
117	2525	317	12.55	2208	87.45
118	2524	311	12.32	2213	87.68
119	2523	313	12.41	2210	87.59
120	2524	305	12.08	2219	87.92
121	2525	306	12.12	2219	87.88
122	2517	304	12.08	2213	87.92
123	2521	308	12.22	2213	87.78
124	2521	302	11.98	2219	88.02
125	2520	299	11.87	2221	88.13
126	2518	288	11.44	2230	88.56
127	2519	296	11.75	2223	88.25
128	2523	299	11.85	2224	88.15

129	2521	291	11.54	2230	88.46
130	2522	296	11.74	2226	88.26
131	2522	293	11.62	2229	88.38
132	2524	299	11.85	2225	88.15
133	2527	292	11.56	2235	88.44
134	2527	293	11.59	2234	88.41
135	2527	289	11.44	2238	88.56
136	2526	295	11.68	2231	88.32
137	2518	293	11.64	2225	88.36
138	2525	304	12.04	2221	87.96
139	2520	291	11.55	2229	88.45
140	2527	296	11.71	2231	88.29
141	2526	295	11.68	2231	88.32
142	2523	296	11.73	2227	88.27
143	2523	294	11.65	2229	88.35
144	2529	292	11.55	2237	88.45
145	2525	305	12.08	2220	87.92
146	2526	289	11.44	2237	88.56
147	2522	297	11.78	2225	88.22
148	2529	300	11.86	2229	88.14
149	2523	292	11.57	2231	88.43
150	2525	291	11.52	2234	88.48
151	2524	297	11.77	2227	88.23
152	2526	291	11.52	2235	88.48
153	2526	303	12.00	2223	88.00
154	2523	301	11.93	2222	88.07
155	2525	290	11.49	2235	88.51
156	2530	312	12.33	2218	87.67
157	2531	295	11.66	2236	88.34
158	2531	310	12.25	2221	87.75
159	2536	313	12.34	2223	87.66
160	2535	313	12.35	2222	87.65
161	2538	320	12.61	2218	87.39
162	2539	327	12.88	2212	87.12
163	2541	323	12.71	2218	87.29
164	2543	326	12.82	2217	87.18
165	2545	321	12.61	2224	87.39
166	2541	329	12.95	2212	87.05
167	2541	315	12.40	2226	87.60
168	2544	335	13.17	2209	86.83
169	2547	325	12.76	2222	87.24
170	2548	331	12.99	2217	87.01
171	2547	332	13.03	2215	86.97
172	2548	323	12.68	2225	87.32
173	2548	340	13.34	2208	86.66
174	2546	338	13.28	2208	86.72
175	2549	330	12.95	2219	87.05
176	2548	336	13.19	2212	86.81
177	2549	337	13.22	2212	86.78
178	2549	333	13.06	2216	86.94
179	2549	345	13.53	2204	86.47
180	2549	338	13.26	2211	86.74
181	2546	336	13.20	2210	86.80
182	2549	339	13.30	2210	86.70
183	2548	341	13.38	2207	86.62
184	2544	345	13.56	2199	86.44
185	2531	343	13.55	2188	86.45
186	2517	344	13.67	2173	86.33
187	2505	341	13.61	2164	86.39
188	2505	341	13.61	2164	86.39
189	2502	339	13.55	2163	86.45
190	2494	334	13.39	2160	86.61
191	2474	339	13.70	2135	86.30
192	2469	343	13.89	2126	86.11
193	2462	336	13.65	2126	86.35
194	2454	343	13.98	2111	86.02
195	2446	342	13.98	2104	86.02

196	2434	341	14.01	2093	85.99
197	2423	338	13.95	2085	86.05
198	2416	330	13.66	2086	86.34
199	2405	329	13.68	2076	86.32
200	2398	340	14.18	2058	85.82
201	2388	328	13.74	2060	86.26
202	2377	335	14.09	2042	85.91
203	2374	348	14.66	2026	85.34
204	2368	359	15.16	2009	84.84
205	2356	360	15.28	1996	84.72
206	2340	360	15.38	1980	84.62
207	2339	360	15.39	1979	84.61
208	2325	372	16.00	1953	84.00
209	2312	373	16.13	1939	83.87
210	2301	381	16.56	1920	83.44
211	2295	379	16.51	1916	83.49
212	2292	395	17.23	1897	82.77
213	2263	385	17.01	1878	82.99
214	2261	388	17.16	1873	82.84
215	2254	396	17.57	1858	82.43
216	2230	395	17.71	1835	82.29
217	2227	394	17.69	1833	82.31
218	2221	387	17.42	1834	82.58
219	2195	394	17.95	1801	82.05
220	2183	399	18.28	1784	81.72
221	2167	401	18.50	1766	81.50
222	2157	391	18.13	1766	81.87
223	2126	398	18.72	1728	81.28
224	2117	390	18.42	1727	81.58
225	2105	397	18.86	1708	81.14
226	2076	395	19.03	1681	80.97
227	2069	396	19.14	1673	80.86
228	2022	389	19.24	1633	80.76
229	2012	385	19.14	1627	80.86
230	1995	374	18.75	1621	81.25
231	1962	348	17.74	1614	82.26
232	1942	329	16.94	1613	83.06
233	1897	293	15.45	1604	84.55
234	1859	260	13.99	1599	86.01
235	1815	258	14.21	1557	85.79
236	1787	249	13.93	1538	86.07
237	1744	240	13.76	1504	86.24
238	1710	231	13.51	1479	86.49
239	1677	219	13.06	1458	86.94
240	1595	185	11.60	1410	88.40

Classification report 2 of 3

IHO statistics a/b are : 0.500 0.013

User#	Total	# fail	% fail	# pass	% pass
=====	=====	=====	=====	=====	=====
1	1685	59	3.50	1626	96.50
2	1727	58	3.36	1669	96.64
3	1774	53	2.99	1721	97.01
4	1802	54	3.00	1748	97.00
5	1831	58	3.17	1773	96.83
6	1864	73	3.92	1791	96.08
7	1911	86	4.50	1825	95.50
8	1929	84	4.35	1845	95.65
9	1948	82	4.21	1866	95.79
10	1978	81	4.10	1897	95.90
11	2001	80	4.00	1921	96.00
12	2011	82	4.08	1929	95.92
13	2024	82	4.05	1942	95.95
14	2054	77	3.75	1977	96.25
15	2062	80	3.88	1982	96.12
16	2080	79	3.80	2001	96.20
17	2112	73	3.46	2039	96.54
18	2118	74	3.49	2044	96.51
19	2131	70	3.28	2061	96.72
20	2183	73	3.34	2110	96.66
21	2193	73	3.33	2120	96.67
22	2204	71	3.22	2133	96.78
23	2214	76	3.43	2138	96.57
24	2242	75	3.35	2167	96.65
25	2255	71	3.15	2184	96.85
26	2260	68	3.01	2192	96.99
27	2271	67	2.95	2204	97.05
28	2295	70	3.05	2225	96.95
29	2298	67	2.92	2231	97.08
30	2305	66	2.86	2239	97.14
31	2314	64	2.77	2250	97.23
32	2332	60	2.57	2272	97.43
33	2338	61	2.61	2277	97.39
34	2348	61	2.60	2287	97.40
35	2353	60	2.55	2293	97.45
36	2357	63	2.67	2294	97.33
37	2373	60	2.53	2313	97.47
38	2379	52	2.19	2327	97.81
39	2385	53	2.22	2332	97.78
40	2389	54	2.26	2335	97.74
41	2394	50	2.09	2344	97.91
42	2411	48	1.99	2363	98.01
43	2423	42	1.73	2381	98.27
44	2426	40	1.65	2386	98.35
45	2429	32	1.32	2397	98.68
46	2439	42	1.72	2397	98.28
47	2444	33	1.35	2411	98.65
48	2457	31	1.26	2426	98.74
49	2473	34	1.37	2439	98.63
50	2475	30	1.21	2445	98.79
51	2477	32	1.29	2445	98.71
52	2484	34	1.37	2450	98.63
53	2503	29	1.16	2474	98.84
54	2506	28	1.12	2478	98.88
55	2506	34	1.36	2472	98.64
56	2513	27	1.07	2486	98.93
57	2515	32	1.27	2483	98.73
58	2525	35	1.39	2490	98.61
59	2524	31	1.23	2493	98.77
60	2521	35	1.39	2486	98.61
61	2521	33	1.31	2488	98.69

62	2518	36	1.43	2482	98.57
63	2518	31	1.23	2487	98.77
64	2517	30	1.19	2487	98.81
65	2514	29	1.15	2485	98.85
66	2514	28	1.11	2486	98.89
67	2511	29	1.15	2482	98.85
68	2510	31	1.24	2479	98.76
69	2513	28	1.11	2485	98.89
70	2516	34	1.35	2482	98.65
71	2515	38	1.51	2477	98.49
72	2516	35	1.39	2481	98.61
73	2517	35	1.39	2482	98.61
74	2517	37	1.47	2480	98.53
75	2518	39	1.55	2479	98.45
76	2520	41	1.63	2479	98.37
77	2519	43	1.71	2476	98.29
78	2522	44	1.74	2478	98.26
79	2522	44	1.74	2478	98.26
80	2521	44	1.75	2477	98.25
81	2523	42	1.66	2481	98.34
82	2524	47	1.86	2477	98.14
83	2523	43	1.70	2480	98.30
84	2521	45	1.79	2476	98.21
85	2523	48	1.90	2475	98.10
86	2525	47	1.86	2478	98.14
87	2524	49	1.94	2475	98.06
88	2523	52	2.06	2471	97.94
89	2523	50	1.98	2473	98.02
90	2524	53	2.10	2471	97.90
91	2523	57	2.26	2466	97.74
92	2528	53	2.10	2475	97.90
93	2529	56	2.21	2473	97.79
94	2528	56	2.22	2472	97.78
95	2522	54	2.14	2468	97.86
96	2529	59	2.33	2470	97.67
97	2528	60	2.37	2468	97.63
98	2530	60	2.37	2470	97.63
99	2531	58	2.29	2473	97.71
100	2535	60	2.37	2475	97.63
101	2529	60	2.37	2469	97.63
102	2533	58	2.29	2475	97.71
103	2533	62	2.45	2471	97.55
104	2534	63	2.49	2471	97.51
105	2534	60	2.37	2474	97.63
106	2532	60	2.37	2472	97.63
107	2525	59	2.34	2466	97.66
108	2531	59	2.33	2472	97.67
109	2530	56	2.21	2474	97.79
110	2530	56	2.21	2474	97.79
111	2529	62	2.45	2467	97.55
112	2523	58	2.30	2465	97.70
113	2526	59	2.34	2467	97.66
114	2527	59	2.33	2468	97.67
115	2525	60	2.38	2465	97.62
116	2527	60	2.37	2467	97.63
117	2525	58	2.30	2467	97.70
118	2524	60	2.38	2464	97.62
119	2523	54	2.14	2469	97.86
120	2524	56	2.22	2468	97.78
121	2525	55	2.18	2470	97.82
122	2517	58	2.30	2459	97.70
123	2521	57	2.26	2464	97.74
124	2521	61	2.42	2460	97.58
125	2520	59	2.34	2461	97.66
126	2518	62	2.46	2456	97.54
127	2519	61	2.42	2458	97.58
128	2523	59	2.34	2464	97.66

129	2521	58	2.30	2463	97.70
130	2522	59	2.34	2463	97.66
131	2522	60	2.38	2462	97.62
132	2524	60	2.38	2464	97.62
133	2527	60	2.37	2467	97.63
134	2527	62	2.45	2465	97.55
135	2527	61	2.41	2466	97.59
136	2526	61	2.41	2465	97.59
137	2518	57	2.26	2461	97.74
138	2525	59	2.34	2466	97.66
139	2520	63	2.50	2457	97.50
140	2527	62	2.45	2465	97.55
141	2526	66	2.61	2460	97.39
142	2523	67	2.66	2456	97.34
143	2523	64	2.54	2459	97.46
144	2529	64	2.53	2465	97.47
145	2525	63	2.50	2462	97.50
146	2526	65	2.57	2461	97.43
147	2522	61	2.42	2461	97.58
148	2529	54	2.14	2475	97.86
149	2523	59	2.34	2464	97.66
150	2525	61	2.42	2464	97.58
151	2524	61	2.42	2463	97.58
152	2526	54	2.14	2472	97.86
153	2526	56	2.22	2470	97.78
154	2523	63	2.50	2460	97.50
155	2525	60	2.38	2465	97.62
156	2530	61	2.41	2469	97.59
157	2531	57	2.25	2474	97.75
158	2531	61	2.41	2470	97.59
159	2536	61	2.41	2475	97.59
160	2535	60	2.37	2475	97.63
161	2538	57	2.25	2481	97.75
162	2539	54	2.13	2485	97.87
163	2541	59	2.32	2482	97.68
164	2543	60	2.36	2483	97.64
165	2545	58	2.28	2487	97.72
166	2541	58	2.28	2483	97.72
167	2541	58	2.28	2483	97.72
168	2544	59	2.32	2485	97.68
169	2547	51	2.00	2496	98.00
170	2548	52	2.04	2496	97.96
171	2547	51	2.00	2496	98.00
172	2548	53	2.08	2495	97.92
173	2548	56	2.20	2492	97.80
174	2546	54	2.12	2492	97.88
175	2549	56	2.20	2493	97.80
176	2548	57	2.24	2491	97.76
177	2549	59	2.31	2490	97.69
178	2549	55	2.16	2494	97.84
179	2549	55	2.16	2494	97.84
180	2549	60	2.35	2489	97.65
181	2546	54	2.12	2492	97.88
182	2549	57	2.24	2492	97.76
183	2548	57	2.24	2491	97.76
184	2544	54	2.12	2490	97.88
185	2531	56	2.21	2475	97.79
186	2517	58	2.30	2459	97.70
187	2505	61	2.44	2444	97.56
188	2505	55	2.20	2450	97.80
189	2502	58	2.32	2444	97.68
190	2494	59	2.37	2435	97.63
191	2474	64	2.59	2410	97.41
192	2469	60	2.43	2409	97.57
193	2462	59	2.40	2403	97.60
194	2454	61	2.49	2393	97.51
195	2446	61	2.49	2385	97.51

196	2434	55	2.26	2379	97.74
197	2423	54	2.23	2369	97.77
198	2416	55	2.28	2361	97.72
199	2405	52	2.16	2353	97.84
200	2398	55	2.29	2343	97.71
201	2388	55	2.30	2333	97.70
202	2377	52	2.19	2325	97.81
203	2374	51	2.15	2323	97.85
204	2368	57	2.41	2311	97.59
205	2356	55	2.33	2301	97.67
206	2340	54	2.31	2286	97.69
207	2339	52	2.22	2287	97.78
208	2325	52	2.24	2273	97.76
209	2312	57	2.47	2255	97.53
210	2301	53	2.30	2248	97.70
211	2295	54	2.35	2241	97.65
212	2292	56	2.44	2236	97.56
213	2263	53	2.34	2210	97.66
214	2261	54	2.39	2207	97.61
215	2254	57	2.53	2197	97.47
216	2230	52	2.33	2178	97.67
217	2227	55	2.47	2172	97.53
218	2221	54	2.43	2167	97.57
219	2195	57	2.60	2138	97.40
220	2183	53	2.43	2130	97.57
221	2167	53	2.45	2114	97.55
222	2157	55	2.55	2102	97.45
223	2126	59	2.78	2067	97.22
224	2117	58	2.74	2059	97.26
225	2105	51	2.42	2054	97.58
226	2076	54	2.60	2022	97.40
227	2069	57	2.75	2012	97.25
228	2022	57	2.82	1965	97.18
229	2012	55	2.73	1957	97.27
230	1995	50	2.51	1945	97.49
231	1962	53	2.70	1909	97.30
232	1942	45	2.32	1897	97.68
233	1897	45	2.37	1852	97.63
234	1859	45	2.42	1814	97.58
235	1815	36	1.98	1779	98.02
236	1787	37	2.07	1750	97.93
237	1744	34	1.95	1710	98.05
238	1710	30	1.75	1680	98.25
239	1677	34	2.03	1643	97.97
240	1595	33	2.07	1562	97.93

Classification report 3 of 3

IHO statistics a/b are : 1.000 0.023

User#	Total	# fail	% fail	# pass	% pass
=====	=====	=====	=====	=====	=====
1	1685	0	0.00	1685	100.00
2	1727	0	0.00	1727	100.00
3	1774	0	0.00	1774	100.00
4	1802	0	0.00	1802	100.00
5	1831	0	0.00	1831	100.00
6	1864	0	0.00	1864	100.00
7	1911	0	0.00	1911	100.00
8	1929	0	0.00	1929	100.00
9	1948	0	0.00	1948	100.00
10	1978	0	0.00	1978	100.00
11	2001	0	0.00	2001	100.00
12	2011	0	0.00	2011	100.00
13	2024	0	0.00	2024	100.00
14	2054	0	0.00	2054	100.00
15	2062	0	0.00	2062	100.00
16	2080	0	0.00	2080	100.00
17	2112	0	0.00	2112	100.00
18	2118	0	0.00	2118	100.00
19	2131	0	0.00	2131	100.00
20	2183	0	0.00	2183	100.00
21	2193	0	0.00	2193	100.00
22	2204	0	0.00	2204	100.00
23	2214	0	0.00	2214	100.00
24	2242	0	0.00	2242	100.00
25	2255	0	0.00	2255	100.00
26	2260	0	0.00	2260	100.00
27	2271	0	0.00	2271	100.00
28	2295	0	0.00	2295	100.00
29	2298	0	0.00	2298	100.00
30	2305	0	0.00	2305	100.00
31	2314	0	0.00	2314	100.00
32	2332	0	0.00	2332	100.00
33	2338	0	0.00	2338	100.00
34	2348	0	0.00	2348	100.00
35	2353	0	0.00	2353	100.00
36	2357	0	0.00	2357	100.00
37	2373	0	0.00	2373	100.00
38	2379	0	0.00	2379	100.00
39	2385	0	0.00	2385	100.00
40	2389	0	0.00	2389	100.00
41	2394	0	0.00	2394	100.00
42	2411	0	0.00	2411	100.00
43	2423	0	0.00	2423	100.00
44	2426	0	0.00	2426	100.00
45	2429	0	0.00	2429	100.00
46	2439	0	0.00	2439	100.00
47	2444	0	0.00	2444	100.00
48	2457	0	0.00	2457	100.00
49	2473	0	0.00	2473	100.00
50	2475	0	0.00	2475	100.00
51	2477	0	0.00	2477	100.00
52	2484	0	0.00	2484	100.00
53	2503	0	0.00	2503	100.00
54	2506	0	0.00	2506	100.00
55	2506	0	0.00	2506	100.00
56	2513	0	0.00	2513	100.00
57	2515	0	0.00	2515	100.00
58	2525	0	0.00	2525	100.00
59	2524	0	0.00	2524	100.00
60	2521	0	0.00	2521	100.00
61	2521	0	0.00	2521	100.00

62	2518	0	0.00	2518	100.00
63	2518	0	0.00	2518	100.00
64	2517	0	0.00	2517	100.00
65	2514	0	0.00	2514	100.00
66	2514	0	0.00	2514	100.00
67	2511	0	0.00	2511	100.00
68	2510	0	0.00	2510	100.00
69	2513	0	0.00	2513	100.00
70	2516	0	0.00	2516	100.00
71	2515	0	0.00	2515	100.00
72	2516	0	0.00	2516	100.00
73	2517	0	0.00	2517	100.00
74	2517	0	0.00	2517	100.00
75	2518	0	0.00	2518	100.00
76	2520	0	0.00	2520	100.00
77	2519	0	0.00	2519	100.00
78	2522	0	0.00	2522	100.00
79	2522	0	0.00	2522	100.00
80	2521	0	0.00	2521	100.00
81	2523	0	0.00	2523	100.00
82	2524	0	0.00	2524	100.00
83	2523	0	0.00	2523	100.00
84	2521	0	0.00	2521	100.00
85	2523	0	0.00	2523	100.00
86	2525	0	0.00	2525	100.00
87	2524	0	0.00	2524	100.00
88	2523	0	0.00	2523	100.00
89	2523	0	0.00	2523	100.00
90	2524	0	0.00	2524	100.00
91	2523	0	0.00	2523	100.00
92	2528	0	0.00	2528	100.00
93	2529	0	0.00	2529	100.00
94	2528	0	0.00	2528	100.00
95	2522	0	0.00	2522	100.00
96	2529	0	0.00	2529	100.00
97	2528	0	0.00	2528	100.00
98	2530	0	0.00	2530	100.00
99	2531	0	0.00	2531	100.00
100	2535	0	0.00	2535	100.00
101	2529	0	0.00	2529	100.00
102	2533	0	0.00	2533	100.00
103	2533	0	0.00	2533	100.00
104	2534	0	0.00	2534	100.00
105	2534	0	0.00	2534	100.00
106	2532	0	0.00	2532	100.00
107	2525	0	0.00	2525	100.00
108	2531	0	0.00	2531	100.00
109	2530	0	0.00	2530	100.00
110	2530	0	0.00	2530	100.00
111	2529	0	0.00	2529	100.00
112	2523	0	0.00	2523	100.00
113	2526	0	0.00	2526	100.00
114	2527	0	0.00	2527	100.00
115	2525	0	0.00	2525	100.00
116	2527	0	0.00	2527	100.00
117	2525	0	0.00	2525	100.00
118	2524	0	0.00	2524	100.00
119	2523	0	0.00	2523	100.00
120	2524	0	0.00	2524	100.00
121	2525	0	0.00	2525	100.00
122	2517	0	0.00	2517	100.00
123	2521	0	0.00	2521	100.00
124	2521	0	0.00	2521	100.00
125	2520	0	0.00	2520	100.00
126	2518	0	0.00	2518	100.00
127	2519	0	0.00	2519	100.00
128	2523	0	0.00	2523	100.00

129	2521	0	0.00	2521	100.00
130	2522	0	0.00	2522	100.00
131	2522	0	0.00	2522	100.00
132	2524	0	0.00	2524	100.00
133	2527	0	0.00	2527	100.00
134	2527	0	0.00	2527	100.00
135	2527	0	0.00	2527	100.00
136	2526	0	0.00	2526	100.00
137	2518	0	0.00	2518	100.00
138	2525	0	0.00	2525	100.00
139	2520	0	0.00	2520	100.00
140	2527	0	0.00	2527	100.00
141	2526	0	0.00	2526	100.00
142	2523	0	0.00	2523	100.00
143	2523	0	0.00	2523	100.00
144	2529	0	0.00	2529	100.00
145	2525	0	0.00	2525	100.00
146	2526	0	0.00	2526	100.00
147	2522	0	0.00	2522	100.00
148	2529	0	0.00	2529	100.00
149	2523	0	0.00	2523	100.00
150	2525	0	0.00	2525	100.00
151	2524	0	0.00	2524	100.00
152	2526	0	0.00	2526	100.00
153	2526	0	0.00	2526	100.00
154	2523	0	0.00	2523	100.00
155	2525	0	0.00	2525	100.00
156	2530	0	0.00	2530	100.00
157	2531	0	0.00	2531	100.00
158	2531	0	0.00	2531	100.00
159	2536	0	0.00	2536	100.00
160	2535	0	0.00	2535	100.00
161	2538	0	0.00	2538	100.00
162	2539	0	0.00	2539	100.00
163	2541	0	0.00	2541	100.00
164	2543	0	0.00	2543	100.00
165	2545	0	0.00	2545	100.00
166	2541	0	0.00	2541	100.00
167	2541	0	0.00	2541	100.00
168	2544	0	0.00	2544	100.00
169	2547	0	0.00	2547	100.00
170	2548	0	0.00	2548	100.00
171	2547	0	0.00	2547	100.00
172	2548	0	0.00	2548	100.00
173	2548	0	0.00	2548	100.00
174	2546	0	0.00	2546	100.00
175	2549	0	0.00	2549	100.00
176	2548	0	0.00	2548	100.00
177	2549	0	0.00	2549	100.00
178	2549	0	0.00	2549	100.00
179	2549	0	0.00	2549	100.00
180	2549	0	0.00	2549	100.00
181	2546	0	0.00	2546	100.00
182	2549	0	0.00	2549	100.00
183	2548	0	0.00	2548	100.00
184	2544	0	0.00	2544	100.00
185	2531	0	0.00	2531	100.00
186	2517	0	0.00	2517	100.00
187	2505	0	0.00	2505	100.00
188	2505	0	0.00	2505	100.00
189	2502	0	0.00	2502	100.00
190	2494	0	0.00	2494	100.00
191	2474	0	0.00	2474	100.00
192	2469	0	0.00	2469	100.00
193	2462	0	0.00	2462	100.00
194	2454	0	0.00	2454	100.00
195	2446	0	0.00	2446	100.00

196	2434	0	0.00	2434	100.00
197	2423	0	0.00	2423	100.00
198	2416	0	0.00	2416	100.00
199	2405	0	0.00	2405	100.00
200	2398	0	0.00	2398	100.00
201	2388	0	0.00	2388	100.00
202	2377	0	0.00	2377	100.00
203	2374	0	0.00	2374	100.00
204	2368	0	0.00	2368	100.00
205	2356	0	0.00	2356	100.00
206	2340	0	0.00	2340	100.00
207	2339	0	0.00	2339	100.00
208	2325	0	0.00	2325	100.00
209	2312	0	0.00	2312	100.00
210	2301	0	0.00	2301	100.00
211	2295	0	0.00	2295	100.00
212	2292	0	0.00	2292	100.00
213	2263	0	0.00	2263	100.00
214	2261	0	0.00	2261	100.00
215	2254	0	0.00	2254	100.00
216	2230	0	0.00	2230	100.00
217	2227	0	0.00	2227	100.00
218	2221	0	0.00	2221	100.00
219	2195	0	0.00	2195	100.00
220	2183	0	0.00	2183	100.00
221	2167	0	0.00	2167	100.00
222	2157	0	0.00	2157	100.00
223	2126	0	0.00	2126	100.00
224	2117	0	0.00	2117	100.00
225	2105	0	0.00	2105	100.00
226	2076	0	0.00	2076	100.00
227	2069	0	0.00	2069	100.00
228	2022	0	0.00	2022	100.00
229	2012	0	0.00	2012	100.00
230	1995	0	0.00	1995	100.00
231	1962	0	0.00	1962	100.00
232	1942	0	0.00	1942	100.00
233	1897	0	0.00	1897	100.00
234	1859	0	0.00	1859	100.00
235	1815	0	0.00	1815	100.00
236	1787	0	0.00	1787	100.00
237	1744	0	0.00	1744	100.00
238	1710	0	0.00	1710	100.00
239	1677	0	0.00	1677	100.00
240	1595	0	0.00	1595	100.00

1006_Reson8101

Quality Control Report for file : C:\Temp\2004Patch\1006\1006_checkline

Elevation Range is : -37.666(m) -8.057(m)

Total number of 3D points used: 500141

Starting Time: 17-MAR-2004 22:03:38.88

Ending Time: 17-MAR-2004 22:19:00.45

Minimum tidal reduction: 0 (mm)

Maximum tidal reduction: 0 (mm)

User#	Total	Max(+)	Max(-)	Mean	Std.	3dm(%)	5dm(%)	1%(%)	1.6%(%)
=====	=====	=====	=====	=====	=====	=====	=====	=====	=====
1	3572	1.828	-1.649	-0.066	0.2629	80.8	93.0	49.8	75.1
2	4243	1.152	-1.402	-0.036	0.2333	85.6	94.2	65.3	83.1
3	4521	1.135	-1.522	-0.014	0.2409	85.6	94.0	70.9	84.7
4	4651	1.024	-1.567	-0.001	0.2265	87.0	94.6	74.2	86.3
5	4731	0.970	-1.330	0.012	0.1988	88.8	96.2	75.6	87.8
6	4875	0.992	-1.053	0.023	0.1896	89.4	96.3	76.2	88.1
7	4977	1.069	-1.956	0.037	0.1956	89.5	96.0	75.4	87.4
8	5044	1.138	-0.956	0.045	0.1929	90.1	96.1	76.1	88.0
9	5036	1.183	-0.956	0.049	0.1888	90.7	96.4	76.3	88.1
10	5033	1.238	-1.477	0.057	0.1891	91.3	96.5	76.1	88.2
11	5037	1.260	-0.970	0.067	0.1847	91.7	96.5	75.8	87.9
12	5042	1.253	-1.735	0.075	0.1859	91.6	96.3	73.6	87.3
13	5044	1.256	-0.654	0.084	0.1812	91.7	96.4	72.1	86.9
14	5049	1.269	-0.608	0.087	0.1815	91.8	96.3	71.7	86.1
15	5053	1.275	-0.652	0.093	0.1809	91.8	96.2	71.3	85.6
16	5057	1.292	-0.676	0.097	0.1812	91.5	96.2	70.5	85.4
17	5061	1.302	-0.518	0.101	0.1809	91.3	96.3	69.1	85.1
18	5056	1.302	-0.447	0.101	0.1779	91.2	96.5	69.0	85.1
19	5047	1.294	-0.496	0.100	0.1746	91.1	96.6	69.1	85.1
20	5039	1.263	-0.471	0.098	0.1712	91.2	96.8	69.2	85.6
21	5033	1.252	-0.482	0.096	0.1702	91.1	96.9	69.1	85.9
22	5034	1.290	-0.543	0.099	0.1724	90.9	96.9	68.4	85.3
23	5034	1.313	-0.515	0.099	0.1753	90.8	96.7	68.6	84.9
24	5033	1.337	-0.554	0.097	0.1778	91.0	96.6	68.7	85.0
25	5034	1.339	-0.582	0.095	0.1799	90.8	96.7	68.5	85.1
26	5036	1.383	-0.520	0.095	0.1817	90.6	96.6	68.5	85.1
27	5038	1.366	-0.511	0.098	0.1831	90.3	96.6	67.5	84.7
28	5041	1.375	-0.517	0.097	0.1847	90.3	96.7	67.7	84.6
29	5043	1.388	-0.539	0.098	0.1853	89.9	96.5	67.3	84.3
30	5045	1.392	-0.576	0.098	0.1852	89.7	96.4	67.3	84.1
31	5045	1.375	-0.598	0.098	0.1855	89.5	96.2	67.8	83.4
32	5042	1.383	-0.602	0.100	0.1865	89.4	96.2	67.1	83.6
33	5043	1.378	-0.638	0.101	0.1861	89.3	96.3	67.6	83.0
34	5047	1.382	-0.585	0.102	0.1856	89.5	96.4	67.3	83.0
35	5051	1.401	-0.630	0.101	0.1861	89.5	96.4	67.2	82.7
36	5052	1.388	-0.610	0.100	0.1855	89.6	96.2	67.8	82.9
37	5054	1.367	-0.621	0.101	0.1856	89.9	96.2	67.5	82.4
38	5053	1.375	-0.671	0.101	0.1836	89.9	96.2	67.2	82.6
39	5053	1.332	-0.699	0.100	0.1832	89.8	96.3	67.1	82.7
40	5052	1.307	-0.570	0.101	0.1813	89.9	96.3	67.0	82.4
41	5050	1.300	-0.581	0.100	0.1809	89.4	96.1	66.7	82.0
42	5050	1.273	-0.581	0.100	0.1791	89.7	96.2	67.2	82.5
43	5049	1.275	-0.652	0.100	0.1787	89.4	96.1	66.8	82.3
44	5048	1.237	-0.642	0.099	0.1784	89.2	96.2	67.0	82.1
45	5048	1.228	-0.645	0.098	0.1786	89.3	96.1	66.6	82.0
46	5041	1.191	-0.647	0.098	0.1778	89.4	96.1	67.2	82.2
47	5012	1.171	-0.681	0.098	0.1782	89.2	95.9	66.5	82.2
48	4978	1.180	-0.720	0.099	0.1784	89.1	95.9	66.5	81.7
49	4986	1.180	-0.732	0.101	0.1804	88.9	95.7	66.1	81.3
50	5006	1.188	-0.709	0.102	0.1804	88.9	95.6	66.2	81.1

51	5040	1.186	-0.767	0.102	0.1824	88.8	95.5	65.9	81.3
52	5051	1.191	-0.795	0.102	0.1830	88.6	95.3	66.3	81.3
53	5054	1.199	-0.817	0.101	0.1838	88.7	95.5	66.3	81.5
54	5055	1.182	-0.860	0.100	0.1840	88.8	95.5	66.4	81.5
55	5056	1.176	-0.831	0.100	0.1849	88.9	95.4	66.3	81.4
56	5057	1.214	-0.862	0.100	0.1856	88.7	95.4	66.4	81.7
57	5058	1.231	-0.897	0.101	0.1859	88.6	95.4	66.6	81.1
58	5059	1.221	-0.901	0.100	0.1860	88.7	95.6	66.3	81.3
59	5059	1.248	-0.834	0.101	0.1858	89.1	95.5	66.3	81.4
60	5061	1.244	-0.857	0.101	0.1842	89.1	95.5	66.5	81.7
61	5062	1.229	-0.852	0.102	0.1845	89.1	95.6	66.3	81.6
62	5062	1.228	-0.824	0.102	0.1840	89.3	95.7	65.7	81.4
63	5061	1.239	-0.861	0.103	0.1838	89.0	95.6	66.6	81.4
64	5060	1.246	-0.814	0.104	0.1832	89.2	95.7	65.9	82.2
65	5063	1.260	-0.780	0.104	0.1821	89.5	95.7	66.2	81.7
66	5062	1.252	-0.807	0.104	0.1816	89.5	96.0	66.0	82.4
67	5060	1.258	-0.807	0.103	0.1807	89.5	96.0	66.0	82.1
68	5057	1.268	-0.727	0.102	0.1775	90.4	96.1	65.9	82.7
69	5051	1.225	-0.694	0.101	0.1726	90.5	96.3	66.2	83.5
70	5046	1.218	-0.693	0.100	0.1695	90.8	96.6	66.5	83.6
71	5043	1.174	-0.634	0.097	0.1664	91.1	96.6	67.0	84.2
72	5041	1.140	-0.566	0.095	0.1646	91.7	96.7	67.0	84.8
73	5039	1.141	-0.546	0.097	0.1628	91.8	96.8	66.6	84.8
74	5038	1.097	-0.561	0.095	0.1607	91.9	96.8	66.8	85.5
75	5037	1.029	-0.526	0.097	0.1571	92.0	97.0	66.6	85.8
76	5035	0.980	-0.487	0.094	0.1552	92.2	97.0	68.5	86.3
77	5036	0.929	-0.517	0.092	0.1545	92.4	97.0	69.2	86.7
78	5039	0.984	-0.565	0.092	0.1562	92.4	96.8	69.5	86.7
79	5043	1.022	-0.568	0.090	0.1584	92.5	96.7	69.9	86.7
80	5045	1.030	-0.577	0.089	0.1599	92.4	96.7	70.2	86.7
81	5048	1.054	-0.626	0.086	0.1635	92.3	96.6	70.7	86.9
82	5053	1.101	-0.651	0.083	0.1669	92.2	96.6	70.9	87.1
83	5053	1.132	-0.650	0.086	0.1694	91.7	96.5	70.0	86.6
84	5055	1.164	-0.630	0.086	0.1717	91.5	96.5	70.1	86.4
85	5054	1.215	-0.877	0.084	0.1740	91.6	96.5	70.2	86.3
86	5050	1.222	-0.764	0.084	0.1745	91.3	96.6	70.4	86.3
87	5045	1.256	-0.610	0.081	0.1753	91.0	96.7	71.6	86.6
88	5040	1.289	-0.506	0.080	0.1772	90.6	96.8	71.8	86.7
89	5051	1.308	-0.620	0.080	0.1803	90.8	96.4	72.4	87.0
90	5054	1.304	-0.762	0.074	0.1836	90.6	96.2	73.4	86.9
91	5055	1.297	-0.577	0.070	0.1860	90.1	96.1	73.6	87.1
92	5057	1.274	-1.533	0.060	0.1912	89.8	95.9	75.5	87.3
93	5058	1.292	-0.978	0.052	0.1932	89.9	95.8	76.8	87.4
94	4961	1.280	-0.891	0.042	0.1969	90.0	95.4	77.0	87.2
95	4883	1.068	-0.949	0.025	0.1887	90.6	95.9	77.8	88.3
96	4792	1.141	-1.614	0.006	0.2101	89.6	95.1	75.6	87.9
97	4692	1.164	-1.800	-0.014	0.2331	88.7	94.5	73.4	87.0
98	4502	1.091	-2.154	-0.042	0.2519	86.8	93.7	68.8	85.9
99	4266	0.976	-1.821	-0.074	0.2644	83.2	92.2	61.5	81.1
100	3795	1.018	-1.833	-0.113	0.2902	79.8	89.9	48.7	74.1
101	2748	1.076	-1.803	-0.125	0.3052	77.0	90.2	39.3	67.2

Classification report 1 of 3

IHO statistics a/b are : 0.250 0.008

User#	Total	# fail	% fail	# pass	% pass
=====	=====	=====	=====	=====	=====
1	3572	765	21.42	2807	78.58
2	4243	654	15.41	3589	84.59
3	4521	651	14.40	3870	85.60
4	4651	598	12.86	4053	87.14
5	4731	546	11.54	4185	88.46
6	4875	531	10.89	4344	89.11
7	4977	551	11.07	4426	88.93
8	5044	529	10.49	4515	89.51
9	5036	491	9.75	4545	90.25
10	5033	464	9.22	4569	90.78
11	5037	434	8.62	4603	91.38
12	5042	448	8.89	4594	91.11
13	5044	456	9.04	4588	90.96
14	5049	465	9.21	4584	90.79
15	5053	463	9.16	4590	90.84
16	5057	489	9.67	4568	90.33
17	5061	501	9.90	4560	90.10
18	5056	503	9.95	4553	90.05
19	5047	495	9.81	4552	90.19
20	5039	488	9.68	4551	90.32
21	5033	503	9.99	4530	90.01
22	5034	520	10.33	4514	89.67
23	5034	526	10.45	4508	89.55
24	5033	509	10.11	4524	89.89
25	5034	510	10.13	4524	89.87
26	5036	519	10.31	4517	89.69
27	5038	527	10.46	4511	89.54
28	5041	540	10.71	4501	89.29
29	5043	563	11.16	4480	88.84
30	5045	591	11.71	4454	88.29
31	5045	589	11.67	4456	88.33
32	5042	595	11.80	4447	88.20
33	5043	595	11.80	4448	88.20
34	5047	601	11.91	4446	88.09
35	5051	594	11.76	4457	88.24
36	5052	586	11.60	4466	88.40
37	5054	570	11.28	4484	88.72
38	5053	573	11.34	4480	88.66
39	5053	570	11.28	4483	88.72
40	5052	567	11.22	4485	88.78
41	5050	580	11.49	4470	88.51
42	5050	586	11.60	4464	88.40
43	5049	595	11.78	4454	88.22
44	5048	593	11.75	4455	88.25
45	5048	596	11.81	4452	88.19
46	5041	589	11.68	4452	88.32
47	5012	586	11.69	4426	88.31
48	4978	589	11.83	4389	88.17
49	4986	596	11.95	4390	88.05
50	5006	597	11.93	4409	88.07
51	5040	603	11.96	4437	88.04
52	5051	615	12.18	4436	87.82
53	5054	595	11.77	4459	88.23
54	5055	609	12.05	4446	87.95
55	5056	601	11.89	4455	88.11
56	5057	595	11.77	4462	88.23
57	5058	607	12.00	4451	88.00
58	5059	598	11.82	4461	88.18
59	5059	590	11.66	4469	88.34
60	5061	587	11.60	4474	88.40
61	5062	594	11.73	4468	88.27

62	5062	585	11.56	4477	88.44
63	5061	595	11.76	4466	88.24
64	5060	591	11.68	4469	88.32
65	5063	591	11.67	4472	88.33
66	5062	587	11.60	4475	88.40
67	5060	585	11.56	4475	88.44
68	5057	555	10.97	4502	89.03
69	5051	540	10.69	4511	89.31
70	5046	523	10.36	4523	89.64
71	5043	506	10.03	4537	89.97
72	5041	482	9.56	4559	90.44
73	5039	482	9.57	4557	90.43
74	5038	452	8.97	4586	91.03
75	5037	452	8.97	4585	91.03
76	5035	430	8.54	4605	91.46
77	5036	429	8.52	4607	91.48
78	5039	427	8.47	4612	91.53
79	5043	427	8.47	4616	91.53
80	5045	425	8.42	4620	91.58
81	5048	436	8.64	4612	91.36
82	5053	443	8.77	4610	91.23
83	5053	466	9.22	4587	90.78
84	5055	470	9.30	4585	90.70
85	5054	465	9.20	4589	90.80
86	5050	473	9.37	4577	90.63
87	5045	480	9.51	4565	90.49
88	5040	488	9.68	4552	90.32
89	5051	497	9.84	4554	90.16
90	5054	510	10.09	4544	89.91
91	5055	524	10.37	4531	89.63
92	5057	541	10.70	4516	89.30
93	5058	544	10.76	4514	89.24
94	4961	522	10.52	4439	89.48
95	4883	470	9.63	4413	90.37
96	4792	509	10.62	4283	89.38
97	4692	563	12.00	4129	88.00
98	4502	615	13.66	3887	86.34
99	4266	741	17.37	3525	82.63
100	3795	832	21.92	2963	78.08
101	2748	705	25.66	2043	74.34

Classification report 2 of 3

IHO statistics a/b are : 0.500 0.013

User#	Total	# fail	% fail	# pass	% pass
=====	=====	=====	=====	=====	=====
1	3572	196	5.49	3376	94.51
2	4243	182	4.29	4061	95.71
3	4521	211	4.67	4310	95.33
4	4651	192	4.13	4459	95.87
5	4731	148	3.13	4583	96.87
6	4875	142	2.91	4733	97.09
7	4977	161	3.23	4816	96.77
8	5044	170	3.37	4874	96.63
9	5036	161	3.20	4875	96.80
10	5033	161	3.20	4872	96.80
11	5037	167	3.32	4870	96.68
12	5042	175	3.47	4867	96.53
13	5044	163	3.23	4881	96.77
14	5049	167	3.31	4882	96.69
15	5053	173	3.42	4880	96.58
16	5057	170	3.36	4887	96.64
17	5061	176	3.48	4885	96.52
18	5056	171	3.38	4885	96.62
19	5047	159	3.15	4888	96.85
20	5039	151	3.00	4888	97.00
21	5033	142	2.82	4891	97.18
22	5034	144	2.86	4890	97.14
23	5034	145	2.88	4889	97.12
24	5033	141	2.80	4892	97.20
25	5034	142	2.82	4892	97.18
26	5036	146	2.90	4890	97.10
27	5038	149	2.96	4889	97.04
28	5041	154	3.05	4887	96.95
29	5043	154	3.05	4889	96.95
30	5045	152	3.01	4893	96.99
31	5045	157	3.11	4888	96.89
32	5042	157	3.11	4885	96.89
33	5043	161	3.19	4882	96.81
34	5047	157	3.11	4890	96.89
35	5051	160	3.17	4891	96.83
36	5052	164	3.25	4888	96.75
37	5054	157	3.11	4897	96.89
38	5053	161	3.19	4892	96.81
39	5053	157	3.11	4896	96.89
40	5052	158	3.13	4894	96.87
41	5050	163	3.23	4887	96.77
42	5050	152	3.01	4898	96.99
43	5049	157	3.11	4892	96.89
44	5048	150	2.97	4898	97.03
45	5048	153	3.03	4895	96.97
46	5041	150	2.98	4891	97.02
47	5012	160	3.19	4852	96.81
48	4978	158	3.17	4820	96.83
49	4986	170	3.41	4816	96.59
50	5006	169	3.38	4837	96.62
51	5040	170	3.37	4870	96.63
52	5051	180	3.56	4871	96.44
53	5054	183	3.62	4871	96.38
54	5055	181	3.58	4874	96.42
55	5056	190	3.76	4866	96.24
56	5057	189	3.74	4868	96.26
57	5058	192	3.80	4866	96.20
58	5059	190	3.76	4869	96.24
59	5059	193	3.81	4866	96.19
60	5061	193	3.81	4868	96.19
61	5062	189	3.73	4873	96.27

62	5062	190	3.75	4872	96.25
63	5061	193	3.81	4868	96.19
64	5060	186	3.68	4874	96.32
65	5063	189	3.73	4874	96.27
66	5062	176	3.48	4886	96.52
67	5060	176	3.48	4884	96.52
68	5057	170	3.36	4887	96.64
69	5051	162	3.21	4889	96.79
70	5046	149	2.95	4897	97.05
71	5043	144	2.86	4899	97.14
72	5041	142	2.82	4899	97.18
73	5039	146	2.90	4893	97.10
74	5038	142	2.82	4896	97.18
75	5037	140	2.78	4897	97.22
76	5035	141	2.80	4894	97.20
77	5036	140	2.78	4896	97.22
78	5039	142	2.82	4897	97.18
79	5043	144	2.86	4899	97.14
80	5045	152	3.01	4893	96.99
81	5048	153	3.03	4895	96.97
82	5053	157	3.11	4896	96.89
83	5053	157	3.11	4896	96.89
84	5055	160	3.17	4895	96.83
85	5054	162	3.21	4892	96.79
86	5050	159	3.15	4891	96.85
87	5045	149	2.95	4896	97.05
88	5040	150	2.98	4890	97.02
89	5051	161	3.19	4890	96.81
90	5054	172	3.40	4882	96.60
91	5055	177	3.50	4878	96.50
92	5057	185	3.66	4872	96.34
93	5058	191	3.78	4867	96.22
94	4961	193	3.89	4768	96.11
95	4883	160	3.28	4723	96.72
96	4792	187	3.90	4605	96.10
97	4692	210	4.48	4482	95.52
98	4502	218	4.84	4284	95.16
99	4266	254	5.95	4012	94.05
100	3795	293	7.72	3502	92.28
101	2748	232	8.44	2516	91.56

Classification report 3 of 3

IHO statistics a/b are : 1.000 0.023

User#	Total	# fail	% fail	# pass	% pass
=====	=====	=====	=====	=====	=====
1	3572	6	0.17	3566	99.83
2	4243	9	0.21	4234	99.79
3	4521	19	0.42	4502	99.58
4	4651	7	0.15	4644	99.85
5	4731	2	0.04	4729	99.96
6	4875	0	0.00	4875	100.00
7	4977	10	0.20	4967	99.80
8	5044	18	0.36	5026	99.64
9	5036	24	0.48	5012	99.52
10	5033	33	0.66	5000	99.34
11	5037	33	0.66	5004	99.34
12	5042	35	0.69	5007	99.31
13	5044	34	0.67	5010	99.33
14	5049	36	0.71	5013	99.29
15	5053	35	0.69	5018	99.31
16	5057	36	0.71	5021	99.29
17	5061	35	0.69	5026	99.31
18	5056	31	0.61	5025	99.39
19	5047	27	0.53	5020	99.47
20	5039	23	0.46	5016	99.54
21	5033	20	0.40	5013	99.60
22	5034	22	0.44	5012	99.56
23	5034	24	0.48	5010	99.52
24	5033	26	0.52	5007	99.48
25	5034	26	0.52	5008	99.48
26	5036	28	0.56	5008	99.44
27	5038	29	0.58	5009	99.42
28	5041	31	0.61	5010	99.39
29	5043	33	0.65	5010	99.35
30	5045	31	0.61	5014	99.39
31	5045	28	0.56	5017	99.44
32	5042	32	0.63	5010	99.37
33	5043	30	0.59	5013	99.41
34	5047	30	0.59	5017	99.41
35	5051	29	0.57	5022	99.43
36	5052	31	0.61	5021	99.39
37	5054	29	0.57	5025	99.43
38	5053	28	0.55	5025	99.45
39	5053	27	0.53	5026	99.47
40	5052	25	0.49	5027	99.51
41	5050	22	0.44	5028	99.56
42	5050	21	0.42	5029	99.58
43	5049	18	0.36	5031	99.64
44	5048	16	0.32	5032	99.68
45	5048	14	0.28	5034	99.72
46	5041	13	0.26	5028	99.74
47	5012	10	0.20	5002	99.80
48	4978	8	0.16	4970	99.84
49	4986	10	0.20	4976	99.80
50	5006	9	0.18	4997	99.82
51	5040	11	0.22	5029	99.78
52	5051	11	0.22	5040	99.78
53	5054	12	0.24	5042	99.76
54	5055	11	0.22	5044	99.78
55	5056	12	0.24	5044	99.76
56	5057	13	0.26	5044	99.74
57	5058	14	0.28	5044	99.72
58	5059	14	0.28	5045	99.72
59	5059	15	0.30	5044	99.70
60	5061	15	0.30	5046	99.70
61	5062	17	0.34	5045	99.66

62	5062	17	0.34	5045	99.66
63	5061	19	0.38	5042	99.62
64	5060	20	0.40	5040	99.60
65	5063	22	0.43	5041	99.57
66	5062	23	0.45	5039	99.55
67	5060	21	0.42	5039	99.58
68	5057	21	0.42	5036	99.58
69	5051	16	0.32	5035	99.68
70	5046	15	0.30	5031	99.70
71	5043	13	0.26	5030	99.74
72	5041	11	0.22	5030	99.78
73	5039	9	0.18	5030	99.82
74	5038	5	0.10	5033	99.90
75	5037	1	0.02	5036	99.98
76	5035	0	0.00	5035	100.00
77	5036	0	0.00	5036	100.00
78	5039	0	0.00	5039	100.00
79	5043	0	0.00	5043	100.00
80	5045	1	0.02	5044	99.98
81	5048	3	0.06	5045	99.94
82	5053	3	0.06	5050	99.94
83	5053	5	0.10	5048	99.90
84	5055	8	0.16	5047	99.84
85	5054	9	0.18	5045	99.82
86	5050	10	0.20	5040	99.80
87	5045	13	0.26	5032	99.74
88	5040	14	0.28	5026	99.72
89	5051	17	0.34	5034	99.66
90	5054	16	0.32	5038	99.68
91	5055	16	0.32	5039	99.68
92	5057	16	0.32	5041	99.68
93	5058	14	0.28	5044	99.72
94	4961	13	0.26	4948	99.74
95	4883	3	0.06	4880	99.94
96	4792	8	0.17	4784	99.83
97	4692	23	0.49	4669	99.51
98	4502	26	0.58	4476	99.42
99	4266	16	0.38	4250	99.62
100	3795	25	0.66	3770	99.34
101	2748	25	0.91	2723	99.09

1015_Elac1180

Quality Control Report for file :
 C:\Temp\2004Patch\1015_Elac\1015_elac_checkline

Elevation Range is : -105.237(m) -49.416(m)

Total number of 3D points used: 9592

Starting Time: 26-MAR-2004 19:40:35.81
 Ending Time: 26-MAR-2004 19:42:16.87

Minimum tidal reduction: 0 (mm)
 Maximum tidal reduction: 0 (mm)

User#	Total	Max(+)	Max(-)	Mean	Std.	3dm(%)	5dm(%)	1%(%)	1.6%(%)
10	89	1.656	-2.772	-0.346	0.7184	31.5	55.1	70.8	89.9
11	89	1.143	-1.720	-0.617	0.5918	21.3	37.1	47.2	82.0
12	89	1.123	-2.384	-0.638	0.6138	25.8	34.8	53.9	85.4
13	88	1.245	-2.585	-0.532	0.6371	34.1	46.6	69.3	87.5
14	88	1.596	-2.220	-0.772	0.6620	18.2	36.4	44.3	80.7
15	87	1.122	-2.983	-0.874	0.6451	10.3	28.7	43.7	77.0
16	89	0.076	-2.560	-0.995	0.5855	9.0	25.8	34.8	64.0
17	89	0.365	-2.575	-1.090	0.6703	9.0	23.6	27.0	53.9
18	89	0.848	-2.762	-1.018	0.7540	9.0	24.7	36.0	59.6
19	89	2.713	-2.708	-0.841	0.8153	20.2	32.6	48.3	59.6
20	89	0.222	-3.249	-1.278	0.7741	7.9	14.6	25.8	46.1
21	89	0.438	-3.448	-1.231	0.8148	6.7	20.2	28.1	50.6
22	89	0.892	-3.294	-0.711	0.8674	22.5	32.6	46.1	74.2
23	89	0.516	-3.775	-1.570	0.9594	3.4	6.7	13.5	31.5
24	89	1.316	-4.953	-1.666	1.0837	2.2	6.7	12.4	29.2
25	88	1.657	-3.788	-1.015	1.0884	15.9	23.9	31.8	52.3
26	88	0.606	-5.128	-2.100	1.1716	4.5	4.5	5.7	20.5
27	88	1.041	-4.251	-1.798	0.8900	0.0	3.4	4.5	15.9
28	86	0.709	-7.333	-1.673	1.5306	7.0	11.6	19.8	45.3
29	89	2.106	-4.664	-1.718	1.1052	3.4	3.4	6.7	18.0
30	89	2.382	-3.721	-1.089	0.9625	4.5	12.4	20.2	53.9
31	89	1.218	-4.007	-1.249	0.9988	10.1	20.2	25.8	51.7
32	89	1.103	-2.623	-0.638	0.7330	24.7	30.3	42.7	79.8
33	89	2.059	-2.866	-0.492	0.8754	24.7	36.0	48.3	78.7
34	89	0.633	-2.627	-0.635	0.8300	28.1	47.2	62.9	77.5
35	89	1.070	-2.124	-0.497	0.6776	30.3	50.6	61.8	85.4
36	89	0.532	-2.618	-1.160	0.7384	4.5	11.2	18.0	44.9
37	89	0.774	-2.479	-0.601	0.6467	24.7	48.3	66.3	84.3
38	89	0.654	-2.533	-0.768	0.6864	21.3	36.0	46.1	71.9
39	89	0.632	-3.960	-1.101	0.8394	13.5	19.1	28.1	48.3
40	89	0.108	-2.786	-0.971	0.6536	11.2	23.6	36.0	70.8
41	89	0.568	-2.631	-1.000	0.6951	9.0	24.7	33.7	62.9
42	89	0.432	-2.663	-0.953	0.6597	9.0	30.3	40.4	67.4
43	89	0.108	-2.723	-0.989	0.6701	10.1	29.2	37.1	68.5
44	89	0.415	-2.613	-0.888	0.6231	16.9	27.0	38.2	74.2
45	89	0.289	-2.893	-0.863	0.6632	18.0	33.7	46.1	71.9
46	89	0.338	-3.107	-1.025	0.6743	10.1	23.6	25.8	69.7
47	89	0.794	-3.355	-1.039	0.7727	10.1	24.7	29.2	65.2
48	89	0.163	-4.616	-1.033	0.8069	10.1	24.7	33.7	64.0
49	89	0.457	-3.373	-1.099	0.8085	11.2	20.2	29.2	65.2
50	89	0.000	-3.167	-1.189	0.7875	6.7	18.0	23.6	56.2
51	89	0.096	-3.176	-1.193	0.7846	10.1	15.7	23.6	50.6
52	89	1.413	-2.944	-1.101	0.8642	6.7	16.9	25.8	56.2
53	89	2.335	-3.303	-1.083	0.9091	7.9	20.2	24.7	53.9
54	89	0.882	-3.088	-1.102	0.7918	5.6	19.1	25.8	60.7
55	89	0.616	-3.223	-0.936	0.8350	21.3	33.7	43.8	66.3
56	89	1.374	-3.150	-0.897	0.8542	21.3	38.2	48.3	71.9

57	89	0.745	-3.941	-0.882	0.9583	22.5	38.2	44.9	68.5
58	89	0.947	-3.755	-0.901	0.9693	28.1	36.0	42.7	65.2
59	89	4.048	-4.340	-0.848	1.2339	19.1	36.0	40.4	62.9
60	87	3.148	-4.270	-0.755	1.1506	18.4	29.9	40.2	64.4
61	87	3.052	-4.971	-0.512	1.2867	21.8	35.6	46.0	66.7
62	87	5.069	-4.878	-0.251	1.7722	20.7	34.5	39.1	58.6
63	87	5.706	-3.940	-0.415	1.6293	21.8	31.0	33.3	55.2
64	87	0.685	-5.524	-1.005	1.2122	18.4	29.9	37.9	67.8
65	89	0.954	-5.769	-1.202	1.2408	13.5	22.5	28.1	48.3
66	89	0.505	-6.136	-1.350	1.2356	14.6	24.7	29.2	41.6
67	89	0.877	-5.662	-1.207	1.2264	13.5	21.3	24.7	48.3
68	89	0.362	-6.274	-1.284	1.1967	11.2	21.3	22.5	49.4
69	89	0.272	-5.562	-1.378	1.1422	13.5	15.7	24.7	43.8
70	89	0.292	-5.119	-1.316	1.1389	14.6	25.8	32.6	41.6
71	89	0.187	-5.174	-1.290	1.1262	16.9	21.3	27.0	46.1
72	89	0.149	-5.039	-1.333	1.0227	10.1	15.7	23.6	42.7
73	89	0.529	-4.647	-1.139	1.0951	20.2	33.7	43.8	58.4
74	89	0.266	-4.656	-1.179	1.0181	16.9	24.7	31.5	56.2
75	89	0.284	-4.092	-1.247	0.9000	13.5	18.0	22.5	48.3
76	89	0.335	-3.692	-1.032	0.9048	20.2	31.5	40.4	62.9
77	89	0.466	-3.545	-1.069	0.8274	12.4	31.5	34.8	55.1
78	89	0.308	-3.400	-1.218	0.7918	6.7	16.9	22.5	46.1
79	89	0.465	-3.361	-0.982	0.8409	16.9	36.0	44.9	60.7
80	89	0.203	-3.404	-1.028	0.7902	13.5	29.2	40.4	58.4
81	89	0.181	-3.176	-1.064	0.7613	18.0	25.8	30.3	58.4
82	89	0.630	-2.805	-0.966	0.7053	14.6	28.1	36.0	60.7
83	89	0.058	-2.939	-1.014	0.6610	9.0	23.6	36.0	60.7
84	89	0.000	-2.570	-1.173	0.6337	5.6	14.6	21.3	48.3
85	89	0.203	-2.429	-0.922	0.6296	14.6	31.5	41.6	64.0
86	89	0.000	-2.828	-0.981	0.5856	11.2	22.5	33.7	64.0
87	89	0.015	-2.393	-1.070	0.6224	4.5	20.2	33.7	59.6
88	89	0.129	-3.274	-0.888	0.6308	14.6	31.5	42.7	69.7
89	89	0.398	-2.794	-0.926	0.6372	10.1	27.0	38.2	70.8
90	89	0.173	-2.665	-0.972	0.6272	16.9	25.8	30.3	64.0
91	89	0.094	-2.665	-0.776	0.6094	28.1	37.1	48.3	78.7
92	89	0.377	-3.063	-0.864	0.7682	25.8	38.2	47.2	66.3
93	89	0.290	-2.600	-0.921	0.6930	23.6	32.6	37.1	70.8
94	89	0.252	-3.159	-0.839	0.7541	23.6	37.1	46.1	76.4
95	89	0.866	-2.453	-0.774	0.7035	23.6	33.7	42.7	74.2
96	89	0.360	-2.671	-0.890	0.7371	22.5	27.0	39.3	66.3
97	89	0.366	-2.681	-0.716	0.7220	33.7	50.6	56.2	77.5
98	89	0.539	-2.502	-0.786	0.7139	18.0	33.7	49.4	74.2
99	89	0.544	-2.826	-0.869	0.8295	18.0	33.7	42.7	67.4
100	89	0.593	-2.784	-0.657	0.6870	20.2	39.3	57.3	82.0
101	89	0.547	-2.822	-0.731	0.7703	24.7	40.4	53.9	75.3
102	89	0.673	-2.457	-0.774	0.6998	22.5	25.8	42.7	74.2
103	89	0.909	-1.721	-0.466	0.6046	28.1	44.9	58.4	89.9
104	89	0.847	-1.812	-0.554	0.6303	27.0	41.6	58.4	82.0
105	89	0.475	-2.125	-0.612	0.6135	32.6	44.9	59.6	84.3
106	89	0.669	-1.867	-0.453	0.5496	36.0	61.8	70.8	88.8
107	89	0.441	-1.629	-0.457	0.4918	37.1	58.4	76.4	88.8
108	89	0.688	-2.164	-0.555	0.6127	28.1	41.6	55.1	86.5
109	89	0.995	-1.806	-0.497	0.5816	33.7	53.9	65.2	87.6
110	89	2.044	-1.987	-0.381	0.6640	34.8	50.6	70.8	88.8
111	89	1.824	-2.254	-0.507	0.7138	21.3	46.1	64.0	83.1
112	89	1.751	-1.978	-0.244	0.6807	33.7	51.7	68.5	88.8
113	89	2.277	-1.833	-0.273	0.6616	34.8	50.6	68.5	91.0
114	89	1.841	-1.621	-0.409	0.7038	25.8	44.9	55.1	82.0
115	89	3.202	-2.515	-0.409	0.7411	30.3	47.2	67.4	87.6
116	89	2.527	-1.534	-0.377	0.7727	19.1	33.7	49.4	82.0
117	89	2.426	-2.232	-0.490	0.7882	25.8	37.1	51.7	78.7

Classification report 1 of 3

IHO statistics a/b are : 0.250 0.008

User#	Total	# fail	% fail	# pass	% pass
=====	=====	=====	=====	=====	=====
10	89	34	38.20	55	61.80
11	89	53	59.55	36	40.45
12	89	53	59.55	36	40.45
13	88	37	42.05	51	57.95
14	88	54	61.36	34	38.64
15	87	60	68.97	27	31.03
16	89	64	71.91	25	28.09
17	89	68	76.40	21	23.60
18	89	66	74.16	23	25.84
19	89	58	65.17	31	34.83
20	89	75	84.27	14	15.73
21	89	72	80.90	17	19.10
22	89	56	62.92	33	37.08
23	89	81	91.01	8	8.99
24	89	83	93.26	6	6.74
25	88	65	73.86	23	26.14
26	88	83	94.32	5	5.68
27	88	85	96.59	3	3.41
28	86	73	84.88	13	15.12
29	89	86	96.63	3	3.37
30	89	79	88.76	10	11.24
31	89	70	78.65	19	21.35
32	89	58	65.17	31	34.83
33	89	53	59.55	36	40.45
34	89	41	46.07	48	53.93
35	89	40	44.94	49	55.06
36	89	76	85.39	13	14.61
37	89	43	48.31	46	51.69
38	89	54	60.67	35	39.33
39	89	69	77.53	20	22.47
40	89	66	74.16	23	25.84
41	89	68	76.40	21	23.60
42	89	61	68.54	28	31.46
43	89	62	69.66	27	30.34
44	89	63	70.79	26	29.21
45	89	58	65.17	31	34.83
46	89	69	77.53	20	22.47
47	89	67	75.28	22	24.72
48	89	62	69.66	27	30.34
49	89	70	78.65	19	21.35
50	89	74	83.15	15	16.85
51	89	72	80.90	17	19.10
52	89	72	80.90	17	19.10
53	89	69	77.53	20	22.47
54	89	70	78.65	19	21.35
55	89	59	66.29	30	33.71
56	89	54	60.67	35	39.33
57	89	56	62.92	33	37.08
58	89	54	60.67	35	39.33
59	89	58	65.17	31	34.83
60	87	59	67.82	28	32.18
61	87	54	62.07	33	37.93
62	87	55	63.22	32	36.78
63	87	60	68.97	27	31.03
64	87	58	66.67	29	33.33
65	89	68	76.40	21	23.60
66	89	66	74.16	23	25.84
67	89	70	78.65	19	21.35
68	89	70	78.65	19	21.35
69	89	75	84.27	14	15.73
70	89	63	70.79	26	29.21

71	89	68	76.40	21	23.60
72	89	71	79.78	18	20.22
73	89	58	65.17	31	34.83
74	89	65	73.03	24	26.97
75	89	72	80.90	17	19.10
76	89	57	64.04	32	35.96
77	89	61	68.54	28	31.46
78	89	73	82.02	16	17.98
79	89	53	59.55	36	40.45
80	89	60	67.42	29	32.58
81	89	67	75.28	22	24.72
82	89	62	69.66	27	30.34
83	89	66	74.16	23	25.84
84	89	75	84.27	14	15.73
85	89	57	64.04	32	35.96
86	89	67	75.28	22	24.72
87	89	66	74.16	23	25.84
88	89	60	67.42	29	32.58
89	89	63	70.79	26	29.21
90	89	64	71.91	25	28.09
91	89	54	60.67	35	39.33
92	89	52	58.43	37	41.57
93	89	57	64.04	32	35.96
94	89	54	60.67	35	39.33
95	89	58	65.17	31	34.83
96	89	61	68.54	28	31.46
97	89	43	48.31	46	51.69
98	89	54	60.67	35	39.33
99	89	57	64.04	32	35.96
100	89	49	55.06	40	44.94
101	89	47	52.81	42	47.19
102	89	61	68.54	28	31.46
103	89	44	49.44	45	50.56
104	89	50	56.18	39	43.82
105	89	44	49.44	45	50.56
106	89	32	35.96	57	64.04
107	89	32	35.96	57	64.04
108	89	48	53.93	41	46.07
109	89	36	40.45	53	59.55
110	89	36	40.45	53	59.55
111	89	43	48.31	46	51.69
112	89	34	38.20	55	61.80
113	89	39	43.82	50	56.18
114	89	43	48.31	46	51.69
115	89	40	44.94	49	55.06
116	89	56	62.92	33	37.08
117	89	50	56.18	39	43.82

Classification report 2 of 3

IHO statistics a/b are : 0.500 0.013

User#	Total	# fail	% fail	# pass	% pass
=====	=====	=====	=====	=====	=====
10	89	15	16.85	74	83.15
11	89	20	22.47	69	77.53
12	89	18	20.22	71	79.78
13	88	14	15.91	74	84.09
14	88	24	27.27	64	72.73
15	87	25	28.74	62	71.26
16	89	36	40.45	53	59.55
17	89	44	49.44	45	50.56
18	89	40	44.94	49	55.06
19	89	40	44.94	49	55.06
20	89	49	55.06	40	44.94
21	89	47	52.81	42	47.19
22	89	26	29.21	63	70.79
23	89	63	70.79	26	29.21
24	89	66	74.16	23	25.84
25	88	48	54.55	40	45.45
26	88	74	84.09	14	15.91
27	88	74	84.09	14	15.91
28	86	49	56.98	37	43.02
29	89	75	84.27	14	15.73
30	89	44	49.44	45	50.56
31	89	49	55.06	40	44.94
32	89	25	28.09	64	71.91
33	89	23	25.84	66	74.16
34	89	27	30.34	62	69.66
35	89	18	20.22	71	79.78
36	89	50	56.18	39	43.82
37	89	18	20.22	71	79.78
38	89	28	31.46	61	68.54
39	89	49	55.06	40	44.94
40	89	33	37.08	56	62.92
41	89	35	39.33	54	60.67
42	89	34	38.20	55	61.80
43	89	33	37.08	56	62.92
44	89	28	31.46	61	68.54
45	89	30	33.71	59	66.29
46	89	35	39.33	54	60.67
47	89	39	43.82	50	56.18
48	89	38	42.70	51	57.30
49	89	40	44.94	49	55.06
50	89	44	49.44	45	50.56
51	89	45	50.56	44	49.44
52	89	40	44.94	49	55.06
53	89	46	51.69	43	48.31
54	89	39	43.82	50	56.18
55	89	31	34.83	58	65.17
56	89	30	33.71	59	66.29
57	89	30	33.71	59	66.29
58	89	33	37.08	56	62.92
59	89	39	43.82	50	56.18
60	87	31	35.63	56	64.37
61	87	31	35.63	56	64.37
62	87	37	42.53	50	57.47
63	87	42	48.28	45	51.72
64	87	33	37.93	54	62.07
65	89	47	52.81	42	47.19
66	89	55	61.80	34	38.20
67	89	50	56.18	39	43.82
68	89	48	53.93	41	46.07
69	89	52	58.43	37	41.57
70	89	52	58.43	37	41.57

71	89	51	57.30	38	42.70
72	89	54	60.67	35	39.33
73	89	39	43.82	50	56.18
74	89	40	44.94	49	55.06
75	89	48	53.93	41	46.07
76	89	34	38.20	55	61.80
77	89	41	46.07	48	53.93
78	89	51	57.30	38	42.70
79	89	36	40.45	53	59.55
80	89	39	43.82	50	56.18
81	89	40	44.94	49	55.06
82	89	35	39.33	54	60.67
83	89	37	41.57	52	58.43
84	89	50	56.18	39	43.82
85	89	35	39.33	54	60.67
86	89	38	42.70	51	57.30
87	89	41	46.07	48	53.93
88	89	32	35.96	57	64.04
89	89	32	35.96	57	64.04
90	89	38	42.70	51	57.30
91	89	23	25.84	66	74.16
92	89	35	39.33	54	60.67
93	89	34	38.20	55	61.80
94	89	29	32.58	60	67.42
95	89	27	30.34	62	69.66
96	89	33	37.08	56	62.92
97	89	21	23.60	68	76.40
98	89	28	31.46	61	68.54
99	89	36	40.45	53	59.55
100	89	22	24.72	67	75.28
101	89	26	29.21	63	70.79
102	89	26	29.21	63	70.79
103	89	14	15.73	75	84.27
104	89	21	23.60	68	76.40
105	89	20	22.47	69	77.53
106	89	13	14.61	76	85.39
107	89	11	12.36	78	87.64
108	89	15	16.85	74	83.15
109	89	13	14.61	76	85.39
110	89	12	13.48	77	86.52
111	89	18	20.22	71	79.78
112	89	14	15.73	75	84.27
113	89	12	13.48	77	86.52
114	89	21	23.60	68	76.40
115	89	15	16.85	74	83.15
116	89	21	23.60	68	76.40
117	89	23	25.84	66	74.16

Classification report 3 of 3

IHO statistics a/b are : 1.000 0.023

User#	Total	# fail	% fail	# pass	% pass
=====	=====	=====	=====	=====	=====
10	89	1	1.12	88	98.88
11	89	0	0.00	89	100.00
12	89	2	2.25	87	97.75
13	88	1	1.14	87	98.86
14	88	0	0.00	88	100.00
15	87	4	4.60	83	95.40
16	89	4	4.49	85	95.51
17	89	9	10.11	80	89.89
18	89	8	8.99	81	91.01
19	89	5	5.62	84	94.38
20	89	19	21.35	70	78.65
21	89	14	15.73	75	84.27
22	89	10	11.24	79	88.76
23	89	29	32.58	60	67.42
24	89	32	35.96	57	64.04
25	88	17	19.32	71	80.68
26	88	47	53.41	41	46.59
27	88	41	46.59	47	53.41
28	86	29	33.72	57	66.28
29	89	38	42.70	51	57.30
30	89	17	19.10	72	80.90
31	89	20	22.47	69	77.53
32	89	4	4.49	85	95.51
33	89	3	3.37	86	96.63
34	89	4	4.49	85	95.51
35	89	2	2.25	87	97.75
36	89	11	12.36	78	87.64
37	89	4	4.49	85	95.51
38	89	4	4.49	85	95.51
39	89	13	14.61	76	85.39
40	89	7	7.87	82	92.13
41	89	8	8.99	81	91.01
42	89	7	7.87	82	92.13
43	89	7	7.87	82	92.13
44	89	4	4.49	85	95.51
45	89	5	5.62	84	94.38
46	89	7	7.87	82	92.13
47	89	10	11.24	79	88.76
48	89	9	10.11	80	89.89
49	89	14	15.73	75	84.27
50	89	13	14.61	76	85.39
51	89	13	14.61	76	85.39
52	89	14	15.73	75	84.27
53	89	15	16.85	74	83.15
54	89	13	14.61	76	85.39
55	89	10	11.24	79	88.76
56	89	10	11.24	79	88.76
57	89	14	15.73	75	84.27
58	89	12	13.48	77	86.52
59	89	11	12.36	78	87.64
60	87	11	12.64	76	87.36
61	87	10	11.49	77	88.51
62	87	18	20.69	69	79.31
63	87	18	20.69	69	79.31
64	87	8	9.20	79	90.80
65	89	14	15.73	75	84.27
66	89	19	21.35	70	78.65
67	89	16	17.98	73	82.02
68	89	12	13.48	77	86.52
69	89	16	17.98	73	82.02
70	89	21	23.60	68	76.40

71	89	13	14.61	76	85.39
72	89	18	20.22	71	79.78
73	89	16	17.98	73	82.02
74	89	15	16.85	74	83.15
75	89	13	14.61	76	85.39
76	89	14	15.73	75	84.27
77	89	8	8.99	81	91.01
78	89	12	13.48	77	86.52
79	89	12	13.48	77	86.52
80	89	8	8.99	81	91.01
81	89	13	14.61	76	85.39
82	89	9	10.11	80	89.89
83	89	7	7.87	82	92.13
84	89	8	8.99	81	91.01
85	89	6	6.74	83	93.26
86	89	4	4.49	85	95.51
87	89	7	7.87	82	92.13
88	89	6	6.74	83	93.26
89	89	5	5.62	84	94.38
90	89	2	2.25	87	97.75
91	89	3	3.37	86	96.63
92	89	5	5.62	84	94.38
93	89	6	6.74	83	93.26
94	89	8	8.99	81	91.01
95	89	5	5.62	84	94.38
96	89	5	5.62	84	94.38
97	89	5	5.62	84	94.38
98	89	4	4.49	85	95.51
99	89	7	7.87	82	92.13
100	89	1	1.12	88	98.88
101	89	3	3.37	86	96.63
102	89	4	4.49	85	95.51
103	89	0	0.00	89	100.00
104	89	0	0.00	89	100.00
105	89	0	0.00	89	100.00
106	89	0	0.00	89	100.00
107	89	0	0.00	89	100.00
108	89	1	1.12	88	98.88
109	89	0	0.00	89	100.00
110	89	1	1.12	88	98.88
111	89	1	1.12	88	98.88
112	89	1	1.12	88	98.88
113	89	1	1.12	88	98.88
114	89	0	0.00	89	100.00
115	89	3	3.37	86	96.63
116	89	1	1.12	88	98.88
117	89	3	3.37	86	96.63

Leadline RA 6S (located in 1015)
 calibrated 3/11/2004

Meter Marks	Measurement	Corrector
1.0	1.0	0.0
2.0	2.0	0.0
3.0	3.0	0.0
4.0	4.0	0.0
5.0	5.0	0.0
6.0	6.0	0.0
7.0	7.0	0.0
8.0	8.0	0.0
9.0	9.0	0.0
10.0	10.0	0.0
11.0	11.0	0.0
12.0	12.0	0.0
13.0	13.0	0.0
14.0	14.0	0.0
15.0	15.0	0.0
16.0	16.0	0.0
Average Correction		0.000
Standard deviation		0.000

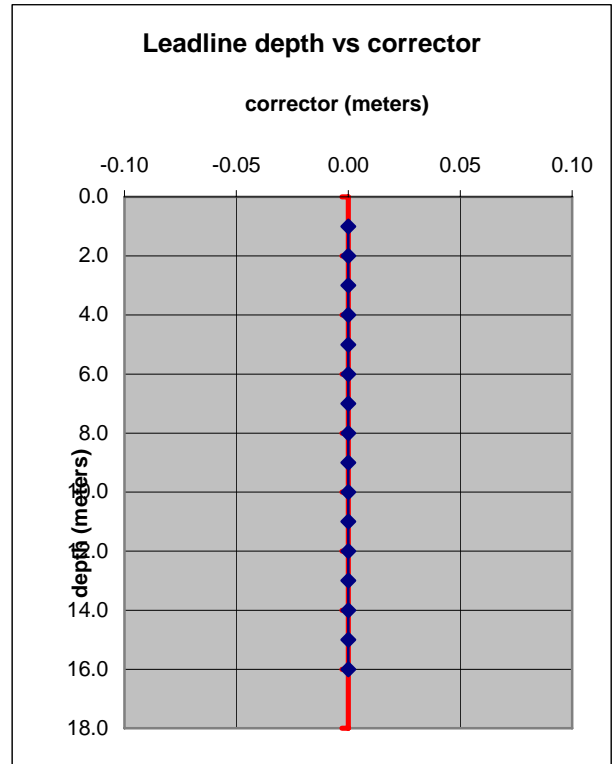

Note: Markers on leadline RA 6S were retied in exact locations

Leadline RA204 (*unlabeled*, located in 1101)

calibrated 3/11/2004

Meter Mark	Measurement	Corrector
1.0	1.000	0.000
2.0	2.000	0.000
3.0	3.000	0.000
4.0	4.000	0.000
5.0	5.000	0.000
6.0	6.000	0.000
7.0	7.000	0.000
8.0	8.000	0.000
9.0	9.000	0.000
10.0	10.000	0.000
11.0	11.000	0.000
12.0	12.000	0.000
13.0	13.000	0.000
14.0	14.000	0.000
15.0	15.000	0.000
16.0	16.000	0.000
17.0	17.000	0.000
18.0	18.000	0.000
19.0	19.000	0.000
20.0	20.000	0.000
21.0	21.000	0.000
22.0	22.000	0.000
23.0	23.000	0.000
24.0	24.000	0.000
25.0	25.000	0.000
Average Correction		0.000
Standard deviation		0.000

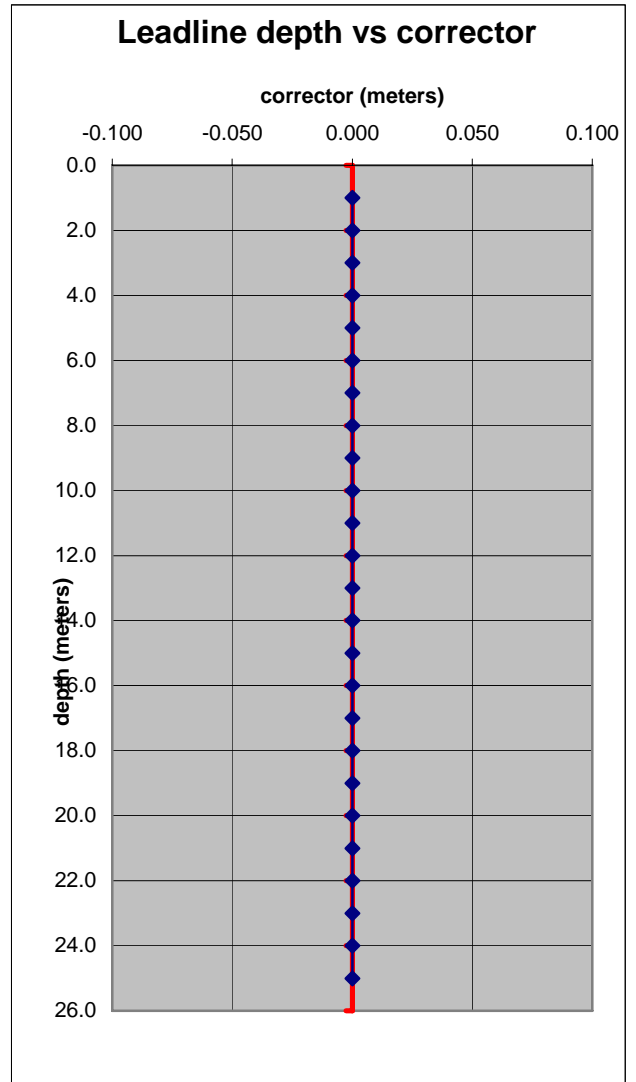

Note: Markers on RA204 were retied in exact 1 m increments

Lead Line RA107 (located in 817)
 calibrated 3/11/2004

Meter Mark	Measurement	Corrector
1.0	1.0	0.0
2.0	2.0	0.0
3.0	3.0	0.0
4.0	4.0	0.0
5.0	5.0	0.0
6.0	6.0	0.0
7.0	7.0	0.0
8.0	8.0	0.0
9.0	9.0	0.0
10.0	10.0	0.0
11.0	11.0	0.0
12.0	12.0	0.0
13.0	13.0	0.0
14.0	14.0	0.0
15.0	15.0	0.0
16.0	16.0	0.0
17.0	17.0	0.0
18.0	18.0	0.0
19.0	19.0	0.0
20.0	20.0	0.0
Average Correction		0.000
Standard deviation		0.000

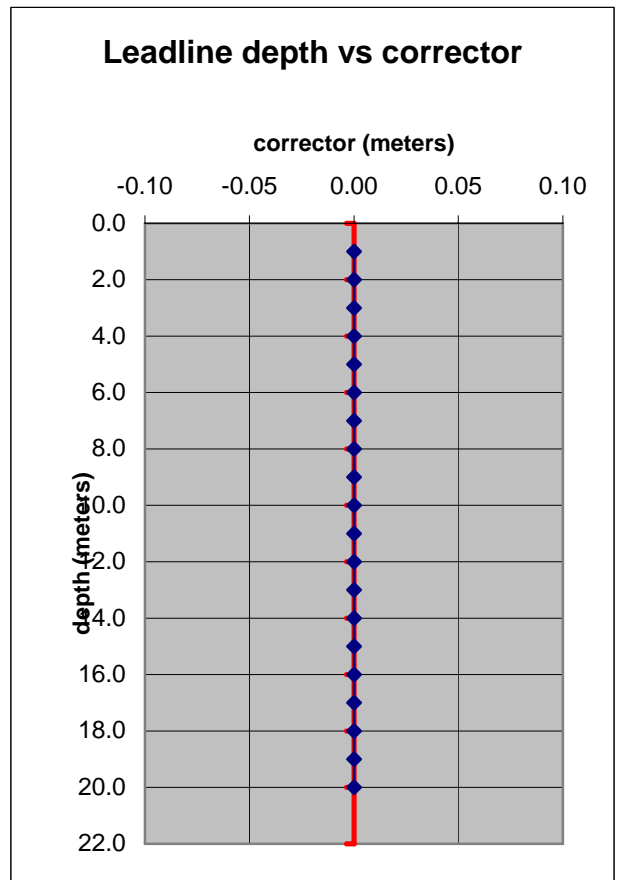

Note: Markers on leadline RA107 were retied in exact 1 m increments

Lead Line RA201 (located on 1103)

calibrated 3/11/2004

Meter Mark	Measurement	Corrector
1.0	1.065	-0.065
2.0	1.995	0.005
3.0	2.975	0.025
4.0	3.965	0.035
5.0	4.975	0.025
6.0	5.963	0.037
7.0	6.970	0.030
8.0	7.963	0.037
9.0	8.992	0.008
10.0	10.010	-0.010
11.0	10.985	0.015
12.0	11.980	0.020
13.0	12.993	0.007
14.0	13.995	0.005
15.0	15.002	-0.002
16.0	16.048	-0.048
17.0	17.057	-0.057
18.0	18.048	-0.048
19.0	19.060	-0.060
20.0	20.059	-0.059
21.0	21.073	-0.073
22.0	22.072	-0.072
23.0	23.070	-0.070
24.0	24.075	-0.075
25.0	25.062	-0.062
Average Correction		-0.018
Standard deviation		0.042

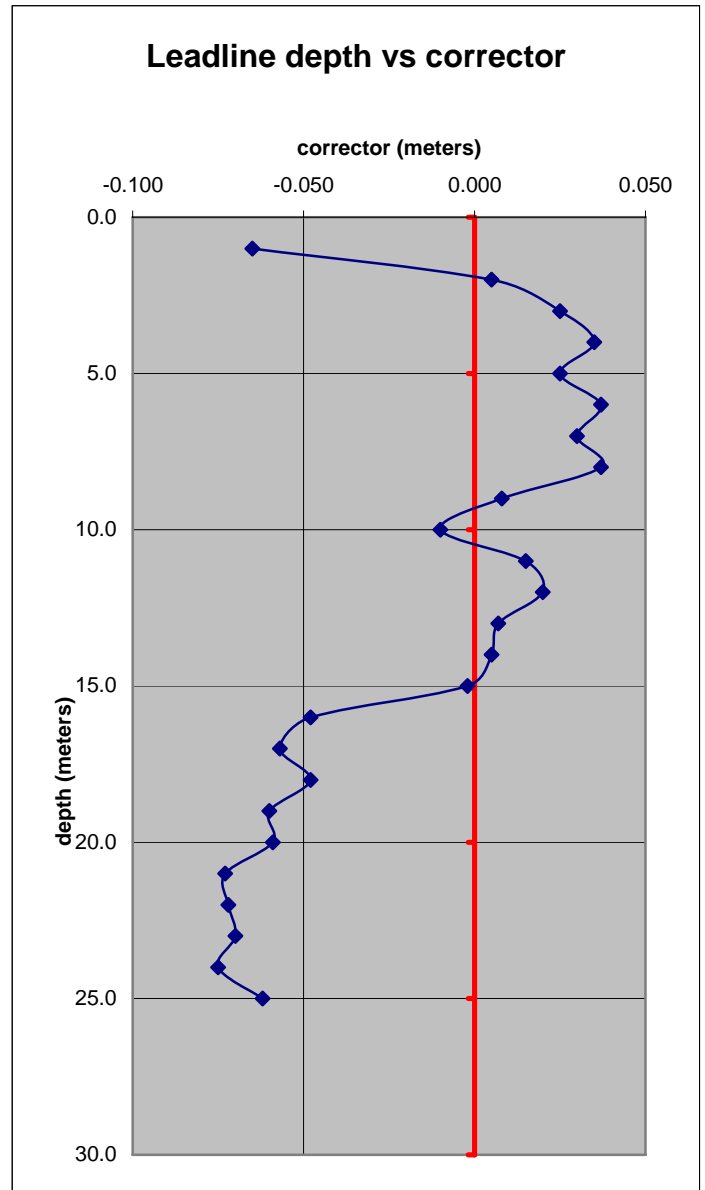

Lead Line RA3 S

calibrated 3/11/2004

Meter Marks	Measurement	Corrector
1.00	1.00	0.00
2.00	2.00	0.00
3.00	3.00	0.00
4.00	4.00	0.00
5.00	5.00	0.00
6.00	6.00	0.00
7.00	7.00	0.00
8.00	8.00	0.00
Average Correction		0.000
Standard deviation		0.000

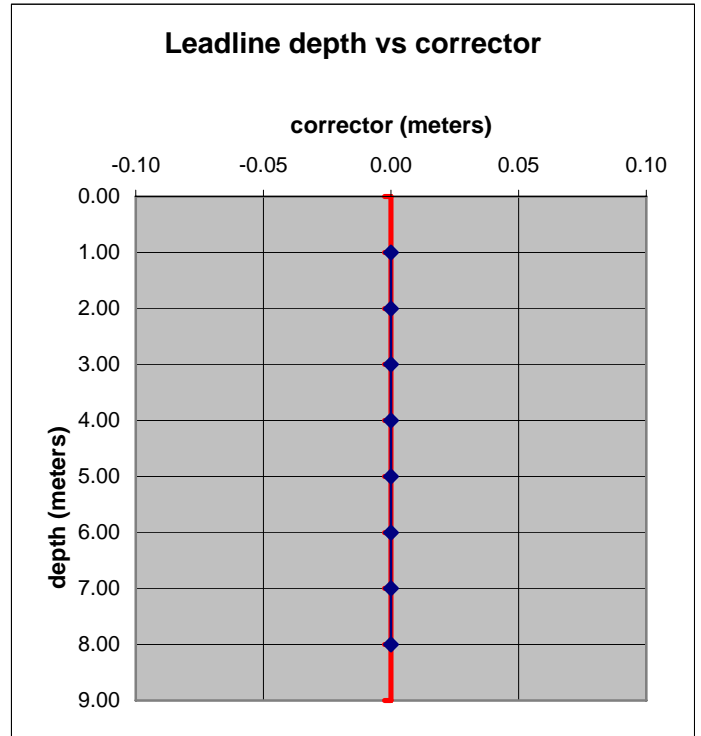

Note: The markers on RA 3 S were retied in exact 1 m increments

Lead Line RA203

calibrated 3/11/2004

Meter Mark	Measurement	Corrector
1.0	1.0	0.0
2.0	2.0	0.0
3.0	3.0	0.0
4.0	4.0	0.0
5.0	5.0	0.0
6.0	6.0	0.0
7.0	7.0	0.0
8.0	8.0	0.0
9.0	9.0	0.0
10.0	10.0	0.0
11.0	11.0	0.0
12.0	12.0	0.0
13.0	13.0	0.0
14.0	14.0	0.0
15.0	15.0	0.0
16.0	16.0	0.0
17.0	17.0	0.0
18.0	18.0	0.0
19.0	19.0	0.0
20.0	20.0	0.0
Average Correction		0.000
Standard deviation		0.000

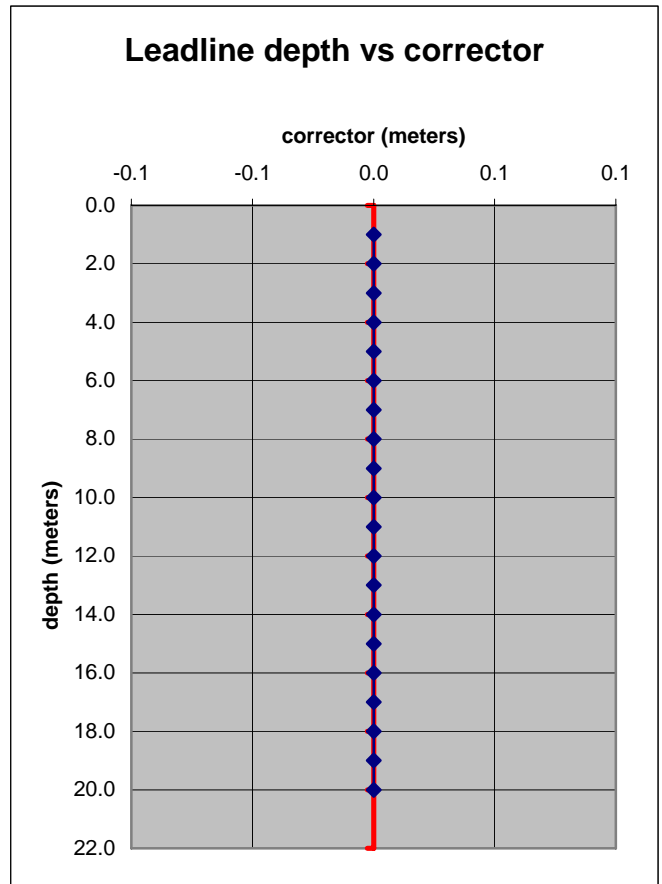

Note: Markers on leadline RA203 were retied in exact 1 m increments