

Table of Contents

A Equipment	1
A.1 Survey Vessels	1
A.1.1 S3001	1
A.1.2 S3004	3
A.2 Echo Sounding Equipment	5
A.2.1 Side Scan Sonars	5
A.2.1.1 Klein 5000 lightweight	6
A.2.1.2 Edgetech 4125	6
A.2.2 Multibeam Echosounders	8
A.2.2.1 Reson 8125 Seabat	8
A.2.3 Single Beam Echosounders	9
A.2.3.1 Odom Echotrac CV200	9
A.2.4 Phase Measuring Bathymetric Sonars	9
A.2.5 Other Echosounders	10
A.3 Manual Sounding Equipment	10
A.3.1 Diver Depth Gauges	10
A.3.2 Lead Lines	10
A.3.3 Sounding Poles	10
A.3.4 Other Manual Sounding Equipment	10
A.4 Positioning and Attitude Equipment	11
A.4.1 Applanix POS/MV	11
A.4.2 DGPS	14
A.4.3 Trimble Backpacks	15
A.4.4 Laser Rangefinders	15
A.4.5 Other Positioning and Attitude Equipment	15
A.5 Sound Speed Equipment	15
A.5.1 Sound Speed Profiles	15
A.5.1.1 CTD Profilers	15
A.5.1.1.1 Sea-Bird Electronics SBE19	15
A.5.1.2 Sound Speed Profilers	16
A.5.1.2.1 Odom Digibar	16
A.5.2 Surface Sound Speed	17
A.6 Horizontal and Vertical Control Equipment	17
A.6.1 Horizontal Control Equipment	17
A.6.2 Vertical Control Equipment	17
A.7 Computer Hardware and Software	18
A.7.1 Computer Hardware	18

A.7.2 Computer Software	18
A.8 Bottom Sampling Equipment	21
A.8.1 Bottom Samplers	21
A.8.1.1 unknown unknown	21
B Quality Control	21
B.1 Data Acquisition	21
B.1.1 Bathymetry	21
B.1.2 Imagery	22
B.1.3 Sound Speed	22
B.1.4 Horizontal and Vertical Control	23
B.1.5 Feature Verification	23
B.1.6 Bottom Sampling	23
B.1.7 Backscatter	23
B.1.8 Other	23
B.2 Data Processing	24
B.2.1 Bathymetry	24
B.2.2 Imagery	30
B.2.3 Sound Speed	33
B.2.4 Horizontal and Vertical Control	35
B.2.5 Feature Verification	36
B.2.6 Backscatter	37
B.2.7 Other	37
B.3 Quality Management	37
B.4 Uncertainty and Error Management	37
B.4.1 Total Propagated Uncertainty (TPU)	38
B.4.2 Deviations	40
C Corrections To Echo Soundings	40
C.1 Vessel Offsets and Layback	40
C.1.1 Vessel Offsets	40
C.1.2 Layback	41
C.2 Static and Dynamic Draft	41
C.2.1 Static Draft	41
C.2.2 Dynamic Draft	41
C.3 System Alignment	42
C.4 Positioning and Attitude	44

[C.5 Tides and Water Levels](#)44

[C.6 Sound Speed](#) 44

[C.6.1 Sound Speed Profiles](#)44

[C.6.2 Surface Sound Speed](#)45

Data Acquisition and Processing Report

NRT1

Chief of Party: Mark McMann

Year: 2014

Version: 1

Publish Date: 2014-05-27

A Equipment

A.1 Survey Vessels

A.1.1 S3001

<i>Name</i>	S3001	
<i>Hull Number</i>	S3001	
<i>Description</i>	Sea Ark Commander 30'	
<i>Utilization</i>	Survey vessel	
<i>Dimensions</i>	<i>LOA</i>	9.15 meters
	<i>Beam</i>	2.45 meters
	<i>Max Draft</i>	0.5 meters
<i>Most Recent Full Static Survey</i>	<i>Date</i>	2013-03-19
	<i>Performed By</i>	Buchanan and Harper, Surveyors, Panama City, FL.
	<i>Discussion</i>	Offset survey values entered in Caris
<i>Most Recent Partial Static Survey</i>	Partial static survey was not performed.	
<i>Most Recent Full Offset Verification</i>	<i>Date</i>	2013-03-19
	<i>Method Used</i>	Total Station
	<i>Discussion</i>	by Buchanan and Harper, Surveyors, Panama City, FL.
<i>Most Recent Partial Offset Verification</i>	Partial offset verification was not performed.	

<i>Most Recent Static Draft Determination</i>	<i>Date</i>	2013-05-20
	<i>Method Used</i>	Lead Line Method
	<i>Discussion</i>	by NRT1 personnel
<i>Most Recent Dynamic Draft Determination</i>	<i>Date</i>	2014-04-21
	<i>Method Used</i>	Multibeam sonar surface comparison method
	<i>Discussion</i>	by NRT1 personnel

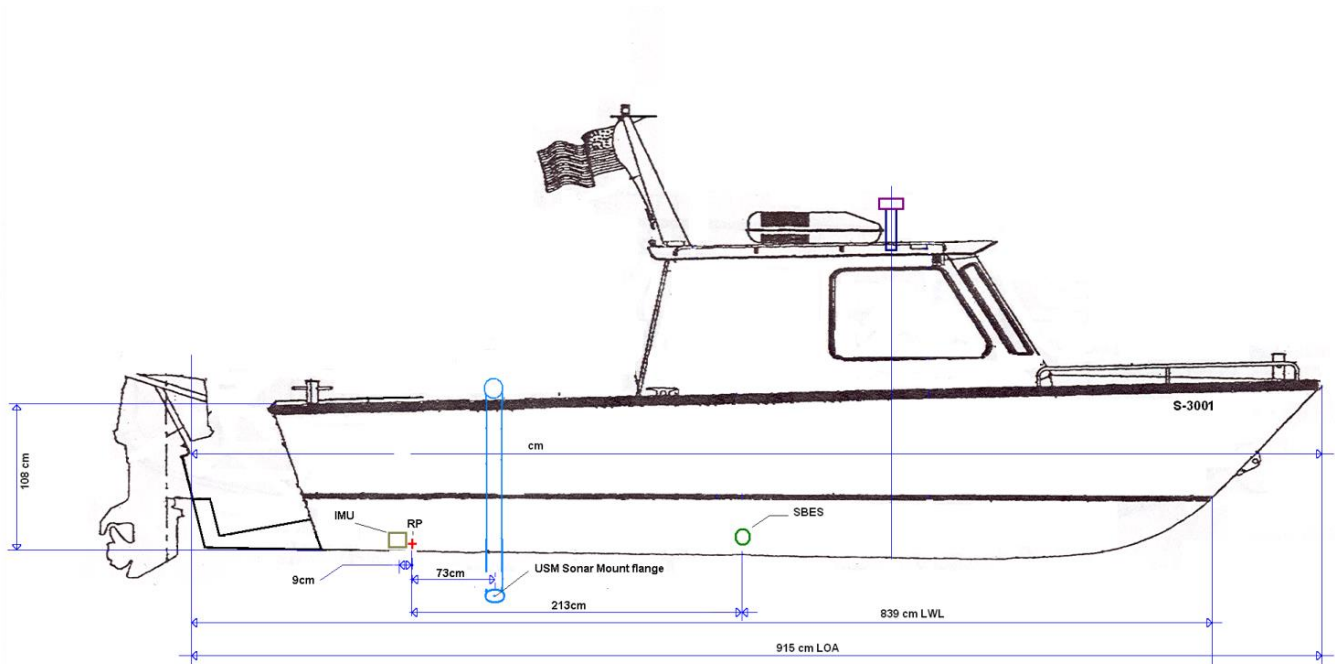

S3001 Schematics- Side View

Figure 1: S3001 Schematics, Side View

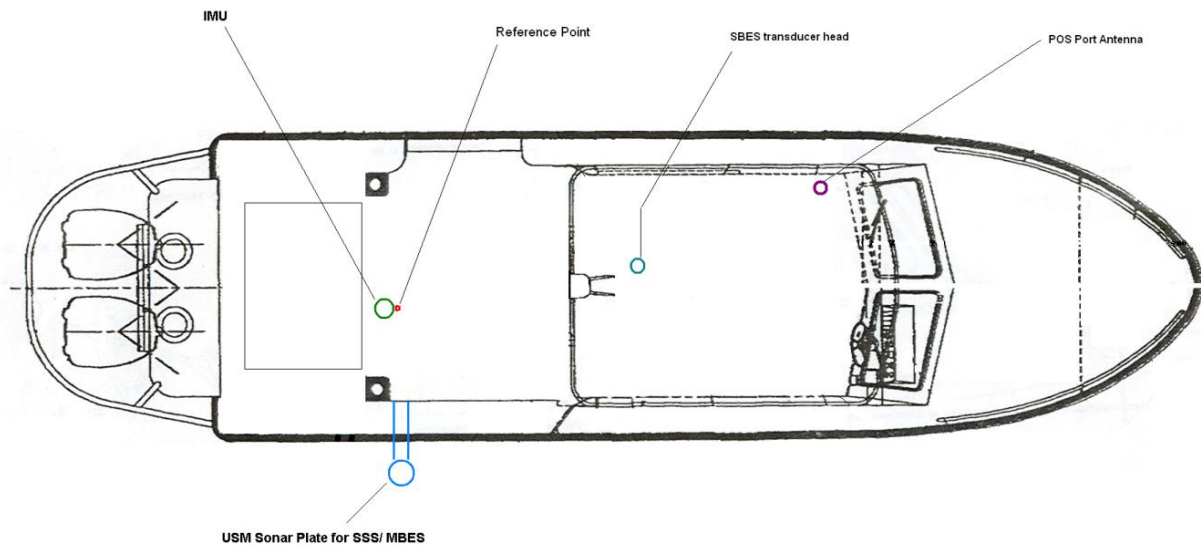

S3001 Schematics - Top View

Figure 2: S3001 Schematics, Top View

A.1.2 S3004

<i>Name</i>	S3004	
<i>Hull Number</i>	S3004	
<i>Description</i>	Sea Ark Commander 30'	
<i>Utilization</i>	Survey Vessel	
<i>Dimensions</i>	<i>LOA</i>	9.15 meters
	<i>Beam</i>	2.45 meters
	<i>Max Draft</i>	0.5 meters
<i>Most Recent Full Static Survey</i>	<i>Date</i>	2009-06-03
	<i>Performed By</i>	NOAA NGS
	<i>Discussion</i>	Offset survey values entered in Caris
<i>Most Recent Partial Static Survey</i>	Partial static survey was not performed.	

<i>Most Recent Full Offset Verification</i>	<i>Date</i>	2013-06-06
	<i>Method Used</i>	Total Station
	<i>Discussion</i>	by NOAA NGS
<i>Most Recent Partial Offset Verification</i>	Partial offset verification was not performed.	
<i>Most Recent Static Draft Determination</i>	<i>Date</i>	2012-03-05
	<i>Method Used</i>	Lead Line
	<i>Discussion</i>	by NRT1 personnel
<i>Most Recent Dynamic Draft Determination</i>	<i>Date</i>	2012-05-10
	<i>Method Used</i>	Multibeam sonar surfaces comparison method
	<i>Discussion</i>	by NRT1 personnel

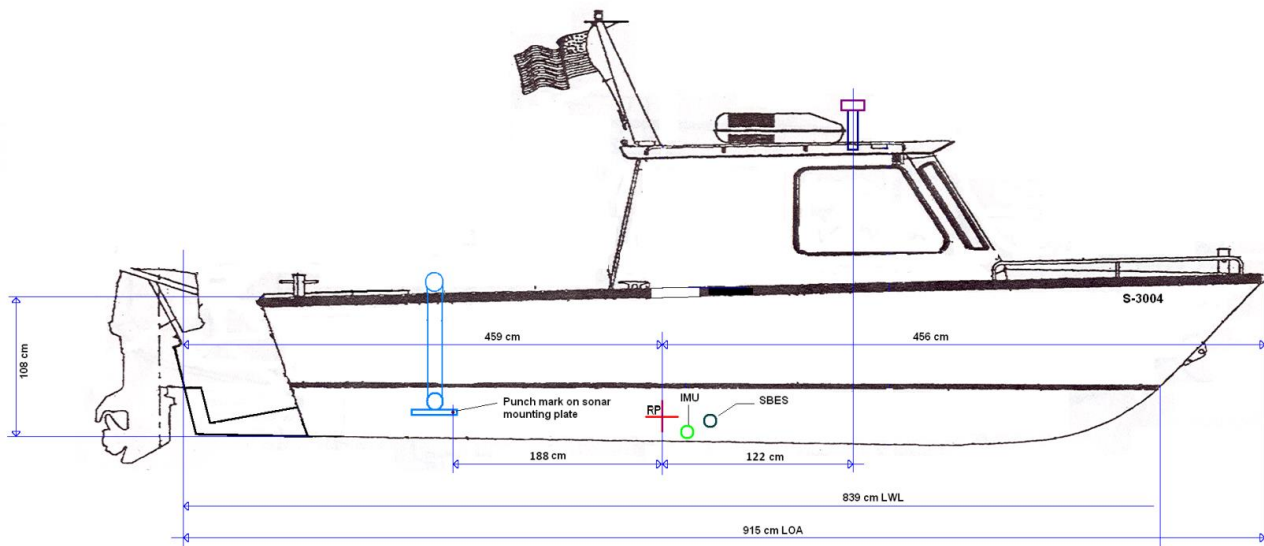

S-3004 Schematics-Side View

Figure 3: S3004 Schematics, Side View

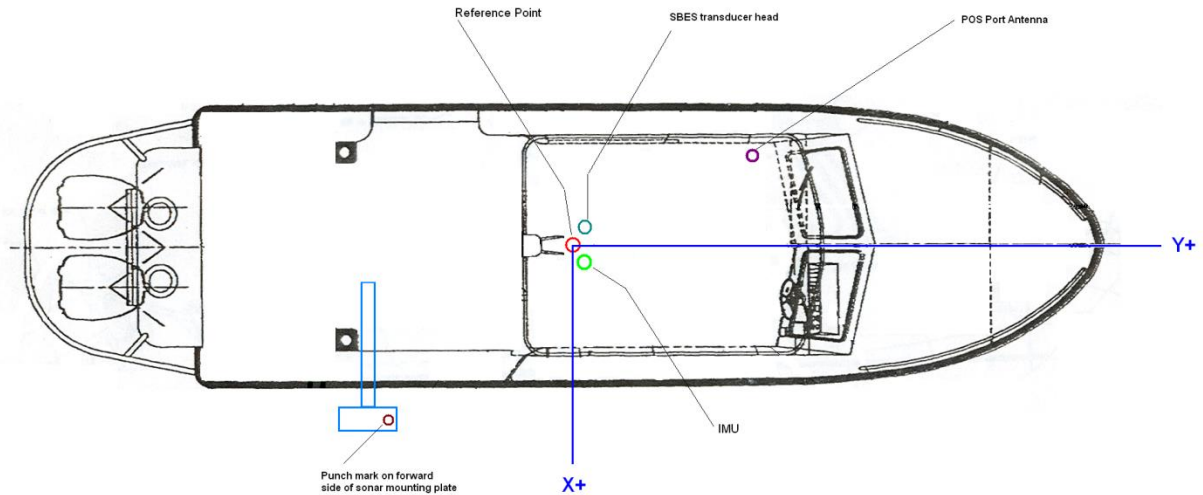

S-3004 Schematics-Top View

Figure 4: S3001 Schematics, Top View

Additional Discussion

Survey vessel S3004 was used as a surveying platform until 01/28/2013. After that date, all survey data collection have been done onboard survey vessel S3001.

A.2 Echo Sounding Equipment

A.2.1 Side Scan Sonars

A.2.1.1 Klein 5000 lightweight

<i>Manufacturer</i>	Klein		
<i>Model</i>	5000 lightweight		
<i>Description</i>	pole mounted SSS		
<i>Serial Numbers</i>	<i>Vessel Installed On</i>	S3004	SAMA1648H404
	<i>TPU s/n</i>	Klein	SN#157
	<i>Towfish s/n</i>	5000	SN#317
<i>Specifications</i>	<i>Frequency</i>	455 kilohertz	
	<i>Along Track Resolution</i>	<i>Resolution</i>	30 centimeters
		<i>Min Range</i>	50 meters
		<i>Max Range</i>	150 meters
	<i>Across Track Resolution</i>	7.5 centimeters	
<i>Max Range Scale</i>	150 meters		
<i>Manufacturer Calibrations</i>	Manufacturer calibration was not performed.		



Figure 5: Klein 5000 SSS

A.2.1.2 Edgetech 4125

<i>Manufacturer</i>	Edgetech		
<i>Model</i>	4125		
<i>Description</i>	pole mounted SSS		
<i>Serial Numbers</i>	<i>Vessel Installed On</i>	S3004 and S3001	SAMA1648H404 (S3004) and SAMA1355E202 (S3001)
	<i>TPU s/n</i>	Edgetech TPU	SN#40259
	<i>Towfish s/n</i>	Model 4125	SN# 40424
<i>Specifications</i>	<i>Frequency</i>	900 kilohertz	
	<i>Along Track Resolution</i>	<i>Resolution</i>	27 centimeters
		<i>Min Range</i>	35 meters
		<i>Max Range</i>	150 meters
	<i>Across Track Resolution</i>	1.5 centimeters	
<i>Max Range Scale</i>	150 meters		
<i>Manufacturer Calibrations</i>	Manufacturer calibration was not performed.		



Figure 6: Edgetech 4125 SSS

A.2.2 Multibeam Echosounders

A.2.2.1 Reson 8125 Seabat

<i>Manufacturer</i>	Reson			
<i>Model</i>	8125 Seabat			
<i>Description</i>	Pole mounted MBES			
<i>Serial Numbers</i>	<i>Vessel Installed On</i>	SAMA1648H404 (S3004) and SAMA1355E202 (S3001)		
	<i>Processor s/n</i>	SN# 31546		
	<i>Transceiver s/n</i>	N/A		
	<i>Transducer s/n</i>	SN# 0802092		
	<i>Receiver s/n</i>	N/A		
	<i>Projector 1 s/n</i>	None		
	<i>Projector 2 s/n</i>	None		
<i>Specifications</i>	<i>Frequency</i>	455 kilohertz		
	<i>Beamwidth</i>	<i>Along Track</i>	1 degrees	
		<i>Across Track</i>	0.5 degrees	
	<i>Max Ping Rate</i>	40 hertz		
	<i>Beam Spacing</i>	<i>Beam Spacing Mode</i>	Equidistant	
		<i>Number of Beams</i>	240	
	<i>Max Swath Width</i>	120 degrees		
	<i>Depth Resolution</i>	6 millimeters		
	<i>Depth Rating</i>	<i>Manufacturer Specified</i>	400 meters	
<i>Ship Usage</i>		0.6 meters		
<i>Manufacturer Calibrations</i>	Manufacturer calibration was not performed.			
<i>System Accuracy Tests</i>	<i>Vessel Installed On</i>	S3001	S3001	
	<i>Methods</i>	Calibration Patch Test	Calibration Patch Test	
	<i>Results</i>	accepted	accepted	
<i>Snippets</i>	Sonar does not have snippets logging capability.			



Figure 7: Reson 8125 MBES

A.2.3 Single Beam Echosounders

A.2.3.1 Odom Echotrac CV200

<i>Manufacturer</i>	Odom		
<i>Model</i>	Echotrac CV200		
<i>Description</i>	Single Beam Echo Sounder		
<i>Serial Numbers</i>	<i>Vessel</i>	S3001	
	<i>Processor s/n</i>	SN#23019	
	<i>Transducer s/n</i>	N/A	
<i>Specifications</i>	<i>Frequency</i>	100 kilohertz	
	<i>Beamwidth</i>	<i>Along Track</i>	3 degrees
		<i>Across Track</i>	3 degrees
	<i>Max Ping Rate</i>	20 hertz	
	<i>Depth Resolution</i>	0.01 meters	
	<i>Depth Rating</i>	<i>Manufacturer Specified</i>	15 meters
<i>Ship Usage</i>		0.5 meters	
<i>Manufacturer Calibrations</i>	Manufacturer calibration was not performed.		
<i>System Accuracy Tests</i>	<i>Vessel Installed On</i>	S3001	
	<i>Methods</i>	Sounding Systems Comparison	
	<i>Results</i>	accepted	

A.2.4 Phase Measuring Bathymetric Sonars

No phase measuring bathymetric sonars were utilized for data acquisition.

A.2.5 Other Echosounders

No additional echosounders were utilized for data acquisition.

A.3 Manual Sounding Equipment

A.3.1 Diver Depth Gauges

No diver depth gauges were utilized for data acquisition.

A.3.2 Lead Lines

<i>Manufacturer</i>	unknown	
<i>Model</i>	unknown	
<i>Description</i>		
<i>Serial Numbers</i>	NRT1-LL	
<i>Calibrations</i>	<i>Serial Number</i>	NRT1-LL
	<i>Date</i>	2013-05-20
	<i>Procedures</i>	manual calibration
<i>Accuracy Checks</i>	No accuracy checks were performed.	
<i>Correctors</i>	Correctors were not determined.	
<i>Non-Standard Procedures</i>	Non-standard procedures were not utilized.	

A.3.3 Sounding Poles

No sounding poles were utilized for data acquisition.

A.3.4 Other Manual Sounding Equipment

No additional manual sounding equipment was utilized for data acquisition.

A.4 Positioning and Attitude Equipment

A.4.1 Applanix POS/MV

<i>Manufacturer</i>	Trimble Applanix			
<i>Model</i>	POS MV 4			
<i>Description</i>				
<i>PCS</i>	<i>Manufacturer</i>	Trimble Applanix		
	<i>Model</i>	POS MV 4		
	<i>Description</i>			
	<i>Firmware Version</i>	320		
	<i>Software Version</i>	3.4.0		
	<i>Serial Numbers</i>	<i>Vessel Installed On</i>	S3004 and S3001	
<i>PCS s/n</i>		SN#2233		
<i>IMU</i>	<i>Manufacturer</i>	Trimble Applanix		
	<i>Model</i>	POS MV 4		
	<i>Description</i>	IMU		
	<i>Serial Numbers</i>	<i>Vessel Installed On</i>	S3004 and S3001	
		<i>IMU s/n</i>	SN#2233	
	<i>Certification</i>	IMU certification report was not produced.		

<i>Antennas</i>	<i>Manufacturer</i>	Trimble			
	<i>Model</i>	Zephyr Mopdel 1			
	<i>Description</i>				
	<i>Serial Numbers</i>	<i>Vessel Installed On</i>	S3004	S3004	
		<i>Antenna s/n</i>	SN 60008125	SN 60145271	
<i>Port or Starboard</i>		Port	Starboard		
<i>Primary or Secondary</i>		Primary	Secondary		
<i>GAMS Calibration</i>	<i>Vessel</i>	S3004			
	<i>Calibration Date</i>	2012-02-28			
<i>Configuration Reports</i>	<i>Vessel</i>	S3004, please see NVM file in \H12357\Field Products\Multimedia \Images\posconfig02282012.nvm			
	<i>Report Date</i>	2012-02-28			



Figure 8: POS MV 4

<i>Manufacturer</i>	Trimble Applanix			
<i>Model</i>	POS MV 5			
<i>Description</i>				
<i>PCS</i>	<i>Manufacturer</i>	Trimble Applanix		
	<i>Model</i>	POS MV 5		
	<i>Description</i>			
	<i>Firmware Version</i>	unknown		
	<i>Software Version</i>	7.60		
	<i>Serial Numbers</i>	<i>Vessel Installed On</i>	S3001	
<i>PCS s/n</i>		SN#5847		
<i>IMU</i>	<i>Manufacturer</i>	Trimble Applanix		
	<i>Model</i>	POS MV 5		
	<i>Description</i>	IMU		
	<i>Serial Numbers</i>	<i>Vessel Installed On</i>	S3001	
		<i>IMU s/n</i>	SN#2425	
	<i>Certification</i>	IMU certification report was not produced.		
<i>Antennas</i>	<i>Manufacturer</i>	Trimble		
	<i>Model</i>	Zephyr model 2		
	<i>Description</i>			
	<i>Serial Numbers</i>	<i>Vessel Installed On</i>	S3001	S3001
		<i>Antenna s/n</i>	SN#144132423	SN#1441132146
		<i>Port or Starboard</i>	Port	Starboard
<i>Primary or Secondary</i>		Primary	Secondary	
<i>GAMS Calibration</i>	<i>Vessel</i>	S3001		
	<i>Calibration Date</i>	2013-07-15		

<i>Configuration Reports</i>	<i>Vessel</i>	S3001, Please see NVM file in \\H12358\Field Products\Multimedia\Images\2014_111_pos_config.nvm
	<i>Report Date</i>	2014-04-21

A.4.2 DGPS

<i>Description</i>	Trimble DGPS Antenna			
<i>Antennas</i>	<i>Manufacturer</i>	Trimble		
	<i>Model</i>	33580-00		
	<i>Description</i>			
	<i>Serial Numbers</i>	<i>Vessel Installed On</i>	S3004	S3001
		<i>Antenna s/n</i>	SN#0220342684	SN#0220342684
<i>Receivers</i>	<i>Manufacturer</i>	Trimble		
	<i>Model</i>	DSM232		
	<i>Description</i>			
	<i>Firmware Version</i>	3.59		
	<i>Serial Numbers</i>	<i>Vessel Installed On</i>	S3004	S3001
<i>Antenna s/n</i>		SN# 0225116712	SN# 0225116712	



Figure 10: Trimble DGPS Receiver DSM 232

A.4.3 Trimble Backpacks

Trimble backpack equipment was not utilized for data acquisition.

A.4.4 Laser Rangefinders

No laser rangefinders were utilized for data acquisition.

A.4.5 Other Positioning and Attitude Equipment

No additional positioning and attitude equipment was utilized for data acquisition.

A.5 Sound Speed Equipment

A.5.1 Sound Speed Profiles

A.5.1.1 CTD Profilers

A.5.1.1.1 Sea-Bird Electronics SBE19

<i>Manufacturer</i>	Sea-Bird Electronics	
<i>Model</i>	SBE19	
<i>Description</i>		
<i>Serial Numbers</i>	<i>Vessel Installed On</i>	S3004
	<i>CTD s/n</i>	SN#0287
<i>Calibrations</i>	<i>CTD s/n</i>	SN#0287
	<i>Date</i>	2013-02-06
	<i>Procedures</i>	Manufacturer calibration



Figure 11: Sea-Bird SBE19 CTD

A.5.1.2 Sound Speed Profilers**A.5.1.2.1 Odom Digibar**

<i>Manufacturer</i>	Odom
<i>Model</i>	Digibar
<i>Description</i>	

<i>Serial Numbers</i>	<i>Vessel Installed On</i>	S3004 and S3001	S3004 and S3001	S3004 and S3001
	<i>Sound Speed Profiler s/n</i>	SN#98294	SN#98527	SN#98376
<i>Calibrations</i>	<i>Sound Speed Profiler s/n</i>	SN#98294	SN#98527	SN#98376
	<i>Date</i>	2014-01-24	2014-01-24	2013-12-23
	<i>Procedures</i>	Manufacturer calibration	Manufacturer calibration	Manufacturer calibration



Figure 12: Odom Digibar Sound Speed Profiler

A.5.2 Surface Sound Speed

No surface sound speed sensors were utilized for data acquisition.

A.6 Horizontal and Vertical Control Equipment

A.6.1 Horizontal Control Equipment

No horizontal control equipment was utilized for data acquisition.

A.6.2 Vertical Control Equipment

No vertical control equipment was utilized for data acquisition.

A.7 Computer Hardware and Software

A.7.1 Computer Hardware

<i>Manufacturer</i>	Dell	
<i>Model</i>	T5500	
<i>Description</i>	desktop	
<i>Serial Numbers</i>	<i>Computer s/n</i>	Service Tag #D0W78U
	<i>Operating System</i>	W7
	<i>Use</i>	Acquisition

<i>Manufacturer</i>	Dell	
<i>Model</i>	T5500	
<i>Description</i>	desktop	
<i>Serial Numbers</i>	<i>Computer s/n</i>	Service tag #D1J78V1
	<i>Operating System</i>	W7
	<i>Use</i>	Processing

<i>Manufacturer</i>	Dell	
<i>Model</i>	T3400	
<i>Description</i>	desktop	
<i>Serial Numbers</i>	<i>Computer s/n</i>	Service tag#JH1J2H1
	<i>Operating System</i>	XP
	<i>Use</i>	Processing

<i>Manufacturer</i>	Dell	
<i>Model</i>	Latitude E6530	
<i>Description</i>	laptop	
<i>Serial Numbers</i>	<i>Computer s/n</i>	Service tag#B4CKFX1
	<i>Operating System</i>	W7
	<i>Use</i>	Processing

A.7.2 Computer Software

<i>Manufacturer</i>	Hypack
<i>Software Name</i>	Hypack
<i>Version</i>	2013
<i>Service Pack</i>	
<i>Hotfix</i>	
<i>Installation Date</i>	2012-12-03
<i>Use</i>	Acquisition
<i>Description</i>	Acquisition Software

<i>Manufacturer</i>	Odom
<i>Software Name</i>	Echart
<i>Version</i>	
<i>Service Pack</i>	
<i>Hotfix</i>	
<i>Installation Date</i>	2012-01-07
<i>Use</i>	Acquisition
<i>Description</i>	Acquisition Software

<i>Manufacturer</i>	Edgetech
<i>Software Name</i>	DiscoverII
<i>Version</i>	06 26 13
<i>Service Pack</i>	
<i>Hotfix</i>	
<i>Installation Date</i>	2013-06-26
<i>Use</i>	Acquisition
<i>Description</i>	Acquisition Software

<i>Manufacturer</i>	Applanix
<i>Software Name</i>	PosView
<i>Version</i>	5
<i>Service Pack</i>	
<i>Hotfix</i>	
<i>Installation Date</i>	2013-07-01
<i>Use</i>	Acquisition

<i>Description</i>	Acquisition Software
<i>Manufacturer</i>	Caris
<i>Software Name</i>	HIPS & SIPS
<i>Version</i>	8
<i>Service Pack</i>	0
<i>Hotfix</i>	1
<i>Installation Date</i>	2013-09-02
<i>Use</i>	Processing
<i>Description</i>	Processing Software
<i>Manufacturer</i>	NOAA
<i>Software Name</i>	Pydro
<i>Version</i>	13.2
<i>Service Pack</i>	r4326
<i>Hotfix</i>	
<i>Installation Date</i>	2013-09-27
<i>Use</i>	Processing
<i>Description</i>	Processing Software
<i>Manufacturer</i>	Pitney Bowes
<i>Software Name</i>	Mapinfo
<i>Version</i>	11
<i>Service Pack</i>	0
<i>Hotfix</i>	4
<i>Installation Date</i>	2013-10-30
<i>Use</i>	Processing
<i>Description</i>	Processing Software
<i>Manufacturer</i>	Odom
<i>Software Name</i>	Digibar Pro
<i>Version</i>	3
<i>Service Pack</i>	0
<i>Hotfix</i>	
<i>Installation Date</i>	2008-01-07

<i>Use</i>	Processing
<i>Description</i>	Processing Software

A.8 Bottom Sampling Equipment

A.8.1 Bottom Samplers

A.8.1.1 unknown unknown

<i>Manufacturer</i>	unknown
<i>Model</i>	unknown
<i>Description</i>	no SN#

B Quality Control

B.1 Data Acquisition

B.1.1 Bathymetry

B.1.1.1 Multibeam Echosounder

Data acquisition was done in agreement with the current Specifications and Deliverables as well as the current Field Procedure Manual.

B.1.1.2 Single Beam Echosounder

Data acquisition was done in agreement with the current Specifications and Deliverables as well as the current Field Procedure Manual.

B.1.1.3 Phase Measuring Bathymetric Sonar

Phase measuring bathymetric sonar bathymetry was not acquired.

B.1.2 Imagery

B.1.2.1 Side Scan Sonar

Data acquisition was done in agreement with the current Specifications and Deliverables as well as the current Field Procedure Manual.

B.1.2.2 Phase Measuring Bathymetric Sonar

Phase measuring bathymetric sonar imagery was not acquired.

B.1.3 Sound Speed

B.1.3.1 Sound Speed Profiles

Data acquisition was done in agreement with the current Specifications and Deliverables as well as the current Field Procedure Manual.

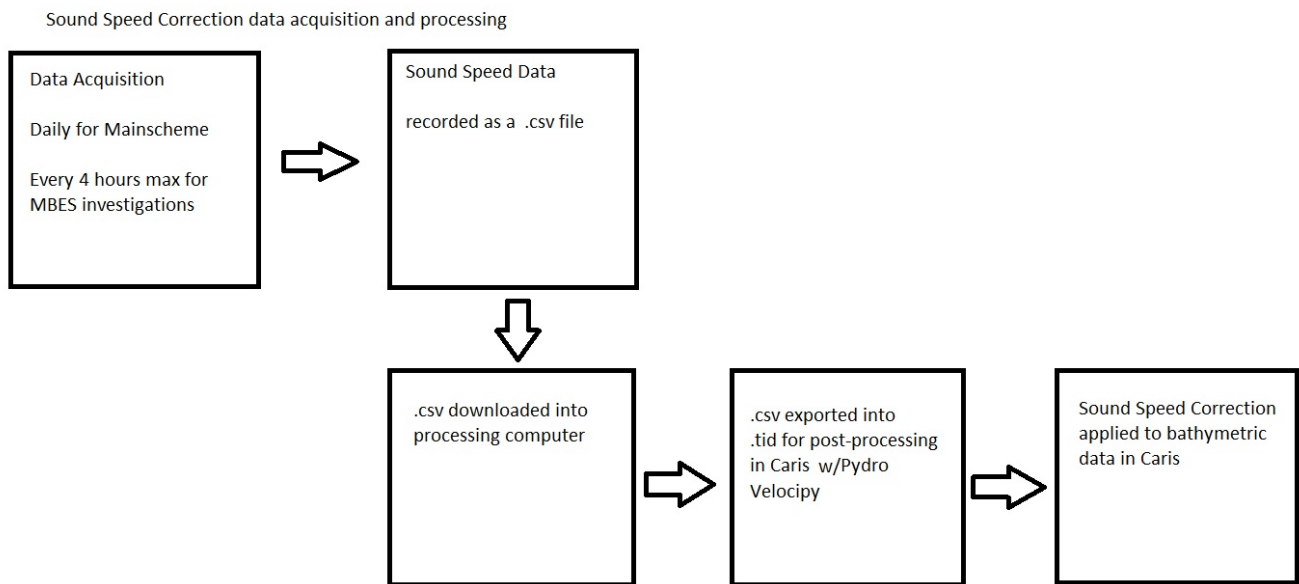

Figure 13: Sound Speed Corrections Process

B.1.3.2 Surface Sound Speed

Data acquisition was done in agreement with the current Specifications and Deliverables as well as the current Field Procedure Manual.

B.1.4 Horizontal and Vertical Control

B.1.4.1 Horizontal Control

Data acquisition was done in agreement with the current Specifications and Deliverables as well as the current Field Procedure Manual.

B.1.4.2 Vertical Control

Data acquisition was done in agreement with the current Specifications and Deliverables as well as the current Field Procedure Manual.

B.1.5 Feature Verification

Data acquisition was done in agreement with the current Specifications and Deliverables as well as the current Field Procedure Manual.

B.1.6 Bottom Sampling

Data acquisition was done in agreement with the current Specifications and Deliverables as well as the current Field Procedure Manual.

B.1.7 Backscatter

Backscatter data were not acquired.

B.1.8 Other

No additional data were acquired.

B.2 Data Processing

B.2.1 Bathymetry

B.2.1.1 Multibeam Echosounder

NOAA hydrographic field units typically acquire bathymetric data using VBES, MBES, or a combination of both.

VBES depths are processed using the CARIS HIPS Single Beam Editor tool to review and edit data anomalies.

MBES data may be edited in two different ways: using CARIS HIPS Swath Editor tool to edit data in a time-series

mode, or using the CARIS HIPS Subset Editor tool to edit data in a spatial mode. In both instances, Bathymetry

Associated with Statistical Error (BASE) methods are used to generate, using one or more different algorithms, a

digital seafloor model that contains depth and uncertainty information at each model node. In addition to the basic bathymetric layer, auxiliary information layers such as standard deviation of soundings, sounding density,

shoal depth, source identification, hypothesis count, and hypothesis strength will be generated depending upon

the algorithm used to construct the BASE surface. These BASE surface layers are used to guide the hydrographer

to areas that require further examination and/or editing.



Figure 14: Multibeam Echosounder

B.2.1.2 Single Beam Echosounder

NOAA hydrographic field units typically acquire bathymetric data using VBES, MBES, or a combination of both.

VBES depths are processed using the CARIS HIPS Single Beam Editor tool to review and edit data anomalies.

MBES data may be edited in two different ways: using CARIS HIPS Swath Editor tool to edit data in a time-series mode, or using the CARIS HIPS Subset Editor tool to edit data in a spatial mode. In both instances, Bathymetry Associated with Statistical Error (BASE) methods are used to generate, using one or more different algorithms, a digital seafloor model that contains depth and uncertainty information at each model node. In addition to the basic bathymetric layer, auxiliary information layers such as standard deviation of soundings, sounding density, shoal depth, source identification, hypothesis count, and hypothesis strength will be generated depending upon the algorithm used to construct the BASE surface. These BASE surface layers are used to guide the hydrographer to areas that require further examination and/or editing.



Figure 15: Vertical Echosounder

B.2.1.3 Phase Measuring Bathymetric Sonar

Phase measuring bathymetric sonar bathymetry was not processed.

B.2.1.4 Specific Data Processing Methods

B.2.1.4.1 Methods Used to Maintain Data Integrity

NOAA hydrographic field units typically acquire bathymetric data using VBES, MBES, or a combination of both.

VBES depths are processed using the CARIS HIPS Single Beam Editor tool to review and edit data anomalies.

MBES data may be edited in two different ways: using CARIS HIPS Swath Editor tool to edit data in a time-series

mode, or using the CARIS HIPS Subset Editor tool to edit data in a spatial mode. In both instances, Bathymetry

Associated with Statistical Error (BASE) methods are used to generate, using one or more different algorithms, a

digital seafloor model that contains depth and uncertainty information at each model node. In addition to the basic bathymetric layer, auxiliary information layers such as standard deviation of soundings, sounding density,

shoal depth, source identification, hypothesis count, and hypothesis strength will be generated depending upon

the algorithm used to construct the BASE surface. These BASE surface layers are used to guide the hydrographer

to areas that require further examination and/or editing.

B.2.1.4.2 Methods Used to Generate Bathymetric Grids

Combined Uncertainty and Bathymetric Estimator (CUBE)

CUBE is a gridding algorithm developed at the University of New Hampshire (UNH)/NOAA Center for Coastal

and Ocean Mapping Joint Hydrographic Center by Dr. Brian Calder. Its primary advantage over uncertainty weighted grids is that it is less susceptible to noise. CUBE works in two stages:

Integration of Soundings into Hypotheses - During the first stage, all soundings in the area are grouped into internally consistent depth hypotheses, using the uncertainty of the soundings as a threshold.

Disambiguation - After all soundings are integrated, a second stage determines which hypothesis at each node is

the most likely to be the seafloor. There are four disambiguation methods available:

(a) The density option selects the hypothesis with the greatest number of sounding samples.

(b) The locale option selects the hypothesis that is most consistent with its surrounding nodes that has only one hypothesis.

(c) The density and locale option selects the hypothesis with the greatest number of soundings and is consistent with neighboring nodes.

(d) The initialization option selects the hypothesis that is closest to an initialization surface created previously.

The CARIS HIPS integration of CUBE is well documented in the CARIS HIPS and SIPS User's Manual.

This manual should be referenced for details on the workings of the algorithm and explanations of the user interface.

When editing a CUBE surface, the user may opt to edit soundings or to edit hypotheses. For NOAA hydrographic

survey data, it is critical that only sounding edits be used to correct gridding problems. This is primarily because

hypothesis edits exist only in the context of a single grid, and will be lost if that grid is recomputed.

CUBE Parameters

There is a small parameter file called "CUBEParams.xml" in the HIPS system directory that is referenced in the

HIPS environment. The values in this file control the behavior of the CUBE gridding and disambiguation processes.

The default CUBE parameters are not authorized for NOAA surveys. Instead, field units shall use the CubeParams_

NOAA.xml file, which is included in Appendix 4. Each of the following grid resolutions has its own CUBE parameter set: 0.5m, 1m, 2m, 4m, 8m, 16m, and 32m. Field units shall use the parameter set corresponding to the

appropriate resolution(s) and depth ranges of their survey data as specified in section 5.2.2 of the HSSD. A description of each parameter and its default value and allowable range of values can be found in the header of the

XML file.

Three parameters have been modified from the CARIS default values: Capture Distance Scale, Capture Distance

Minimum, and Horizontal Error Scalar.

The Capture Distance Scale value is a percentage of depth used to limit the radius of influence a sounding may have

on the grid. The system default value is 5.0. However, for all grid resolutions in the NOAA parameters file, the

value has been set to 0.5. Setting the value this low disables the function and forces the Capture Distance Minimum

to be used instead over the range of applicable grid resolutions. This fixes the Capture Distance to the grid resolution.

A value of 0.5 was determined to be low enough for all grid resolutions, since they grow with depth.

The Horizontal Error Scaler value is used to scale the horizontal error of each sounding when used in the radius of

influence computation. It effects the propagated uncertainty of each sounding and how it is combined into each

hypothesis. The system default value is 2.95. However, based on discussions with Dr. Calder, the value has been set

to 1.96, for all grid resolutions in the NOAA parameters file.

The Capture Distance Minimum value is minimum distance that the CUBE algorithm will search for soundings to

contribute to a node. It is used in conjunction with the Capture Distance Scale to limit the radius or influence of a

sounding. The system default value is 0.5. The Capture Distance Minimum is the only parameter that varies between the grid resolutions in the NOAA parameters file.

The minimum capture distance radius is specified in sections 5.2.2.1 and 5.2.2.2 of the HSSD and is limited to

(0.707*grid resolution), or

This value defines the capture distance to ensure that the radius of influence touches the outer corners of the grid

resolution but not farther. With this capture distance, no sounding is ever “lost” to the algorithm, but there is not

an oversampling of data from areas significantly further than the grid resolution. Because all of the soundings are

in close proximity to the node, the grid most accurately depicts the seafloor in that area without losing any soundings.

Uncertainty Weighted Grids

In order to generate uncertainty-weighted BASE surfaces, TPU. TPU accounts for the a priori horizontal and vertical

components of uncertainty associated with each

sounding measurement. TPU is formulated from the summation of the modeled uncertainties for all sub-systems

included in the overall hydrographic survey system (e.g., water levels, tide zoning, attitude sensor error, navigation

sensor horizontal position error, sound velocity profile error, sonar bottom detection method, etc.). The sources of

uncertainty values include (or may be combination of) manufacturer specifications, theoretical values, and empirical observations from the field. These values are entered into the HVF.

The uncertainty values described in the appendix are provided as guidance for use in standard NOAA hydrographic surveys. These values do not cover the breadth of operations encountered by all field parties, nor do

they cover the range of equipment configurations possible for any particular vessel. As such, these values should

serve a starting point in developing a vessel’s error model. Any deviation from the attached values should be completely described in the applicable Descriptive Reports and DAPR.

In general, soundings (observation points) do not coincide with grid nodes (BASE surface estimation points).

To

account for this, the vertical component of a sounding’s TPU is propagated to a grid node according to a power law

that models the increase in uncertainty as a function of three variables: distance between sounding and node, the

sounding’s horizontal component of TPU, and grid node resolution. The amount of weight an observation exerts

on a given BASE estimation point is inversely proportional to the propagated vertical uncertainty of the observation.

Where V and H are the vertical and horizontal components of TPU (resp.), SH is a scale factor representing the

worst case error that horizontal TPU can contribute, xi and nj are the location of the sounding and estimation node (resp.), x and y are the two-dimensional spacing of grid nodes, and the exponent is a heuristic to control

overall growth of propagated uncertainty, P . The HIPS BASE surface algorithm uses a value of 1.0 (HIPS has already scaled H by 1.96, for a 95% confidence interval) and an value of 2.0. Theoretically, every sounding can affect every node in a BASE surface encompassing a survey area. For computational efficiency, HIPS limits a sounding's radius of influence on surrounding nodes through the following "spreading conditions." (1) At a minimum, each sounding affects all nodes within a radius of 0.707 times the grid resolution of its position; i.e., within half the distance of the diagonal on a regular (square) grid. Hence, a given sounding will affect at least two to four nodes, depending on where it is situated with respect to the nodes. (2) Each sounding will propagate at most a distance determined by a user-specified threshold of propagated vertical uncertainty. The uncertainty threshold is expressed in HIPS according to an IHO sounding error model (see Figure 4.2); that is, an estimate of all constant errors (a) and depth-dependent errors (b times d) are summed in quadrature as shown in OCS requirements for the accuracy of measured depths, as set forth in the HSSD, are adapted from IHO S-44, Standards for Hydrographic Surveys, 5th Edition, which defines Special Order ($a=0.25$ meters, $b=0.0075$), Order 1 ($a=0.5$ meters, $b=0.013$ or 1.3% of depth), and Order 2 ($a=1.0$ meters, $b=0.023$ or 2.3% of depth) standards. OCS specifies that the total sounding error in a measured depth at the 95 percent confidence level, after systematic and system specific errors have been removed, shall not exceed the IHO Order 1 standard in depths up to 100 meters and shall not exceed the IHO Order 2 standard in deeper waters.

Other BASE Weighting Methods in HIPS

CARIS HIPS allows BASE surfaces to be generated using either swath-angle weighting, uncertainty weighting, or CUBE discussed in the previous section. Swath-angle weighted BASE surface nodes do not incorporate TPU and, hence, node "uncertainty" is not available therein. Unless specifically stated to the contrary, use of the term "BASE surface" in conjunction with OCS hydrographic surveys refers to those surfaces generated using the uncertainty weighting method or CUBE.

BASE Node Attributes

The depth at a given BASE surface grid node, n , is the mean depth (weighted by propagated depth uncertainty) of the set of N soundings whose domain, D_i , contains n . Likewise, the uncertainty at a given node is the mean uncertainty (weighted by propagated depth uncertainty) of all the soundings contained in set N . See Figure 4.4

Note that the depth at grid node n is the weighted mean of soundings 1, 2, and 3. Sounding 4 is not included

because its radius of influence does not encompass grid node n.

In addition to depth and uncertainty, users can include five additional attributes in the BASE surface nodal data.

The definitions of the seven nodal attributes are summarized below. Note that all node statistics are computed

from the set of surrounding soundings whose propagated vertical uncertainty passes a user-supplied threshold

(IHO Order):

- Depth - weighted-mean depth of soundings that contribute to a node; weighting is inversely proportional to the propagated vertical uncertainty of the soundings.
- Uncertainty - weighted-mean vertical component of TPU (see section 4.2.3.8) of soundings that contribute to a node; weighting is inversely proportional to the propagated vertical uncertainty of the soundings.
- Density - number of soundings that contribute to a node.
- Std_Dev - sample standard deviation (not weighted) of soundings that contribute to a node; multiply Std_Dev by 1.96 to obtain the 95% confidence interval.
- Shoal - shoalest sounding from the set of soundings that contribute to a node.
- Mean - sample mean of the set of soundings that contribute to a node.
- Deep - deepest sounding from the set of soundings that contribute to a node.

B.2.1.4.3 Methods Used to Derive Final Depths

<i>Methods Used</i>	Gridding Parameters
	Surface Computation Algorithms
<i>Description</i>	CUBE Algorithm used, gridding parameter per FPM guidance.

B.2.2 Imagery

B.2.2.1 Side Scan Sonar

Imagery Object Detection

Imagery data are acquired and processed with the purpose of detecting objects that may be of navigational significance. This determination is typically based on contact type, position, and height above the sea floor estimated from the item's acoustic shadow on the SSS record. Imagery data acquired for OCS hydrographic surveys

are geographically referenced; thus, a position can be determined for each contact identified. The accuracy of this

position will vary depending on whether the sonar was towed or hull-mounted, but either method should be sufficient to locate the item for further investigation. If a contact is determined to be significant, a "development"

should be conducted to determine the item's least depth and a more accurate position for charting.

Daily Batch Processing

Several processing tasks need to be performed on “raw” imagery data (i.e., unaltered data in the format generated by the acquisition software) before any detailed analysis and evaluation can occur. Some of these daily tasks are interdependent, and the specific sequence is critical. The recommended ordering of daily batch processing tasks is as follows:

1. Conversion
2. Filter, if applicable
3. Recompute Towfish Navigation
4. Slant Range Correction

Most of the tasks above can be semi-automated in HIPS/SIPS using the “Batch Processor” tool. Data format determines how specific processing actions need to be configured; as such, a separate Batch Processing File (.hbp) is needed for each raw data format type.



Figure 16: Side Scan Sonar

B.2.2.2 Phase Measuring Bathymetric Sonar

Phase measuring bathymetric sonar imagery was not processed.

B.2.2.3 Specific Data Processing Methods

B.2.2.3.1 Methods Used to Maintain Data Integrity

Imagery data should be reviewed twice using CARIS SIPS Side Scan Editor. The initial review process is referred to as “scanning” the data. The second review is performed by a different person and is called “check scanning.” The initial reviewer should identify any object that warrants further investigation, often referred to as a “significant contact”, and record these items into the digital data. The second review serves as a quality control, and should add any significant contacts that were overlooked during the initial check.

B.2.2.3.2 Methods Used to Achieve Object Detection and Accuracy Requirements

Imagery data are acquired and processed with the purpose of detecting objects that may be of navigational significance. This determination is typically based on contact type, position, and height above the sea floor estimated from the item’s acoustic shadow on the SSS record. Imagery data acquired for OCS hydrographic surveys are geographically referenced; thus, a position can be determined for each contact identified. The accuracy of this position will vary depending on whether the sonar was towed or hull-mounted, but either method should be sufficient to locate the item for further investigation. If a contact is determined to be significant, a “development” should be conducted to determine the item’s least depth and a more accurate position for charting.

B.2.2.3.3 Methods Used to Verify Swath Coverage

A survey-wide side scan mosaic should be created and maintained during Daily Batch Processing to evaluate data coverage, identify any gross systematic errors, and plan future data acquisition. Note: If a 200% side scan survey is being conducted, a separate mosaic should be created to demonstrate coverage for each hundred percent. In addition to planning future SSS acquisition, the first 100% mosaic can be used to delineate areas of high contact density where complete MBES coverage is more appropriate than 200% SSS. The hydrographer is reminded that AWOIS radii that extend beyond the basic survey limits must be entirely covered with 200% side scan, complete or object detection multibeam, or a combination thereof to be disproved by sonar data. These radii should be considered when evaluating survey coverage. When creating a mosaic, the hydrographer will be prompted for several pieces of information. In accordance with section 6.2.1 of the HSSD, resolution shall be 1m by 1m or less. Maximum across-track and altitude ratios can be used to systematically remove areas of poor quality data from the mosaic, such as when outer edges are affected by

thermocline. Note: These features will not actually reject the imagery data, but they will remove portions indicated

for all lines in the mosaic.

Options such as interpolation and shine-thru may be used at the hydrographer's discretion. These features may

enhance the overall mosaic and can be desirable for creating constituent products.

B.2.2.3.4 Criteria Used for Contact Selection

SIPS provides several tools to assist in

determining if a contact is significant. Two of the most frequently used are "Measure Shadow" and "Measure Distance."

"Measure Shadow" can be used to determine the height of an object by measuring its acoustic shadow and calculating the object's approximate elevation off the seafloor. This tool can only be used when viewing data in slant

range corrected mode. "Measure Distance" is used to measure the distance between two points. This tool is helpful

in determining the overall size of contacts, which may determine significance. For example, a very large item, even

if it does not protrude significantly from the seafloor, may be listed in the AWOIS database and should therefore

be investigated. The Measure Distance tool can be used when viewing both "raw" (i.e., not slant range corrected)

and slant range corrected data.

All significant contacts should be recorded in the digital data by creating a contact in SIPS. (Refer to the CARIS

HIPS and SIPS Users Guide for detailed information on how to create a contact.) The general OCS practice for

determining significance of an imagery contact is stated in the HSSD.

The hydrographer must always consider the location of a contact when determining significance. For example, in

a major channel where vessels transit with minimal underkeel clearance, a contact less than one meter high could

be significant.

When a contact is recorded in SIPS, the item is geo-coded and attributes are attached to it in the Side Scan Editor.

Each contact should be attributed as thoroughly as possible. A contact file is created for each survey line and is

stored in the line folder within the Project directory structure.

B.2.2.3.5 Compression Methods Used for Reviewing Imagery

No compression methods were used for reviewing imagery.

B.2.3 Sound Speed

B.2.3.1 Sound Speed Profiles

Correcting sonar data for the speed of sound (through water) actually refers to performing a refraction correction based on a sound speed profile of the water column. Variations in the speed of sound (primarily due to water temperature variations, or thermocline) result in refraction (bending) of sonar beams. The speed of sound through water will decrease as water temperature lowers, causing a sonar beam to bend downward and creating depth and position errors in any measurement calculated based on travel time and an assumed linear travel path of the sonar beam. Figure 4.7 illustrates the effect of refraction. The sound wave striking the thermocline at point B slows down, while point A on the same sound wave continues at the original speed until it strikes the thermocline at C. As a result, the sonar beam bends downward.

B.2.3.1.1 Specific Data Processing Methods

B.2.3.1.1.1 Caris SVP File Concatenation Methods

Through Pydro Velocipy software, concatenated in a project master file.



Figure 17: Odom Digibar

B.2.3.2 Surface Sound Speed

The DigibarPro Profiling Sound Velocimeter is a portable, user-deployed instrument. The DigibarPro system includes a high frequency “sing-around” transducer and a reflector precisely spaced to facilitate measuring the speed of sound in water by continuously transmitting and receiving a signal across a known separation distance.

The sing-around frequency and associated depth information are recorded at a rate of 10 samples per second.

In many OCS applications, DigibarPro systems have been mounted to or near a MBES transducer to directly measure sound speed at the sonar face.

Recorded DigibarPro sound speed profiles can be uploaded to a PC and processed using NOAA’s Velocipy software.



Figure 18: Odom Digibar

B.2.4 Horizontal and Vertical Control

B.2.4.1 Horizontal Control

Horizontal control data were not processed.

B.2.4.2 Vertical Control

Water Level Data Retrieval

Typically, predicted tides or preliminary water level data are applied to soundings during initial post-processing.

As verified or final water level data become available, the best quality data should be applied to bathymetry. Field units can download six-minute preliminary water level data directly from the Products > Tides section of the COOPS website <http://www.tidesandcurrents.noaa.gov> within hours of data acquisition. Verified water level data should be available from the CO-OPS website within seven days if the station has been placed on the Hydro Hot List.

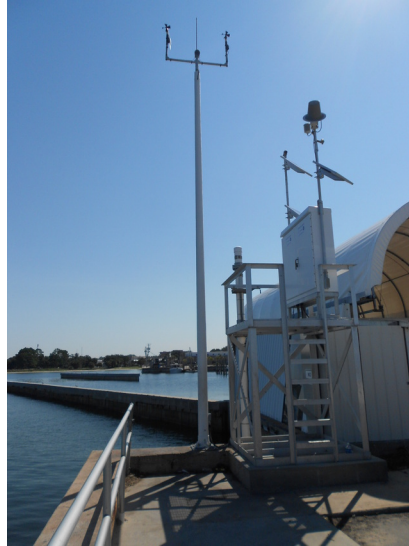

Figure 19: NOAA Tide Gauge #8729108

B.2.5 Feature Verification

Feature verification of assigned features were done through bathymetric investigations with MBES or VBES, or visually when these investigations were not possible or unnecessary.

Figure 20: N/A

B.2.6 Backscatter

Backscatter data were not processed.

B.2.7 Other

No additional data were processed.

B.3 Quality Management

Quality management is done on a daily basis. The team follows strict data acquisition and processing routines enunciated by the FPM and HSSD to ensure highest data quality.

B.4 Uncertainty and Error Management

TPU accounts for the a priori horizontal and vertical components of uncertainty associated with each sounding measurement. TPU is formulated from the summation of the modeled uncertainties for all sub-systems

included in the overall hydrographic survey system (e.g., water levels, tide zoning, attitude sensor error, navigation sensor horizontal position error, sound velocity profile error, sonar bottom detection method, etc.). The sources of uncertainty values include (or may be combination of) manufacturer specifications, theoretical values, and empirical observations from the field. These values are entered into the HVF.

B.4.1 Total Propagated Uncertainty (TPU)

B.4.1.1 TPU Calculation Methods

Prior to data processing, vessel offsets and total propagated uncertainty values based on uncertainty estimates for survey equipment should have been entered into the corresponding HVF .

For the most part, uncertainty estimates entered into the HVF file are static over a field season or in the absence of

changes to the vessel configuration. Some HVF uncertainty estimate values may need to be adjusted on a case-by-case

basis to account for any un-modeled uncertainty in a given component of the sounding. For example, in areas with strong currents, uncertainty in vessel speed can be adjusted in the sensor TPU section of the HVF to compensate for appreciable differences between speed-over-ground and speed-through-water. Another critical

example of TPU values that may need to be updated in the CARIS HVF is depth uncertainty introduced by heave

in singlebeam data acquired on vessels without an attitude sensor. Survey days with substantial heave introduce a

larger depth uncertainty than calm days, and require a larger TPU value in the heave section of the HVF. An estimation of uncertainty introduced by heave can be calculated by multiplying the heave amplitude (1/2 the wave

height) by 0.707. (This formula is equal to 1 sigma of a sinusoidal wave).

Most of the uncertainty estimates that are entered into a CARIS HVF are straightforward and are based on direct

measurement techniques or manufacturer provided information. The estimation of the uncertainty value associated

with MRU alignment is an exception. There is no direct method to measure or estimate MRU alignment uncertainty.

One method to estimate these values is to calculate the standard deviation of a large sample of angular bias values

resolved with a patch test. The sample size can be created either by a number of people resolving the angular biases

or a couple of people resolving the values numerous times. Angular bias values resolved in a patch test are actually

a measurement of the angular bias that exists between the transducer reference frame and the MRU reference frame. Therefore, any uncertainty values derived from the patch test angular biases are based on the same

relationship. As it is the angle between the MRU and the transducer that we are measuring, rather than the absolute alignments of both the MRU and the transducer to a vessel reference frame, we can assign this uncertainty to either the MRU alignment or the transducer alignment. CARIS expects this value to be entered into the MRU alignment uncertainty field.

Note: All changes made to HVFs used to process OCS hydrographic survey data shall be approved by the field

unit's Chief-of-Party and completely described in the Descriptive Report. Provided the TPU sensor values in the

HVF do not require modification as noted above, TPU computation for specific survey lines is completed by selecting a set of survey lines and choosing the Compute TPU process in HIPS. Once the process has been selected,

uncertainty values that change on a survey-by-survey basis, such as tide and sound speed, are entered into the Compute TPU dialog box (see below regarding Tide zoning uncertainty values for TCARI tides).

CARIS allows for only one sound speed and one tide value to be entered per survey area, on a survey-wide basis

(at BASE surface creation) in the Compute TPU dialog box. HSTP is working with CARIS to adapt a statistical

approach which will allow for multiple values per survey.

B.4.1.2 Source of TPU Values

Project Instructions

B.4.1.3 TPU Values

<i>Vessel</i>	S3004 and S3001			
<i>Echosounder</i>	Odom CV200 100 kilohertz			
<i>TPU Standard Deviation Values</i>	<i>Motion</i>	<i>Gyro</i>	0.02 degrees	
		<i>Heave</i>	5 % Amplitude	
			0.05 meters	
		<i>Pitch</i>	0.02 degrees	
	<i>Roll</i>	0.02 degrees		
	<i>Navigation Position</i>	1 meters		
	<i>Timing</i>	<i>Transducer</i>	0.005 seconds	
		<i>Navigation</i>	0.005 seconds	
		<i>Gyro</i>	0.005 seconds	
		<i>Heave</i>	0.005 seconds	
		<i>Pitch</i>	0.005 seconds	
<i>Roll</i>		0.01 seconds		

<i>Offsets</i>	<i>x</i>	0 meters
	<i>y</i>	0 meters
	<i>z</i>	0 meters
<i>MRU Alignment</i>	<i>Gyro</i>	0.5 degrees
	<i>Pitch</i>	0.5 degrees
	<i>Roll</i>	0.5 degrees
<i>Vessel</i>	<i>Speed</i>	0 meters/second
	<i>Loading</i>	0.01 meters
	<i>Draft</i>	0.01 meters
	<i>Delta Draft</i>	0.081 meters

B.4.2 Deviations

There were no deviations from the requirement to compute total propagated uncertainty.

Additional Discussion

Delta Draft TPU adjusted after 2014 Settlement & Squat procedure (MBES surface difference method)

C Corrections To Echo Soundings

C.1 Vessel Offsets and Layback

C.1.1 Vessel Offsets

C.1.1.1 Description of Correctors

S3004 and S3001 Offsets

C.1.1.2 Methods and Procedures

Total Station Survey, NGS offsets survey, June 3rd 2009 (S3004), and Buchanan and Harper, surveyors, April 10, 2013 (S3001)

C.1.1.3 Vessel Offset Correctors

<i>Vessel</i>	S3004 and S3001		
<i>Echosounder</i>	Odom CV200 100 kilohertz		
<i>Date</i>	2009-06-03		
<i>Offsets</i>	<i>MRU to Transducer</i>	<i>x</i>	0 meters
		<i>y</i>	0 meters
		<i>z</i>	0 meters
		<i>x2</i>	0 meters
		<i>y2</i>	0 meters
		<i>z2</i>	0 meters
	<i>Nav to Transducer</i>	<i>x</i>	0 meters
		<i>y</i>	0 meters
		<i>z</i>	0 meters
		<i>x2</i>	0 meters
		<i>y2</i>	0 meters
		<i>z2</i>	0 meters
	<i>Transducer Roll</i>	<i>Roll</i>	0 degrees
		<i>Roll2</i>	0 radians

C.1.2 Layback

Layback correctors were not applied.

C.2 Static and Dynamic Draft

C.2.1 Static Draft

C.2.1.1 Description of Correctors

Static draft was calculated by using the WL (waterline) to RP (reference point) and Transducer head to RP offsets.

C.2.1.2 Methods and Procedures

Boat offset values from Buchanan and Harper, professional surveyors.

C.2.2 Dynamic Draft

C.2.2.1 Description of Correctors

Dynamic draft was measured on May 10th 2012 (S3004, before the vessel was retired), May 22nd, 2013 (S3001), April 21st, 2014 (S3001)

C.2.2.2 Methods and Procedures

MBES surface comparison method

C.2.2.3 Dynamic Draft Correctors

<i>Vessel</i>	S3004				
<i>Date</i>	2012-05-10				
<i>Dynamic Draft Table</i>	<i>Speed</i>	1.05 meters/second	2.3 meters/second	3.17 meters/second	3.77 meters/second
	<i>Draft</i>	0 meters	0.028 meters	0.039 meters	0.031 meters
<i>Vessel</i>	S3001				
<i>Date</i>	2013-10-31				
<i>Dynamic Draft Table</i>	<i>Speed</i>	1.23 meters/second	2.74 meters/second	3.55 meters/second	4.18 meters/second
	<i>Draft</i>	0 meters	-0.006 meters	-0.003 meters	0.029 meters
<i>Vessel</i>	S3001				
<i>Date</i>	2014-05-19				
<i>Dynamic Draft Table</i>	<i>Speed</i>	0.551 meters/second	1.196 meters/second	2.8 meters/second	4.107 meters/second
	<i>Draft</i>	0 meters	-0.004 meters	-0.016 meters	0.024 meters

C.3 System Alignment

C.3.1 Description of Correctors

MBES calibration

C.3.2 Methods and Procedures

patch test method

C.3.3 System Alignment Correctors

<i>Vessel</i>	S3004
<i>Echosounder</i>	Reson 8125 455 kilohertz
<i>Date</i>	2012-02-21

<i>Patch Test Values</i>	<i>Navigation Time Correction</i>	0 seconds
	<i>Pitch</i>	5.38 degrees
	<i>Roll</i>	0.656 degrees
	<i>Yaw</i>	-1.75 degrees
	<i>Pitch Time Correction</i>	0 seconds
	<i>Roll Time Correction</i>	0 seconds
	<i>Yaw Time Correction</i>	0 seconds
	<i>Heave Time Correction</i>	0 seconds
<i>Vessel</i>	S3001	
<i>Echosounder</i>	Reson 8125 455 kilohertz	
<i>Date</i>	2013-03-19	
<i>Patch Test Values</i>	<i>Navigation Time Correction</i>	0 seconds
	<i>Pitch</i>	3.8 degrees
	<i>Roll</i>	1.47 degrees
	<i>Yaw</i>	1.58 degrees
	<i>Pitch Time Correction</i>	0 seconds
	<i>Roll Time Correction</i>	0 seconds
	<i>Yaw Time Correction</i>	0 seconds
	<i>Heave Time Correction</i>	0 seconds
<i>Vessel</i>	S3001	
<i>Echosounder</i>	Reson 8125 455 kilohertz	
<i>Date</i>	2013-08-21	
<i>Patch Test Values</i>	<i>Navigation Time Correction</i>	0 seconds
	<i>Pitch</i>	1.94 degrees
	<i>Roll</i>	1.84 degrees
	<i>Yaw</i>	0.99 degrees
	<i>Pitch Time Correction</i>	0 seconds
	<i>Roll Time Correction</i>	0 seconds
	<i>Yaw Time Correction</i>	0 seconds
	<i>Heave Time Correction</i>	0 seconds
<i>Vessel</i>	S3001	
<i>Echosounder</i>	Reson 8125 455 kilohertz	
<i>Date</i>	2014-04-10	

<i>Patch Test Values</i>	<i>Navigation Time Correction</i>	0 seconds
	<i>Pitch</i>	1.180 degrees
	<i>Roll</i>	1.586 degrees
	<i>Yaw</i>	0.880 degrees
	<i>Pitch Time Correction</i>	0 seconds
	<i>Roll Time Correction</i>	0 seconds
	<i>Yaw Time Correction</i>	0 seconds
	<i>Heave Time Correction</i>	0 seconds

C.4 Positioning and Attitude

C.4.1 Description of Correctors

Applanix POS/MV positioning and attitude data correctors were recorded concurrently to sounding data.

C.4.2 Methods and Procedures

True Heave was applied to the data during post processing.

C.5 Tides and Water Levels

C.5.1 Description of Correctors

Discrete tide zoning were used as water level correctors. MLLW was used as vertical Datum for all bathymetric data.

C.5.2 Methods and Procedures

Unique tide gauge assigned and used was #8729108, Panama City.

C.6 Sound Speed

C.6.1 Sound Speed Profiles

C.6.1.1 Description of Correctors

Daily sound speed profiles were done for mainscheme data acquisition. During MBES investigations, profiles were done every 4 hours maximum.

C.6.1.2 Methods and Procedures

Digibar pro and Velocipy are used as post processing softwares.

C.6.2 Surface Sound Speed

C.6.2.1 Description of Correctors

Surface sound speed profiles were acquired concurrently to MBES data acquisition.

C.6.2.2 Methods and Procedures

Direct input in MBES TPU.

