

U.S. DEPARTMENT OF COMMERCE
NATIONAL OCEANIC AND ATMOSPHERIC ADMINISTRATION
NATIONAL OCEAN SERVICE

Data Acquisition & Processing Report

Type of Survey Hydrographic

Project No. 2012 Field Season

Registry No. _____

LOCALITY

State Washington and Alaska

General Locality _____

CDR James M. Crocker, NOAA
CHIEF OF PARTY

LIBRARY & ARCHIVES

DATE 12/27/12



Fairweather 2012
Data Acquisition & Processing Report



A. INTRODUCTION..... A-1

B. EQUIPMENT B-1

1.0 Hardware..... B-1

1.1 Hardware Systems Inventory B-1

1.2 Echo Sounding Equipment..... B-1

 1.2.1 Reson 7111 Multibeam Echosounder (MBES) B-1

 1.2.2 Reson 8160 Multibeam Echosounder (MBES) B-2

 1.2.3 Reson 7125 SV Multibeam Echosounder (MBES) B-3

 1.2.4 Klein 5000 Side Scan Sonar (SSS)..... B-4

1.3 Manual Sounding Equipment..... B-5

 1.3.1 Lead Lines B-5

1.4 Positioning, Heading, and Attitude Equipment..... B-6

 1.4.1 Applanix Positioning and Orientation System for Marine Vehicles (POS MV). B-6

 1.4.2 POS MV GAMS Calibration..... B-6

 1.4.3 DGPS Receivers B-7

 1.4.4 Trimble Backpack..... B-8

 1.4.5 Hand-held Laser B-8

1.5 Sound Speed Equipment B-9

 1.5.1 Sound Speed Profiles..... B-9

 1.5.1.1 SBE 19plus SEACAT Profiler..... B-9

 1.5.1.2 Moving Vessel Profiler 200 B-10

 1.5.2 Surface Sound Speed..... B-11

 1.5.2.1 Reson Sound Velocity Probe (SVP 70) B-11

 1.5.2.2 Reson Sound Velocity Probe (SVP 71) B-12

1.6 Vertical Control Equipment B-13

 1.6.1 Water Level Gauges B-13

 1.6.2 Leveling Equipment B-13

1.7 Horizontal Control Equipment..... B-14

2.0 Software..... B-14

2.1 Software Systems Inventory..... B-14

2.2 Data Acquisition Software B-15

 2.2.1 Hypack® Hysweep..... B-15

 2.2.2 CARIS Notebook..... B-15

 2.2.3 Klein SonarPro B-16

2.3..... B-16

 2.3.1 Applanix POSView B-16

2.4 Data Processing Software..... B-16

 2.4.1 CARIS B-16

 2.4.2 Fledermaus™..... B-17

Process Owner: Survey Updated: 12/5/2012	Approval: CO <i>Fairweather</i> Approval Date: 2012	
--	---	--

2.4.3	Geocoder.....	B-17
2.4.4	Applanix POSPac MMS and POSGNSS	B-17
2.4.5	Velocipy.....	B-17
2.4.6	Pydro.....	B-17
3.0	Vessels.....	B-18
3.1	Vessel Inventory.....	B-18
4.0	Data Acquisition	B-18
4.1	Horizontal Control.....	B-18
4.2	Multibeam Echosounder Acquisition and Monitoring Procedures	B-18
4.3	Shoreline/Feature Verification	B-19
4.4	Bottom Samples	B-20
4.5	Sound Speed.....	B-20
C.	QUALITY CONTROL.....	C-20
1.0	Uncertainty Modeling.....	C-21
2.0	Data Processing.....	C-21
2.1	Multibeam Echosounder Data Processing.....	C-21
2.2	Side Scan Sonar Data Processing.....	C-23
2.3	Shoreline/Feature Data Processing.....	C-24
3.0	Data Review.....	C-25
D.	CORRECTIONS TO ECHO SOUNDINGS	D-25
1.0	Vessel HVFs.....	D-25
2.0	Vessel Offsets.....	D-25
3.0	Static and Dynamic Draft	D-27
4.0	Patch Tests.....	D-28
5.0	Attitude and Kinematic Data.....	D-28
5.1	TrueHeave™	D-29
5.2	Post Processed Kinematic Data.....	D-29
6.0	Sound Speed	D-30
7.0	Water Level.....	D-30

APPENDICES

Appendix I System Tracking

Appendix II Vessel Reports, Offsets, and Diagrams

Appendix III Total Propagated Uncertainty



Fairweather 2012
Data Acquisition & Processing Report



A. INTRODUCTION

This Data Acquisition and Processing Report outlines the acquisition and processing procedures used for Hydrographic projects surveyed in 2012 by NOAA Ship *Fairweather*. Survey specific details will be listed in Descriptive Reports as needed. Unless otherwise noted, the acquisition and processing procedures used and deliverables produced are in accordance with the NOAA *Hydrographic Survey Specifications and Deliverables Manual (HSSD) April 2012*, the *Field Procedures Manual (FPM), May 2012*, and all active Hydrographic Surveys Technical Directives (HTD).

Any additions and changes to the following will be included with the individual Descriptive Reports or by submission of an addendum.



B. EQUIPMENT

Detailed descriptions of the equipment and systems, including hardware and software, used for bathymetric data acquisition, horizontal and vertical control operations, shoreline acquisition, and processing are listed below.

1.0 Hardware

The hardware listed in this section is used throughout the 2012 field season.

1.1 Hardware Systems Inventory

Detailed hardware information, including installation dates and serial numbers, is included in Appendix I of this report. Manufacturer's product specifications are maintained with reference documentation on board *Fairweather*.

1.2 Echo Sounding Equipment

Timing delays, ranging from 1 – 20 seconds in duration, have been identified in all *Fairweather* ship multibeam echosounder data following March 2012. The timing issues appear to be related to deviations in the Hypack computer clock being utilized to timestamp the multibeam data instead of the POS MV. The exact causes of the timing offsets remain unresolved to date. Additional entries have been made to the corresponding CARIS Hydrographic Vessel Files (HVF's) to mitigate the effects of the varying time delay for the Reson 7111 and 8160 data.

1.2.1 Reson 7111 Multibeam Echosounder (MBES)

Fairweather is equipped with a Reson 7111 MBES. The system was upgraded from a Reson 8111 in October 2009, which involved replacing the dry end transceiver and processor units but leaving the wet end hull-mounted projector and receiver intact. The Reson 7111 is a 100 kHz multibeam system with swath coverage of 150°. The swath is made up of 301 discrete equidistant beams with an along-track and across-track beamwidth of 0.5°. It has a specified depth range of 3 to 1200 meters, though the typical operational depth range of the Reson 7111 on *Fairweather* is 20 to 300 meters. No calibration information was provided by the manufacturer for the system. However, since there are a limited number of systems in the world used for hydrography, we have worked with RESON and INFREMER regarding improvement with the sonar bottom detection algorithms. Engineering quality receiver and transceiver boards were still in use during the 2012 field season until the new production level boards were installed during drydock in November 2012. No failures were experienced while operating under the engineering boards although spares were carried onboard.

The Reson 7111 is hull-mounted within a reinforced projection that extends 27 inches below the keel. It is located 39.5" starboard of the centerline at approximately frame 29 (see Figure 1 & Figure 2).

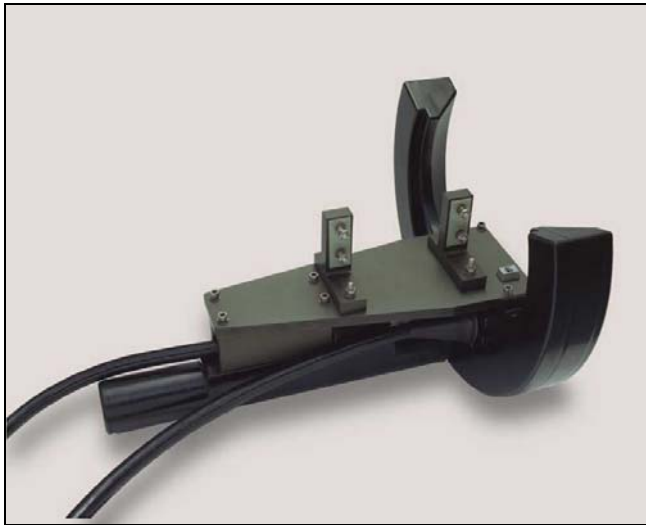

Figure 1: RESON SeaBat 7111 MBES



Figure 2: 7111 Installed on *Fairweather*

The unresolved timing offsets with the ship multibeam systems, described above, range less with the 7111 than with the Reson 8160. With the offsets entered into the vessel HVF, any remaining data artifacts are well within allowable vertical and horizontal uncertainties for the corresponding depth ranges and are recommended for charting purposes.

Unusually high uncertainty values were experienced in the outer 6 degrees of Reson 7111 data on either side of the swath this field season. To avoid exceeding IHO Order 1 specifications for depths shallower than 100 meters, these outer beams were rejected in post processing for all surveys. Multibeam line spacing was tightened in these areas during acquisition to prevent the creation of holidays in the data.

1.2.2 Reson 8160 Multibeam Echosounder (MBES)

Fairweather is also equipped with a Reson SeaBat 8160 MBES with the snippet option. The Reson 8160 is a 50 kHz multibeam system with swath coverage of greater than 4x water depth. Each swath is made up of 126 discrete beams with an along-track and across-track beamwidth of 1.5°. Though the Reson 8160 on *Fairweather* has a specified depth range of 10 to 3000 meters, the typical operational depth range is 300 to 1000 meters. No calibration information was provided by the manufacturer of the system.

The 8160 is hull-mounted within a reinforced projection that extends 13.6 inches below the keel. It is located 54 inches port of the centerline at approximately frame 29 (see Figure 3 & Figure 4).

Aside from the known data quality issues associated with the 8160, the unresolved timing offsets mentioned above ranged much larger with the 8160 than with the 7111 and data collected by the 8160 is not recommended for charting at this time.



Figure 3: Reson SeaBat 8160 MBES



Figure 4: 8160 Installed on *Fairweather*

1.2.3 Reson 7125 SV Multibeam Echosounder (MBES)

Survey launches 2805 and 2808 are each equipped with a dual frequency Reson 7125 SV MBES. The Reson 7125 SV has both a low frequency (200kHz) and high frequency (400kHz) transmit array with a swath coverage of 128°. The swath is made up of 256 discrete beams for 200 kHz and both 256 or 512 discrete beams for 400 kHz. The typical operational depth ranges for the Reson 7125 SV operating at 200kHz is 3 to 400 meters and 3 to 100 meters operating with the 400kHz system. Each system is hull mounted along the centerline and includes a single topside unit (see Figure 5 & Figure 6). No calibration information was provided by the manufacturer for the systems; however, the unit installed on 2805 was tank calibrated for backscatter at the University of New Hampshire (UNH) during the winter of 2011. Preliminary calibration reports are forthcoming. Research is ongoing for 7125 SV backscatter calibration.



Figure 5: Reson 7125 SV topside processor



Figure 6: Reson 7125 SV transducer arrays

1.2.4 Klein 5000 Side Scan Sonar (SSS)

Fairweather utilizes both lightweight and heavyweight Klein Series 5000 sonar systems in addition to a Klein Series 5410 system operated without the bathymetry option. Each system is comprised of a side scan sonar towfish, Transceiver and Processing Unit (TPU), specialized tow and data cables, and a Windows- based acquisition computer. These systems operate at a nominal frequency of 500 kHz (455 kHz actual) and are rated to 200 meters depth. Acquisition is conducted with Klein's SonarPro™ software and files are logged in SDF format. Post processing occurs in CARIS SIPS.

The towfish can be used as hull-mounted (Figure 7) or towed (Figure 8) by any of *Fairweather's* launches or else towed from *Fairweather* (Figure 9). In the hull-mounted configuration, the towfish is bolted to a sled on the bottom of the launch. The sled is situated to port of the keel and is approximately centered fore and aft. In the launch towed configuration, the lightweight Klein 5000 is towed by a CSW-6 portable electric winch on 0.257 inch diameter cable. In the towed configuration on *Fairweather*, the towfish can be fitted with a K-wing depressor and affixed to armored coaxial cable for deployment from *Fairweather's* A-frame. The amount of tow cable being used is automatically entered into SonarPro™ for towfish layback calculation for the *Fairweather* system and manually entered by the operator for the launch towed system. In a towed configuration a side scan position certification check will be conducted and documented prior to data collection and system utilization. Offsets and values used in the ship Klein 5000 HVF are included in the Offset spreadsheets included in Appendix II.

Dual acquisition of Klein 5000 SSS and Reson 7125 or 7111 MBES data is the standard procedure with all side scan configurations. The launch wiring diagrams are configured for Klein 5000 SSS and multibeam dual acquisition at all times. Additionally, all Reson 7125 MBES data acquired with hull mounted SSS data is filtered down to 45-degrees on either side.



Figure 7: Hull-Mounted Klein 5000 Side Scan Sonar on *Fairweather* Launch with TPU



Figure 8: Launch-Towed Klein 5000 Side Scan Sonar



Figure 9: Towed Klein 5000 Side Scan Sonar on Fairweather

1.3 Manual Sounding Equipment

1.3.1 Lead Lines

Vessels are equipped with a lead line when appropriate. Lead lines are used for depth measurements near shore over submerged shoals and for echosounder depth comparisons.

Lead lines were created, measured and calibrated according to Section 1.5.3 of the *FPM*. Calibration was performed by *Fairweather* personnel on March 9, 2012, and documentation is maintained onboard.

1.4 Positioning, Heading, and Attitude Equipment

1.4.1 Applanix Positioning and Orientation System for Marine Vehicles (POS MV)

Fairweather and her launches are each equipped with a POS MV 320 V4, configured with TrueHeave™. The POS MV calculates position, heading, attitude, and vertical displacement (heave) of a vessel. It consists of a rack mounted POS Computer System (PCS), a strap down IMU-200 Inertial Measurement Unit (IMU), and two GNSS antennas corresponding to GNSS receivers in the PCS. *Fairweather* (S220) and launches 2805 and 2808 are equipped with Zephyr II GNSS antennas. *Fairweather* (S220) and launch 2805 are equipped with BD960 PCS antenna receiver cards, and launch 2808 is equipped with BD950 PCS antenna receiver cards. Both launch PCS units for 2805 and 2808 have also been upgraded for internal logging capabilities to eliminate packet drops across the acquisition network. The port side antenna is designated as the primary receiver, and the starboard side antenna is the secondary receiver for all vessels (see Figure 9). The POS MV firmware versions and the controller software versions that are currently installed are listed in the Hardware Inventory in Appendix I.

For all multibeam systems aboard *Fairweather* and her launches, timing between the sonar swath, position, heading and attitude information was synchronized by utilizing the proprietary UTC string from POS MV. A timing string is sent from the POS MV to the Reson topside unit via serial connection and to the Hypack acquisition computer via Ethernet.

For the launch PCS units with internal logging capabilities, data is logged as small 12 MB files which are concatenated into a single .000 file. Files are concatenated through the NOAA in-house tool “POSConcatenator” created by Grant Froelich of the Pacific Hydrographic Branch.

POS MV controller software was used to monitor position accuracy and quality during data acquisition. This ensured that positioning accuracy requirements are met, as outlined in section 3 of the *HSSD*. The POS MV controller software provides clear visual indications whenever accuracy thresholds are exceeded.

1.4.2 POS MV GAMS Calibration

In the spring of 2012, GNSS Azimuth Measurement System (GAMS) calibrations were performed on each of *Fairweather's* three POS MV units mounted to launches 2805, 2808 (Figure 10), and *Fairweather* (S220). The GAMS calibration procedure was conducted in accordance with instructions in chapter 4 of the *POS MV V4 User Guide*, 2009. Results and calibration reports are maintained with reference documentation aboard *Fairweather*. Actual calibration dates are listed in the Hardware Inventory included in Appendix I.



Figure 10: POS GNSS Antennas

1.4.3 DGPS Receivers

Fairweather is equipped with a commercial grade CSI Wireless MBX-3S DGPS Receiver on *Fairweather* (S220) and Hemisphere GPS MBX-4 DGPS receivers on launches 2805 and 2808 that are used to correct the POS MV GPS positions used during real-time MBES and SSS data acquisition. The DGPS receivers are configured in manual mode to allow reception of only one U.S. Coast Guard (USCG) differential GPS beacon station at a time.

Differential GPS (DGPS) is the primary method of real-time positioning. The individual descriptive reports for each survey list the U.S. Coast Guard beacon sites and frequencies used for differential corrections utilized during hydrographic surveying.

When *Fairweather* operates in remote areas outside of DGPS range, such as during Arctic projects, *Fairweather* and launch 2805 are equipped with POSMV PCS units with integrated DGPS. These units are capable of receiving the satellite based augmentation systems (SBAS) such as WAAS for real-time decimeter position accuracy. Launch 2808 is not equipped with one of these PCS units and runs in course acquisition mode (CA) during real-time data acquisition in these areas. Horizontal position accuracies in CA mode range from 2-3 meters. The individual descriptive reports for each survey will indicate if WAAS correctors were utilized instead of DGPS.

All individual vessel POSMV files from all platforms are post processed unless otherwise noted in respective survey Descriptive Reports and project Horizontal and Vertical Control Reports.

1.4.4 Trimble Backpack

Fairweather uses two GPS Pathfinder® Pro XRS receivers in conjunction with a field computer to acquire detached positions during shoreline verification in the field. Data can also be collected with a handheld TSCe data collector. Field computers currently in use are Panasonic Toughbooks; two CF-30's, one CF-29, one CF-19, and one CF-18's. The receivers have integrated DGPS beacon/satellite differential antennas which allow access to digital real-time sub-meter accuracy solutions. Data quality assurance testing was conducted by *Fairweather* personnel on March 20, 2012. Trimble units (Figure 11) were tested over a published benchmark. Trimble positions matched the published benchmark position within 0.55m. Test results are maintained with reference documentation on board *Fairweather*.



Figure 11: Trimble Backpack Unit

1.4.5 Hand-held Laser

The Impulse Laser Rangefinder (Figure 12) and TruPulse 200 Laser Rangefinder (Figure 13) are used in conjunction with the Trimble Backpack GPS unit to acquire distances and heights during shoreline verification. These data are entered directly into the shoreline acquisition software and annotated on the detached position forms. The Impulse LR and TruPulse 200 Laser Rangefinders do not function properly in low light or in choppy seas when a feature is not distinguishable from surroundings.



Figure 12: IMPULSE LR Laser Rangefinder



Figure 13: TruPulse 200 Laser Rangefinder

Data quality assurance testing was conducted on March 20, 2012 by *Fairweather* personnel. Vertical and horizontal readings were taken with the laser rangefinders and compared to measurements taken with a steel tape. The laser rangefinder was set up on a tripod and a staff of known height was measured at distances of 10, 20, 50, and 100 meters. Three horizontal and three vertical readings were taken at each interval with values only varying within +/- 0.1m. Detailed results of the laser rangefinder accuracy testing are maintained with reference documentation on board *Fairweather*.

1.5 Sound Speed Equipment

1.5.1 Sound Speed Profiles

1.5.1.1 SBE 19plus SEACAT Profiler

Fairweather is equipped with two SBE 19*plus* and two SBE 19*plus*V2 SEACAT sound speed profilers used to acquire conductivity, temperature, and depth (CTD) data in the water column to determine the speed of sound through water. One of the SBE 19*plus* profilers has pressure sensors rated to 1000 meters. The second SBE 19*plus* profiler has a pressure sensor rated to 3,500 meters. The two SBE 19*plus*V2 profilers have pressure sensors and units rated to 600 meters.

The SBE 19*plus* and SBE 19*plus*V2 SEACAT sound speed profilers were calibrated by the manufacturer during the 2011-2012 winter repair period. The current calibration files can be found in Appendix I.

Periodic quality assurance checks include comparison casts between CTD instruments. Data quality assurance (DQA) checks are conducted during each survey leg include comparison casts between two instruments as per section 1.5.2.2.2 of the *FPM* for each survey. Records of the DQA tests performed are kept aboard the ship and are included with the digital Separates II – Sound Speed Data for each survey. To ensure that the CTDs continue to function properly a stringent maintenance schedule is followed using guidelines from the manufacturer's recommendations.

1.5.1.2 Moving Vessel Profiler 200

A Brooke Ocean Technology, Ltd. (BOT) Moving Vessel Profiler 200 (MVP 200) is mounted in the aft starboard corner of the fantail (see Figure 14). The MVP 200 system is a self contained sound speed profiling system capable of sampling water column profiles to 200 meters deep from a vessel moving up to 12 knots. The system is configured with a Single Sensor Free Fall Fish (SSFFF) outfitted with an Applied Microsystems Ltd. Sound Velocity and Pressure Smart Sensor. Deeper profiles can be obtained by reducing the vessel speed. When the vessel is holding station, the system is capable of recording casts over 400m in depth.

The MVP system consists of a winch, cable, fish (the towed unit with the sound velocity sensor), support assembly, and controlling hardware and software. During data acquisition the fish is deployed using the on-deck controller and towed with enough cable out to keep the fish 2-5 m below the water surface. A “messenger” (a short cable-thickening sleeve) is set to allow the system to keep the appropriate amount of cable out and is reset as needed when the ship acquisition speed is altered.

During SVP acquisition, the controlling computer application, BOT MVP with software version 2.401 (1/1/12-5/1/12) or 2.450 (5/15/12- current) is used to control the MVP system and to acquire SVP data. The MVP allows for three acquisition modes: 1) automatic continuous multiple cast freefall casting while at speed, 2) single cast freefall casting while at speed, and 3) single cast winch speed casting while stationary. The user limits the depth to which the fish will fall by setting 1) the depth-off-bottom 2) the maximum depth and 3) maximum cable out. Either single, individually initiated casts can be performed at the discretion of the Hydrographer or the auto deployment function can be enabled and set with varying intervals (every 10 minutes, for example) for deployment.

Fairweather has three Applied Microsystems Ltd. Sound Velocity and Pressure Smart Sensors. The current calibration files can be found in Appendix I.

Periodic quality assurance checks include comparison casts between the MVP and one of the SBE 19*plus* or SBE 19*plusV2* SEACATs. Data quality assurance (DQA) checks include comparison casts among the instruments as per section 1.5.2.2.2 of the *FPM* for each survey. Records of the DQA tests performed are kept aboard the ship and are included with the digital Separates II – Sound Speed Data for each survey.



Figure 14: *Fairweather's* MVP200 sound velocity system

1.5.2 Surface Sound Speed

1.5.2.1 Reson Sound Velocity Probe (SVP 70)

Fairweather is equipped with one Reson SVP 70. The SVP 70 measures the speed of sound near the ship's hull mounted transducers to provide real time surface sound speed (SSP) values. The unit is mounted adjacent to the Reson 8160 as shown in Figure 15.



Figure 15: *Fairweather's* SVP 70 sound speed unit (left) and the 8160

The sound speed is output to the Reson 7111 and Reson 8160's processing units. The transducers require sound velocity information for beam forming. The Reson 7111 and Reson 8160 are not used to acquire data without real time sound speed information.

The unit was installed during the 2009 winter drydock period in Seattle, Washington, at Lake Union Drydock Company. The last calibration of the unit was dated January 4, 2009; and the calibration file can be found in Appendix I with the calibration file for the fleet spare, also listed on *Fairweather's* hardware inventory.

During project OPR-N326-FA-12 in Admiralty Inlet, the outer beams of the Reson 7111 were found to not meet IHO Order 1 specifications. It was believed that the issue was related to how CARIS applied the SSP values to the round faced transducer data. SSP files were deleted from all Reson 7111 CARIS HIPS HDCS processed data collected from May 1st, 2012 – June 29th, 2012. This action greatly improved the visual sound speed artifacts in the outer beams, but did not affect the outer beams still failing IHO Order 1 Uncertainty requirements.

After verifying that CARIS HIPS was correctly applying SSP to the Reson 7111 data, no more SSP files were deleted after June 29th, 2012. While in Bristol Bay working on the Fishpac Project (M-R908-FA-12), it was noticed that the SVP 70 values were no longer agreeing with the MVP sound speed values from the corresponding depth. From July 15th – 21st, 2012, SSP values were entered directly into the Reson 7111 and 8160 from the MVP until *Fairweather* arrived in Dutch Harbor to arrange a hull dive for SVP 70 troubleshooting. The SVP 70 was found to be fouled with marine life on July 21st, 2012 and after cleaning, the unit once again agreed with other sound speed instruments.

1.5.2.2 Reson Sound Velocity Probe (SVP 71)

Survey launches 2805 and 2808 are each equipped with a Reson SVP 71. The SVP 71 measures the speed of sound near the transducer to provide real time surface sound speed values to the Reson 7125's processing unit. The 7125 SV requires surface sound speed information for beam forming due to the flat faced transducer. The units are hull-mounted adjacent to the Reson 7125's transducers as shown in Figure 16.

All of the sensors were initially calibrated by the manufacturer and current calibration files were supplied with the units upon receipt in 2010. The delivery calibration files can be found in Appendix I.



Figure 16: SVP 71 sound speed unit (right) and a Reson 7125

1.6 Vertical Control Equipment

1.6.1 Water Level Gauges

Three (3) Sutron 9210B Portable Tide Gauges were provided to *Fairweather* by the Center for Operational Oceanographic Products and Services (CO-OPS) at the start of the 2012 field season. The gauges are equipped with Paros Scientific Sensors for pressure measurements. The tide gauges are annually tested and inspected by CO-OPS Field Operations Division personnel to ensure that their accuracy and standards are being met. CO-OPS provided documentation for the annual throughput testing conducted on each Portable Tide Gauge during February 2012.

Installation and removal of the water level gauges is the responsibility of *Fairweather* personnel. The CO-OPS-issued Portable Tide Gauges are furnished with necessary accessories; however, *Fairweather* maintains an inventory of tools and equipment necessary to support these gauges.

1.6.2 Leveling Equipment

Fairweather is equipped with four universal automatic levels (two Zeiss NI2 333 and two Leica NA2 100) and graduated metric staffs to assist in leveling tide gauges. Calibration was conducted by Kuker-Ranken Inc. on February 26, 2011 on both Zeiss levels, as the Leica levels

are spares that have never been used they are calibrated bi-annually with their last calibration on February 2, 2010. All calibration paperwork is maintained with reference documentation aboard *Fairweather*.

A Kukkamaki procedure is performed prior to leveling in order to verify the collimation error. Procedures used followed those described in the *User's Guide for the Installation of Bench Marks and Leveling Requirements for Water Level Stations*, October 1987. Kukkamaki procedures were performed on March 2, 2012 for all four levels, and collimation errors were less than 0.05 mm/m. Detailed 2012 results are maintained with reference documentation aboard *Fairweather*.

1.7 Horizontal Control Equipment

Fairweather is equipped with two Trimble NetR9, one Trimble NetR5, and one Ashtech Z-Xtreme dual-frequency GPS base stations used for the positioning of horizontal control marks, tidal benchmarks and aids to navigation. These base stations can be configured for use as a portable DGPS or RTK reference station, or as a static receiver to record observations for use in post processing kinematic (PPK) correctors.

Equipment accuracy testing of the three Trimble GPS units was performed by *Fairweather* personnel at MOC-P in Newport, OR during the week of March 19, 2012 through March 24, 2012. Data logging issues were encountered with the Ashtech Z-Xtreme GPS unit; therefore, it will not be utilized in acquisition for the 2012 field season. The Online Positioning User Service (OPUS) solutions were obtained using data acquired with the Trimble GPS units over a local benchmark and comparing the solutions to each other and to the published data sheet for the geodetic mark used. Data compared well within the accuracy of the published position of the benchmark. The OPUS solutions are maintained with reference documentation aboard *Fairweather*.

When deployed for PPK the base stations log data locally, either to internal or external memory, and the data is downloaded periodically. The data is downloaded either by visiting the site or remotely via Freewave w900 MHz spread spectrum Ethernet radios mounted to *Fairweather* and her launches. Station power needs are supported by batteries and solar panels. All receiver antennas are mounted on a Seco, fixed height GPS tripod when deployed in the field. Horizontal control equipment serial numbers and version installation dates are located in the hardware section of Appendix I.

2.0 Software

2.1 Software Systems Inventory

An extensive software inventory with documentation of the software systems used by *Fairweather* is maintained as a survey *Software Inventory* spreadsheet on board *Fairweather*. This spreadsheet includes specifics such as software applications, versions, and hotfixes that are loaded on specific survey processing computers. Snapshot .pdf files are produced monthly. The pertinent monthly inventories are included with the Supplemental Survey Records for the individual Descriptive Reports.

2.2 Data Acquisition Software

2.2.1 Hypack® Hysweep

Fairweather uses the Hypack® Hysweep acquisition software package to log all Reson MBES data. Hysweep displays real-time MBES coverage geo-referenced against supporting background files such as charts and vector shoreline files for launch and ship helmsman to follow to acquire adequate MBES coverage. The Hypack Devices (Hysweep Interface, Applanix POS MV Network, and MVP) and Hysweep Hardware (Hypack Navigation, Applanix POS MV Network, and Reson) *.ini files are created with the support of HSTP field support liaison and are in accordance with HSTP's configuration management documentation.

Three types of files are recorded per logged line of Reson MBES data: .raw, .hsx, and .7k. The .raw file contains the raw navigation files recorded directly from the POS MV (as device 0) and from Hysweep (as device 1). The .hsx files contain data from Hypack Navigation (as device 0), POS MV (as device 1), and the Reson MBES (as device 2). The .7k file contains all raw data that Hysweep can read from the Reson, including the Reson 7008 snippets message.

The .hsx and .raw files are converted into HDCS data in CARIS HIPS by *Fairweather* personnel. The .7k file is not post-processed by *Fairweather* personnel but is recorded for and submitted with the other raw data for outside backscatter research, processing and product development. All three raw files are submitted directly to NGDC for archival. Additionally, the MBES sensor offsets and mounting biases are entered into the respective vessel's Hysweep Hardware device to facilitate later backscatter processing using Hypack GeoCoder. Entry of device offset values in Hysweep Hardware causes the values to be logged in the header of the .hsx only, and does not affect the data pipeline. These values are not tracked or closely monitored aboard *Fairweather* because they are not otherwise integral to meeting the requirements of the 2012 HSSD.

2.2.2 CARIS Notebook

CARIS Notebook™ can be used to directly collect detached shoreline positions and to verify shoreline. The software is run on a field computer and receives the Trimble GPS data output from the GPS Pathfinder® Pro XRS receivers.

GPS settings in CARIS Notebook are as follows:

Maximum Horizontal Dilution of Precision (HDOP) = 3

Maximum Positional Dilution of Precision (PDOP) = 6

Minimum Signal-to-Noise Ratio (SNR) = 12

Minimum Elevation Mask = 8°

Minimum # of Satellites = 4

Real-Time settings in CARIS Notebook are as follows:

Source Type: Integrated Beacon – Manual Mode

Position Mode: Corrected Only

Age Limit: 20 seconds

Differential GPS correction is applied in real-time using the unit's integrated beacon as the primary corrector. The unit can be setup to run without using DGPS with position mode set to

“Autonomous Only” or with values different than those listed above. These special circumstances of acquisition with altered parameters are recorded and documented in the individual Descriptive Report as appropriate.

2.2.3 Klein SonarPro

Klein SonarPro is a custom display and acquisition software package for use with Klein Side Scan sonar systems. *Fairweather* uses SonarPro to monitor the quality of real-time imagery and to log raw side scan files in .SDF file format while acquiring Klein 5000 Side Scan data from the sled-mounted systems configurable on any of *Fairweather's* launches. Vessel navigation data from the POS MV is supplied to SonarPro and logged in the SDF file. The raw SDF files are converted using CARIS SIPS into HDCS files for post processing and analysis.

2.3

2.3.1 Applanix POSView

Applanix POSView is the controller software for the POS MV. POSView is used to configure the serial and network input and output ports on the POS MV PCS. POSView is also used to monitor real-time position and attitude data and their associated accuracies and to log POSPac .000 files. The POSPac .000 file contains the TrueHeave information that is applied to the MBES HDCS data in CARIS HIPS immediately after conversion. The POSPac .000 file is also post-processed into a PPK SBET file using Applanix's POSPac processing software.

2.4 Data Processing Software

2.4.1 CARIS

CARIS HIPS™ (Hydrographic Information Processing System) is used to process all multibeam data including data conversion, filtering, sound speed corrections, tide correction, merging and cleaning. CARIS HIPS also calculates the Total Propagated Uncertainty (TPU) used to produce Bathymetry Associated with Statistical Error (BASE) surfaces which assist the Hydrographer in data cleaning and analysis, and to produce BASE surfaces.

CARIS SIPS™ (Sonar Information Processing System) is used to process all side scan imagery data including data conversion, altitude adjustment, slant-range correction, and beam pattern correction. CARIS SIPS is also used to inspect the imagery for contacts and to produce side-scan imagery mosaics.

CARIS Notebook™ and CARIS Bathy DataBase™ BASE Editor (BDB) are used to compile, display, and edit source shoreline, shoreline updates and S-57 features that are collected directly in the field. The .hob files created in Notebook and BDB are the current shoreline deliverables.

CARIS Bathy DataBase™ BASE Editor is also used for data quality assurance checks on the BASE surface and for surface differencing.

CARIS Plot Composer is used to create final field plots and special constituent products.

2.4.2 Fledermaus™

Fledermaus™, an Interactive Visualization Systems 3D™ (IVS 3D) program, is used for data visualizations and creation of data quality control products, public relations material and reference surface comparisons.

2.4.3 Geocoder

The use of any Geocoder software by *Fairweather* personnel to check Reson Snippet backscatter data and/or to create backscatter mosaics will follow best practices established by NOAA personnel to date. If warranted, specifics of its use or findings for a given survey will be documented in the individual descriptive report.

2.4.4 Applanix POSPac MMS and POSGNSS

Applanix POSPac MMS and POSGNSS are used to post process POS MV data files logged simultaneously during MBES acquisition. The Single Base PPK processing method is typically used when a single *Fairweather* or third party GPS base station is operating within approximately 20 kilometers of MBES acquisition. The SmartBase™ PPK processing method is used when a stable network of approximately 5-10 available third party GPS base stations such as those in the Continuously Operating Reference Station (CORS) system or Plate Boundary Observatory (PBO) suite of stations exists within approximately 200 kilometers of MBES acquisition. On occasion Precise Point Positioning (PPP) is used when sufficient base stations are not available for Single Base or SmartBase™ PPK. In general, *Fairweather* processing procedures follow the methods outlined in the *POSPac MMS GNSS-Inertial Tools User Guide* for each method. Processing methods specific to each project are documented in the Project Horizontal and Vertical Control Report. Processing methods specific to each survey are documented in the Descriptive Report

2.4.5 Velocipy

Velocipy is a NOAA in-house software supported by the Hydrographic Systems and Technology Program (HSTP) that is used to process raw sound velocity cast files taken with the SEACAT CTDs on the launches and the MVP from the ship. Velocipy creates CARIS format .SVP files that are applied during post processing in HIPS to MBES HDCS data to correct for sound speed. The individual CTD and MVP files are concatenated into a single vessel file by survey. Each vessel file contains the survey registry number and the time and location of each sound speed profile measured.

2.4.6 Pydro

Pydro, another NOAA program produced and maintained by HSTP, is used to produce Final Water Level Requests along with DTON Reports and Survey Feature Reports. The xml Descriptive Report (DR) is produced using the xmlDR component of Pydro, the DR pdf file is then produced via a stylesheet. In addition, Pydro is used for Tidal Constituent and Residual Interpolation (TCARI) tide application in conjunction with CARIS HIPS and various other macros.

Pydro is utilized to assist with sidescan and multibeam contact correlation. Information about each contact is easily entered, images can be added and a final feature report can be produced.

3.0 Vessels

3.1 Vessel Inventory

Fairweather (S220) and her survey launches 2805 and 2808 are equipped to acquire multibeam echosounder (MBES) and sound speed profile (.svp) data. The AMBAR (2302) and Metal Shark skiff (1810) are used primarily during shoreline verification, bottom sampling, and horizontal and vertical control operations. All vessels may be used in support of dive, tide gauge, and horizontal control operations as well as for feature verification and bottom sampling. See Appendix I for the complete vessel inventory.

4.0 Data Acquisition

4.1 Horizontal Control

A complete description of horizontal control will be included in the project's *Horizontal and Vertical Control Report (HVCR)*, submitted for each project under separate cover when necessary as outlined in section 8.1.5.2 of the *HSSD* and section 5.2.3.2.3 of the *FPM*.

The horizontal datum for all projects is the North American Datum of 1983 (NAD83) unless otherwise noted in the individual descriptive reports.

Multibeam and shoreline data are differentially corrected in real time using correctors provided by Coast Guard beacons. The specific beacons used for a given survey will be included in the Horizontal Control section of the survey's descriptive report. If loss of the differential beacon resulted in any data being recorded with C/A GPS positions it will be noted in the Descriptive Report for the specific survey.

When possible, real time DGPS positioning may later be replaced with a post processed kinematic (PPK) single best estimate of trajectory (SBET). The PPK solution is usually dependent on a local base station supported by the ship and processed in Applanix POSPac MMS software using Single Base mode. However, in areas with an adequate network of Continuously Operating Reference Stations (CORS) or public third-party base stations, Applanix POSPac SmartBase™ mode may be used. The resulting navigation from PPK is an improvement over C/A and DGPS navigation. The details of PPK use and application for a given survey will be included in the Horizontal Control section of the project's *HVCR* or the survey's descriptive report.

4.2 Multibeam Echosounder Acquisition and Monitoring Procedures

Acquisition methods and platforms used are determined based on consideration of sonar system specifications, seafloor topography, water depth, and the capability of the acquisition platforms.

All multibeam data are acquired in Hypack's Hysweep® SURVEY extension (.hsx) format and monitored in real-time using the 2-D and 3-D data display windows and the on-screen displays for the Reson 7125 SV, Reson 7111, and Reson 8160. Adjustable parameters that are used to control the Reson include range scale, power, gain, pulse width, absorption, and spreading. These parameters are adjusted as necessary to acquire the highest quality of bathymetry and backscatter. Vessel speed is predominantly between 6-8 knots for acquisition with launch 7125 SV systems. For Reson 7111 and Reson 8160 acquisition systems, vessel speeds are 6-7.5 knots. Speeds are reduced as needed to eliminate noise from the data and to ensure the required along-track coverage for object detection in accordance with the *HSSD*. Ship survey speed is increased to as fast as 10 knots for track line surveys without along track density requirements.

Survey personnel follow standard operating procedures documented aboard *Fairweather* while setting and utilizing the Reson systems and Hypack for data acquisition. The sensor offsets and mounting biases are entered into the Hysweep® Hardware Reson device. This information is recorded in the Hypack hsx file header for corrected backscatter mosaics created with Hypack Geocoder. These offsets do not have any effect on CARIS HIPS HDCS sounding corrections.

Navigation and motion data are acquired and monitored in POSView and logged into a POS MV file with a .000 extension. Various position and heading accuracies, as well as satellite constellations, are monitored real-time both in POSView and Hypack Hysweep®.

Main scheme MBES acquisition lines using the Reson 7125 SV, Reson 7111, and Reson 8160 are generally run parallel to the contours and spaced no greater than three to four times the water depth and in most cases at a tighter line spacing to ensure the appropriate data density for the required finalized BASE surface resolutions. For discrete item developments, line separation is reduced to two times the water depth to ensure least-depth determination by multibeam near-nadir beams. Hypack Hysweep® real-time coverage display is used in lieu of pre-planned line files. Hysweep® displays the acquired multibeam swath during acquisition and is monitored to ensure overlap and full bottom coverage. If coverage is not adequate, additional lines are run while still in the area.

For areas where shoreline verification is not conducted before multibeam, extra caution is taken by "half stepping" shoreward when operating near shore. Half stepping is done by driving along the edge of real time coverage to prevent the survey vessel from ever being in un-surveyed waters. Survey launch crews in the field survey to the Navigable Area Limit Line (NALL) line as defined by section 1.1.2 of the *HSSD*.

4.3 Shoreline/Feature Verification

The composite source file (CSF) in S-57/.000 format provided with the Project Instructions is the primary source for shoreline features to be verified. The original project file is imported into CARIS Notebook, converted to a .hob file, clipped to the sheet limits for the specific survey, and named H#####_Original_Composite_Source.hob to be included with the deliverables. This file is then copied and named H#####_Feature_File.hob to be utilized

during field verification. Additionally, AWOIS items and other features to be investigated are provided to the field in the project reference file (PRF).

Fairweather personnel conduct limited shoreline verification and reconnaissance at times near predicted negative tides within the survey limits when possible, as directed by section 3.5.5.3 of the *FPM*. Detached positions (DPs) are acquired and edits to the daily field feature files are recorded in CARIS Notebook and on paper DP forms and boat sheets.

An inshore limit buffer line, offset 0.8 mm from the Mean High Water (MHW) line at the scale of the largest chart in the area, is provided with the Project Instructions. This inshore limit buffer line is used in the shoreline acquisition software and on the boat sheet as a reference, and utilized as described in section 1.1.2 of the *HSSD*. The NALL is determined in the field as the farthest off-shore of one of the following; the MHW inshore limit buffer specified above, the 4-meter depth contour, or the inshore limit of safe navigation as defined by the *HSSD*. All shoreline features from the CSF seaward of the NALL are verified (including an update to depth and/or position as necessary) or disproved during operations. Features off-shore of the NALL and not addressed or features of an ambiguous nature include remarks for further clarification. Specifically assigned features may be investigated that are inshore of the NALL in accordance with the associated instruction for a given project area.

Detached positions (DPs) acquired during shoreline verification indicate new features, revisions to source features, or source features not found in the field. They are recorded in the shoreline acquisition software and on DP forms.

4.4 Bottom Samples

Bottom samples are acquired according to section 7.1 of the *HSSD*, any deviations from this protocol will be outlined in the individual Descriptive Report for the survey. Samples are acquired using CARIS Notebook, Hypack target files (.tgt), or by logging the latitude, longitude, and bottom characteristics manually. All samples are processed similarly to other shoreline features as outlined below in section C - 2.2 of this report. Bottom sample results are included in the Notebook .hob deliverable layer, HXXXXXX_Final_Feature_File and are descriptively attributed as New.

4.5 Sound Speed

Sound speed casts are taken at least once every 1–4 hours during multibeam survey operations in accordance with section 3.5.1 of the *FPM*. *Fairweather's* launches collect sound speed casts approximately every 3 hrs utilizing the SBE 19*plus* SEACAT sound speed profilers. *Fairweather* collects sound speed casts every 15- 30 minutes with the MVP dependant on the variability of sound speed conditions. When the MVP is being serviced, casts with the SBE 19*plus* units are also conducted by the ship at least every 4 hours. Deviations from this procedure will be outlined in the individual Descriptive Report for the survey.

C. QUALITY CONTROL

Fairweather has numerous standard operating procedures (SOPs) that are followed by personnel throughout the survey to ensure consistent high quality data and products.

1.0 Uncertainty Modeling

Uncertainty values for the multibeam and positioning systems on *Fairweather* and her survey launches were compiled from manufacturer specification sheets for each sensor (Heave, Pitch, Roll, Position, and Heading) and from values set forth in section 4.2.3.8 and Appendix 4 – CARIS HVF Uncertainty Values of the 2012 *FPM*.

The manufacturer specification for POSMV heading accuracy is contingent on a 2 meter baseline between primary and secondary GPS antennas. While the *Fairweather* has a 2 meter baseline her launches have on average a 1.4 meter baseline which has been seen to increase accuracy estimates in the field. Based on observations in the field, the heading error value for all launches has been increased from the manufacturer specification and FPM guidance to 0.04 degrees.

Estimates for the Motion Reference Unit (MRU) alignment errors are taken from the standard deviation of the values determined by multiple personnel processing the patch test data (see section D 4.0). In some instances, outlier patch test values are excluded to allow more reasonable MRU uncertainty values.

The *Fairweather* TPU Values spreadsheet located in Appendix III, lists the final uncertainty values for *Fairweather* and her launches, including the default tides and sound velocity values. Uncertainty values relating to vessels and survey systems are entered into the HIPS Vessel File (HVF) for each platform. The tidal errors for the gauge and for zoning are determined on a project by project basis. Sound speed uncertainties for a given survey are based upon either the defaults listed in the TPU value spreadsheet or based on utilization of NOAA sound speed uncertainty estimation software. Survey specific uncertainty values for tides and sound speed that are entered during the Compute TPU step in CARIS HIPS and how they were determined will be included in the individual Descriptive Report. After SBET application, TPU values are recalculated using the Error Data option for Uncertainty Source in the CARIS Compute TPU window. This loads more precise residual mean square (RMS) values to selected HDCS lines for position, roll, pitch and gyro.

2.0 Data Processing

2.1 Multibeam Echosounder Data Processing

Bathymetry processing followed section 4.2 of the *FPM* unless otherwise noted.

Raw .hsx multibeam data are converted to CARIS HIPS HDCS format using established and internally documented settings. After TrueHeave™, sound speed, and water level correctors are applied to all lines, the lines are merged. Once lines are merged, Total Propagated Uncertainty (TPU) is computed.

The general resolution, depth ranges, and Combined Uncertainty and Bathymetric Estimator (CUBE) parameter settings outlined in section 5.2.2.2 of the *HSSD* and section 4.2.1.1.1.1 of the *FPM* are used for surface creation and analysis. If these depth range values for specific resolutions require adjustment for analysis and submission of individual surveys then a waiver from HSD Operations is required and would be requested. A detailed listing of the resolutions

and the actual depth ranges used during the processing of each survey, along with the corresponding fieldsheet(s), will be provided in the Descriptive Report of each survey.

BASE surfaces are created using the CUBE algorithm and parameters contained in the NOAA CUBEParams_NOAA.xml file as provided in Appendix 4 of the *FPM*. The CUBEParams_NOAA.xml will be included with the HIPS Vessel Files with the individual survey data. The NOAA parameter configurations for resolutions 1-32 meters are used.

Multibeam data are reviewed and edited in HIPS subset mode and in swath editor as necessary. The finalized BASE surfaces and CUBE hypotheses are used for directed data editing at the appropriate depth range in subset editor. The surfaces and subset editor view are also used to demonstrate coverage and to check for errors due to tides, sound speed, attitude and timing.

Vessel heading, attitude, and navigation data are reviewed in HIPS navigation editor and attitude editor if deemed necessary upon review of surfaces. Where necessary, fliers or gaps in heading, attitude, or navigation data are manually rejected or interpolated for small periods of time. Any editing of this nature will be outlined in the Descriptive Report for the particular survey.

Due to the increased sounding densities seen during data collection, the Density method for hypothesis disambiguation is used. This is a deviation from section 4.2.1.1.1 of the *FPM* which lists the default method as Density & Locale, this former method produced surfaces which were less likely to honor distinct features.

The Surface Filtering functionality in HIPS may be used in the processing of survey data to reject errant soundings. If utilized, the individual Descriptive Report shall list the confidence level settings for standard deviation used and discuss the particular way the surface filter was applied.

In depths less than 20 meters and deeper and in areas of navigational significance where the BASE surface does not depict the desired depth for the given area, a designated sounding is selected. Designated soundings are selected as outlined in section 5.2.1.2 of the *HSSD*.

Layers determining “IHOness” are added to the CUBE surfaces allowing the Hydrographer to see where and if the surfaces meet IHO Order. The process is easily performed in HIPS and allows the Hydrographer to identify areas of high uncertainty with respect to depth. This is a spatial quality control check rather than just a statistical list of nodes and allows for specific areas with problems to be isolated and addressed. The following logic equation is used to create “IHO_1” child layers in the 1 through 8 meter finalized surfaces:

IHO-1: $-\text{Uncertainty}/((0.5^2 + ((\text{Depth} * 0.013)^2))^0.5)$,

and an “IHO_2” child layer is created in the 8, 16 meter, and greater finalized surfaces using

IHO-2: $-\text{Uncertainty}/((1.0^2 + ((\text{Depth} * 0.023)^2))^0.5)$.

It should be noted that both IHO order 1 (~80 to 100) and order 2 (100 to 176) child layers are created for the 8 meter surface since it overlaps the order 1 and order 2 boundary (order1<100 meters, order 2>100 meters). IHO surfaces are utilized during data collection and processing as an additional child layer of the finalized surfaces to indicate problem areas that need attention or discussion. Additionally, the percentage of IHO nodes passing from the combined finalized surfaces is included in the Descriptive Report for each survey. Statistics on node percentage are computed using a python script created by Weston Renoud which is retained on *Fairweather*. For visual depiction of localized areas that do not meet IHO standards, screen grab(s) of the individual finalized IHO child layer(s) may also be included.

The individual finalized or combined surface's IHO layers are exported from CARIS as a text file and examined to allow the Hydrographer to see the full data distribution rather than just the minimum and maximum values in the surface. These data distribution are used to assess the quality of the survey, to ensure ninety-five percent of the data meets the appropriate IHO order as specified in section 5.1.3 of the *HSSD*.

Additionally, a combined surface is reviewed in 3-D mode using one of the following programs, CARIS HIPS, CARIS Base Editor, or IVS Fledermaus, to ensure that the data are sufficiently cleaned for submission.

2.2 Side Scan Sonar Data Processing

Side scan processing followed section 4.3 of the *FPM* unless otherwise noted.

Raw .sdf side scan data are converted to CARIS SIPS HDCS format using established and internally documented settings. The towfish navigation is recomputed and slant range corrections are completed. For hull mounted configurations the towfish navigation is recomputed using a zero value for cable out. For a towed configuration, both cable out and towfish depth are recorded in the raw data and used to recompute the towfish navigation.

The side scan sonar system must be able to detect an object on the sea floor that measures 1m x 1m x 1m and is ensonified a minimum of three times per pass. The effective range for the side scan is to operate the towfish height 8-20 percent of the range scale.

Daily checks are required to ensure the minimum size objects are being detected. This is accomplished as passing by a buoy moorings, wreck or known object. The object must be detected on both the port and starboard channels.

The data is reviewed and objects are selected based on depth of water and height of shadow. If the depth is less than 20 meters then any object with a shadow of 1 meter is considered significant. Significant contacts in depths greater than 20 meters are defined as an object that rises off the seafloor at 10 percent of the water depth. All selected contacts are imported to Pydro and correlated based on location and notes are added as to whether the object is significant. Significant contacts are investigated further with multibeam echosounder.

A mosaic of the side scan data is created using CARIS Mosaic Editor to assess coverage and one mosaic should be created for each 100 percent completed. Side scan mosaics should be 1 meter by 1 meter pixel resolution.

2.3 Shoreline/Feature Data Processing

During shoreline verification, field detached positions (DP) are acquired with CARIS Notebook or Hypack .tgt files. Tide application for features requiring tide correction is applied in CARIS Notebook when using discrete zoning and with the aid of Pydro when TCARI is used.

New features and any updates to the composite source shoreline, such as ledges or reefs, are acquired or digitized with S-57 attribution and are compiled from the field daily files into the H#####_Final_Feature_File.hob. Updates to source shoreline features primarily include a change in depth/height, position, or S-57 classification. Notebook's editing tools are used to modify source feature extents or positions.

The SORIND and SORDAT S-57 attribute fields for new features or modified source features are updated to reflect the information for the associated survey number and date (US,US,graph,H#####). All new or modified features are S-57 attributed as applicable and descriptively attributed as New or Update respectively. All unmodified source features retain their original SORIND and SORDAT values. Assigned features that are addressed but not updated are descriptively attributed as Retain and unaddressed assigned features are attributed as Not Addressed.

Short descriptive comments taken from the boat sheets or DP forms along with investigation or survey methods are listed under the Remarks field. For significant features that deserve additional discussion, the Hydrographer may include a recommendation to the cartographer in the Recommendations field, along with the Hydrographer notes and investigation methods provided in the Remarks field.

Features that are disproved or that do not adequately portray the shoreline are descriptively attributed as Delete in the H#####_Final_Feature_File.hob layer. Features with the attribution of Delete retain their original SORIND and SORDAT values and include a recommendation from the Hydrographer along with an informative remark.

AWOIS investigation items are received in the Project Reference File and investigated as necessary. Features correlated to the AWOIS item are included in the H#####_Final_Feature_File.hob layer and labeled with the appropriate AWOIS number and include a remark detailing the search methods and a recommendation from the Hydrographer. Items will be attributed as AWOIS for reporting purposes. Any features that are submitted as dangers to navigation (DTON) will be attributed accordingly for reporting purposes. The status of Primary or Secondary may be attributed to aid in deconflicting multiple positions or instances of the same feature.

Images are labeled and associated with a DP/userid number or other descriptive/unique name. They are included with the survey data and stored in the CARIS/Multimedia folder with the

deliverables. References to the images are listed with file extension and comma delimited in the Images attribute for the specific feature.

The CARIS Notebook files along with CARIS HIPS BASE surface(s) are viewed to compare MBES coverage and features simultaneously. The current NOAA object catalog will be used for CARIS Notebook processing and the version of such will be documented in the individual Descriptive Reports, along with any deviations in shoreline processing from those listed above.

Final shoreline deliverables are two S-57 (*.000) files exported from Notebook, the H##### Original Composite Source and the H##### Final Feature File, included with the processed data.

3.0 Data Review

Specific procedures are used on *Fairweather* to ensure quality control of data throughout acquisition, processing, and submission. These procedures are documented and followed by the Hydrographer. A detailed Quality Control check is performed by the survey manager. A detailed review is conducted by qualified survey personnel (FOO, CST, SST, or PS) other than the survey manager as an outside review of the survey data and deliverables. Submission checklists are used to ensure that all data and deliverables are complete and included upon submission. Documentation of these tasks is completed for every survey but only the final processing log, H##### Data Log, is included in the Separates submitted with the individual survey data.

D. Corrections to Echo Soundings

1.0 Vessel HVFs

CARIS HIPS Vessel Files (HVF) are created by *Fairweather* personnel and used to define a vessel's offsets and equipment uncertainty. The HVF is used for converting and processing raw Hypack .hsx and .raw files to CARIS HIPS HDCS format. The HVFs used for a given project are included with the digital data submitted with the survey.

2.0 Vessel Offsets

Sensor offsets are measured with respect to each vessel's reference point. The reference point for *Fairweather* and her survey launches 2805 and 2808 is the top, center of the POS MV IMU (Figure 17). The offset values from the reference point to the primary GNSS antenna are entered into Applanix's POSView POS MV monitoring software so that all raw position data are centered at the vessel's reference point. The CARIS HVF contains the offset from the vessel's reference point to the multibeam sonar reference point.



Figure 17: Vessel Reference Point (Top of POS MV IMU) & Primary GNSS Antenna (port side).

Additionally, the Reson sonar mounting offsets measured from the center of each projector to the center of the transceiver are entered in the Reson 7125 hardware configuration with the 7K Center for both the 400 kHz and 200 kHz projectors. The measured values are used instead of Reson's default values because *Fairweather's* mounts are slightly different than of Reson's standard sonar mount (Figure 18).



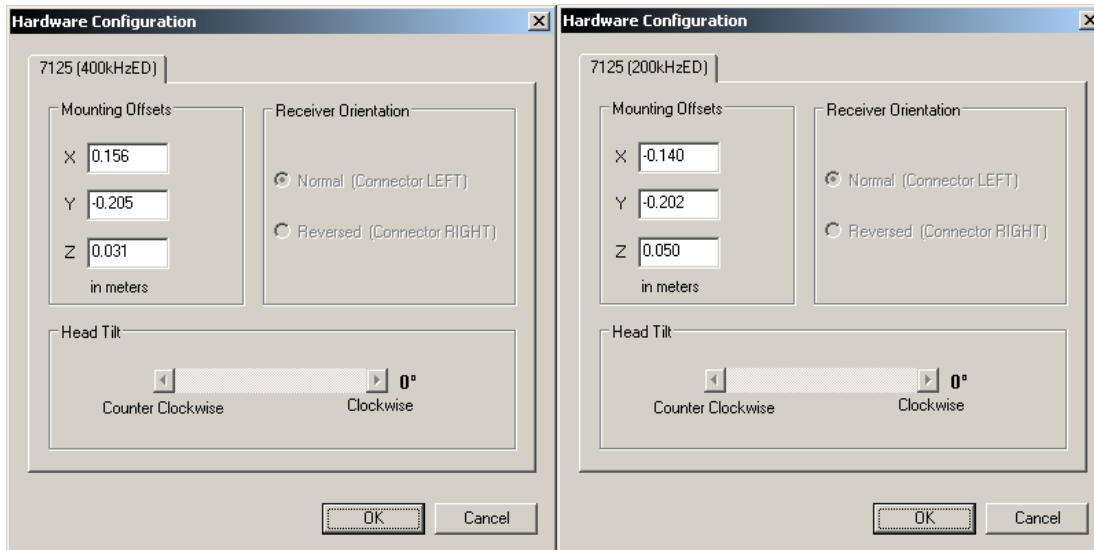

Figure 18: Reson 7125 sonar mounting with 400kHz and 200kHz offsets respectively.

A ship survey of *Fairweather* was completed by Westlake Consultants, Inc on September 23, 2003. A spatial relationship survey of *Fairweather* POS MV components was conducted by NOAA's National Geodetic Survey (NGS) in February 2007, and again on February 15, 2009, while the ship was in Lake Union Drydock in Seattle, WA. The results of the Westlake, the 2009 NGS survey, and additional offset values discussed below in section D 4.0 are used to determine the offsets for the ship. The reports from each survey, whose values are used for the offset measurements, are located in Appendix II. The S220 Offsets & Measurements spreadsheet is also included in Appendix II, listing the final values for *Fairweather's* offsets with explanations of how they were calculated.

Permanent control points were established on launches 2805 and 2808 during construction at All American Marine in 2009. Sensor offsets were measured by NGS in January 2010 using the methods described in the report on each launch located in Appendix II of this report. The resultant offsets, measurements, derivations, descriptions of methodology used, diagrams, and coordinate system references are included in the respective vessel's Offsets & Measurements spreadsheet also included in Appendix II.

3.0 Static and Dynamic Draft

The static drafts (Waterline Height in the HVF) for launches 2805 and 2808 were calculated based on steel tape and plumb bob measurements of the distance from benchmarks on the port and starboard quarter of the vessel to the waterline. The values and calculations for static draft of the various launches are listed in the respective Waterline Measurement spreadsheets included in Appendix II of this report.

The static draft of *Fairweather* was measured under different loading conditions with different amounts of fuel. The bow and stern draft marks were recorded and then used to perform a linear interpolation of the static draft at *Fairweather's* IMU. The Ship Draft 2012 spreadsheet

records the static draft values and is included with the ship offset documentation in Appendix II.

Fairweather's dynamic draft measurement was taken May 10, 2012 in Puget Sound. The dynamic draft data were acquired for launches 2805 and 2808 in Newport, OR in the Yaquina River. Data was acquired at slack current and values agreed well with the previous year. The measurements were made using the change in ellipsoid height while the vessels were transiting at different speeds in their respective locations. The ellipsoid heights were determined using Post Processed Kinematics (PPK) by recording POSPac data on each vessel and then processing the data with local reference stations in Applanix POSPac MMS software. The resulting Single Best Estimate of Trajectory (SBET) was exported from POSPac and the speed versus ellipsoid height was fit to a third order polynomial curve using a least squares fit method in a Python Script written by NOAA personnel and implemented within Pydro. When available MLLW verified levels were loaded into Pydro for dynamic draft locations influenced with tides. The polynomial curve was used to derive the table used in the CARIS HVF, and the standard deviation of the residuals was used to determine the associated uncertainty in the measurement. Written reports for each platform including initial measurement notes, graphs, and finalized values are provided in Appendix II of this report. The polynomial best fit curve of the ellipsoidal height differences from launches 2805 and 2808 compare well with each other and previous years. The dynamic draft offset values and standard deviations were then entered into the CARIS HVFs.

4.0 Patch Tests

Patch tests were conducted in accordance with section 5.2.4.1 of the HSSD on launches 2805 and 2808 for the Reson 7125 SV MBES sonar systems during the months of March and April 2012 using the Shilshole Bay Reference Surface and Patch Test site near Seattle, WA. Patch tests were also conducted for *Fairweather's* -Reson 8160 and Reson 7111 MBES sonar systems using the Shilshole Bay Reference Surface and Patch Test site. The patch test results for the 8160 system were deemed unreliable and the 2011 patch test values were used as no changes were made to the configuration of that sonar. The results of all patch tests to date, along with the acquisition and processing logs, are included in the individual MBES Calibration files in Appendix II.

Also included in Appendix II is the sounding system comparison. This comparison includes surface differencing between all launch and ship MBES reference surfaces using CARIS Bathy Database. The results of both comparisons show that the differences between each platform and sonar are within NOAA specification for vertical uncertainty.

5.0 Attitude and Kinematic Data

Vessel attitude is measured by the POS MV and recorded in the Hysweep .hsx file. Roll is applied real time to Reson 8160 and Reson 7125 SV data. Pitch is applied real time to Reson 7111 and Reson 8160 data. Attitude measurements not applied in real time (heave, pitch, roll, and heading) are applied during post processing in CARIS HIPS using the raw POS MV attitude data recorded in the Hysweep .hsx file. Post processed kinematic (PPK) data from the POS MV .000 file are applied to MBES data in CARIS HIPS in the form of SBET files once all data acquisition is complete.

5.1 TrueHeave™

The POS MV TrueHeave™ data is logged within the POS MV .000 files and applied in CARIS HIPS during post processing using the “Apply TrueHeave” function. TrueHeave™ is a forward-backward filtered heave corrector as opposed to the real time heave corrector, and is fully described in Section 6 of the *POS MV V4 User Guide 2009*. To ensure proper application in CARIS HIPS, POS MV files are logged for at least three to five minutes before and after all MBES files are logged.

If the POS MV files fail to apply in CARIS HIPS during the “Apply TrueHeave” process the files are fixed using a CARIS tool called “fixTrueHeave.exe.” In cases where this is necessary a new fixed file is created with the extension “.fixed” (2011-ddd-vssl.000.fixed). The new fixed TrueHeave™ file is then applied to the data in CARIS HIPS. The original corrupted file is retained along with the fixed file with the submitted Global Navigation Satellite System (GNSS) data. Occurrences of this for specific surveys are noted in the individual Descriptive Reports.

In cases where TrueHeave™ cannot be applied, real time heave correctors are used. Real time heave data are recorded and stored in the Hypack Hysweep .hsx file and are applied as the heave corrector for MBES data if TrueHeave™ files are unavailable. Data that do not have TrueHeave™ applied will be listed in the individual Descriptive Report for the survey.

5.2 Post Processed Kinematic Data

Post Processed Kinematic (PPK) data in the form of Single Best Estimate of Trajectory (SBET) files are applied to soundings to increase the accuracy of the kinematic vessel corrections and to allow the ability to reference soundings to the ellipsoid.

Standard daily data processing procedures aboard *Fairweather* include post processing of POS MV kinematic .000 files using Applanix POSpac MMS and POSGNSS software using either Single Base or SmartBase batch processing methods as described in section B.2.3.4. After processing and quality control analysis of the post-processed SBET files is complete, the SBET and SMRMSG files are applied to the HDCS data in CARIS HIPS using the “Load Attitude/Navigation Data”, the “Load error data...”, and “Compute GPS Tide” processing tools. Ellipsoidal heights are contained within the PPK SBET files. Soundings to which SBETs have been applied can be reduced to the ellipsoid by merging the data in CARIS HIPS with “GPS Tide” applied. Data are frequently referenced to the ellipsoid during data analysis for troubleshooting unexplained vertical offsets.

Positioning of features and bottom samples is not corrected with post processed GNSS data because at this time as there is not a developed nor streamlined procedure for PPK application to features.

6.0 Sound Speed

Seabird SBE 19*plus* and SBE 19*plus*V2 sound speed profilers are used regularly to collect sound speed data for the Reson 7125 SV MBES systems on survey launches 2805 and 2808, and used on an as needed basis for *Fairweather*'s Reson 7111 and Reson 8160 MBES systems. The Brooke Ocean Technology Moving Vessel Profiler (MVP) is primarily used to collect sound speed data for sound speed correction of data acquired with *Fairweather*'s Reson 7111 and Reson 8160 MBES systems unless otherwise noted in the individual descriptive reports.

Daily sound speed profiles from the SBE 19*plus* and SBE 19*plus*V2 profilers are processed with Velocipy and concatenated into single .svp files for each vessel per survey. Individual .svp files and the concatenated vessel files for the survey are submitted with each survey.

Sound speed profiles acquired using the Brooke Ocean Technology Moving Vessel Profiler 200 (MVP) are stored in files labeled BOT_XXXX.calc, where X is the incrementally increasing cast number. The .calc file for each cast is opened with Velocipy and converted into CARIS .svp file format. The individual .svp profiles are concatenated into vessel specific .svp files for the entire survey. Individual sound speed profiles taken by the MVP are not submitted separately due to the large number of casts acquired and the way in which they are processed; however, the daily concatenated files are submitted for backup purposes and include all profiles acquired.

The concatenated sound speed files are applied to multibeam data in CARIS HIPS during data processing. CARIS HIPS uses one of four different methods to automatically apply a sound speed profile stored in a concatenated sound speed file. They are: "previous in time," "nearest in time," "nearest in distance" and "nearest in distance within time." The method of applying sound speed for a specific day of data collection is listed in the daily logs included as Separates submitted with the individual survey data.

7.0 Water Level

Unless otherwise noted in the survey Descriptive Report, the vertical datum for all soundings and heights is Mean Lower Low Water (MLLW). Predicted, preliminary, and/or verified water level correctors from the primary tide station(s) listed in the Project Instructions may be downloaded from the CO-OPS website and used for water level corrections during the course of the project. These tide station files are collated to include the appropriate days of acquisition and then converted to CARIS .tid file format using FetchTides.

Water level data in the .tid files are applied to HDCS data in CARIS HIPS using the zone definition file (.zdf) or a Tidal Constituent and Residual Interpolation (TCARI) model supplied by CO-OPS. Upon receiving final approved water level data, all data are reduced to MLLW using the final approved water levels as noted in the individual survey's Descriptive Report.

A complete description of vertical control utilized for a given project can be found in the project specific *Horizontal and Vertical Control Report (HVCR)*, submitted for each project under separate cover when necessary as outlined in section 5.2.3.2.3 of the *FPM*.

Appendix I

System Tracking

1. Vessel Inventory
2. Hardware Inventory
3. Computer Inventory

Sound Speed Calibration Documentation

1. Moving Vessel Profiler
2. ODOM Digibar
3. SPE 19+
4. SPE 19+ V2
5. SVP 70
6. SVP 71

Hydrographic Vessel Inventory

Field Unit: FAIRWEATHER
 Effective Date: April 10, 2012
 Updated Through: November 29, 2012

SURVEY VESSELS						
Vessel Name	FAIRWEATHER	Launch 2805	Launch 2808	Ambar 700	Skiff	FRB
Hull Number	S 220	2805	2808	2302	1810	2301
Call Letters	WTEB					
Manufacturer	Aerojet-General Shipyards	All American Marine	All American Marine	Marine Silverships, Inc	Metal Shark	Zodiak of North America
Year of Construction	1967	2009	2009	1998	2012	2004
Type of Construction	Welded steel hull - ice strengthened	Welded Aluminum	Welded Aluminum	RHIB (Aluminum)	Welded Aluminum	RHIB (Fiberglass)
Length Overall	70.4 m (231')	8.64 m (28' 6")	8.64 m (28' 6")	7.0 m (23')	4.57 m (15')	6.7 m (22')
Beam	12.8 m (42')	3.48 m (11' 5")	3.48 m (11' 5")	2.9 m (9' 4")	4.44(8')	2.6 m (8' 6")
Draft	4.7 m (15' 6")	1.12 m (3' 8")	1.12 m (3' 8")	0.4 m (1' 4")	(18")	0.6 m (22")
Cruising Speed	12.5 knots	24 knots	20 knots	22 knots	16 knots	18 knots
Max Survey Speed	8 knots	8 knots	8 knots			
Date of Effective Full Vessel Static Offset Survey	Original Survey 9/23/2003 POS/MV Offsets Surveyed 2/2007 and 2/15/2009	1/26/2010	1/27/2010			
Organization which Conducted the Effective Full Offset Survey	Original Survey - Westlake Consultants POS/MV Spatial Surveys - NGS	NGS/GSD	NGS/GSD			
Date of Last Partial Survey or Offset Verification & Methods Used	n/a	n/a	n/a			
Date of Last Static Draft Determination & Method Used	6/3/2011 Draft Marks	3/25/2011 Direct Measurement from benchmarks.	3/14/2011 Direct Measurement from benchmarks.			
Date of Last Settlement and Squat/Dynamic Draft Measurements & Method Used	6/3/2011 Post Processed Kinematic (Ellipsoidally referenced)	3/25/2011 Post Processed Kinematic (Ellipsoidally referenced)	3/02/2011 Post Processed Kinematic (Ellipsoidally referenced)			

Orange - info needs to be verified

GREY - not applicable

2012 FA Hardware Inventory

Item Name	Serial #	Manufacturer	Type/Model	CD Tag #	Firmware	Location	Comments/Notes	Status
	1JKCF1	DELL	Precision T3400	CD0001615471		Newport, OR Warehouse	Excess paperwork needs to be completed and hardrive drilled	Transferred
	2NP1PD1	DELL	Precision 490	CD0001615380		Newport, OR Warehouse	Excess paperwork needs to be completed and hardrive drilled	Transferred
	3JKCF1	DELL	Precision T3400	CD0001615472		F-06-002 (Server Room)	Re-purposed by CET for non-survey use	Transferred
	3M1PD1	DELL	Precision 490	CD0001615381		Newport, OR Warehouse	Excess paperwork needs to be completed and hardrive drilled	Transferred
	9MP1PD1	DELL	Precision 490	CD0001615385		Newport, OR Warehouse	Excess paperwork needs to be completed and hardrive drilled	Transferred
	JHKCF1	DELL	Precision T3400	CD0001615468		Newport, OR Warehouse	Excess paperwork needs to be completed and hardrive drilled	Transferred
	MP1PD1	DELL	Precision 490	CD0001615384		Newport, OR Warehouse	Excess paperwork needs to be completed and hardrive drilled	Transferred
10m Lead Line	10_01_05	FA Personnel	Traditional			NOAA Ship Fairweather S220	vfd for HSRR 2012	Lost
10m Lead Line	10_02_05	FA Personnel	Traditional			NOAA Ship Fairweather S220	vfd for HSRR 2012	OK
10m Lead Line	10_05_09	FA Personnel	V-100/Non-Traditiona			NOAA Ship Fairweather S220	vfd for HSRR 2011	OK
10m Lead Line	10_06_XX	FA Personnel	V-100/Non-Traditiona			NOAA Ship Fairweather S220	Not in service, still being completed.	OK
20m Lead Line	20_01_05	FA Personnel	Traditional			NOAA Ship Fairweather S220	vfd for HSRR 2012	Lost
20m Lead Line	20_02_05	FA Personnel	Traditional			NOAA Ship Fairweather S220	vfd for HSRR 2012	OK
20m Lead Line	20_03_05	FA Personnel	Traditional			NOAA Ship Fairweather S220	vfd for HSRR 2012	OK
2805-Acq	40001000160708	CYBERTRON	P4	VD0001703149		FA Launch 2805	Acq 2805- vfd for HSRR 2012	OK
2806- Acq	40001000160709	CYBERTRON	P4	CD0001703148		F-06-002 (Server Room)	Space Acq Machine (2806)	OK
2807- Acq	40001000160711	CYBERTRON	P4	CD0001703146		Plot 3	Spare Launch Acq Machine(2807)	OK
2808-Acq	40001000160707	CYBERTRON	P4	CD0001703147		FA Launch 2808	Acq 2808- vfd for HSRR 2012	OK
30m Lead Line	30_01_05	FA Personnel	Traditional			NOAA Ship Fairweather S220	vfd for HSRR 2012	OK
7111 Rx (EM7187)	1409093	Reson	7111 - Transducer			NOAA Ship Fairweather S220	Used Rx purchased from Reson and installed in 2012 drydock	OK
7111- TPU	2009003	Reson	7111 - TPU	CD0001065312		NOAA Ship Fairweather S220	vfd for HSRR 2012	OK
7111 Tranceiver Boards	3309001	Reson	7111 - Tranceiver			NOAA Ship Fairweather S220	In conference room- vfd HSRR 2012	Needs Service
7111 Tx (TC2126-3)	4608498	Reson	7111 - Transducer			NOAA Ship Fairweather S220	Used Tx purchased from Reson and installed in 2012 drydock	OK
7111 Wet End	5008001	Reson	7111 - Transducer			NOAA Ship Fairweather S220	Prepared to send back to Reson	Needs Service
7125- 200kHz TX	1008117	Reson	7125 - 200 Projector (2163)			CCOM/JHC (New Hampshire)	Returned to UNH for additional testing	On Loan
7125- 200kHz TX	2409098	Reson	7125 - 200 Projector (2163)			FA Launch 2808	vfd for HSRR 2012	OK
7125- 200kHz TX	4408351	Reson	7125 - 200 Projector (2163)			Manufacturer	Sent to Reson for evaluation/repair	Manf. Repair
7125- 200kHz TX	4408358	Reson	7125 - 200 Projector (2163)			C-02-001	Swapped for Calibrated UNH sonar and put in storage	OK
7125- 400kHz TX	1908209	Reson	7125 - 400 Projector (2160)			CCOM/JHC (New Hampshire)	Returned to UNH for additional testing	On Loan
7125- 400kHz TX	2208007	Reson	7125 - 400 Projector (2160)			FA Launch 2808	vfd for HSRR 2012	OK
7125- 400kHz TX	2308110	Reson	7125 - 400 Projector (2160)			Manufacturer	Sent to Reson for evaluation/repair	Manf. Repair
7125- 400kHz TX	4008071	Reson	7125 - 400 Projector (2160)			C-02-001	Swapped for Calibrated UNH sonar and put in storage	OK
7125- RX	0309014	Reson	7125 - Rx (EM7200)			CCOM/JHC (New Hampshire)	Returned to UNH for additional testing	On Loan
7125- Rx	3008265	Reson	7125 - Rx (EM7200)			C-02-001	Swapped for Calibrated UNH sonar and put in storage	OK
7125- RX	309012	Reson	7125 - Rx (EM7200)			FA Launch 2808	vfd for HSRR 2012	OK
7125- RX	309019	Reson	7125 - Rx (EM7200)			Manufacturer	Sent to Reson for evaluation/repair	Manf. Repair
7125- TPU	1812020	Reson	7125 - TPU	CD0001527818	7k UI: 3.12.5.8, 7k Center: 3.7.7.9, 7kIO: 3.4.1.11	CCOM/JHC (New Hampshire)	Returned to UNH for additional testing	On Loan
7125- TPU	1812023	Reson	7125 - TPU	CD0001529704	7k UI: 3.12.5.8, 7k Center: 3.7.7.9, 7kIO: 3.4.1.11	FA Launch 2808	vfd for HSRR 2012	OK
7125- TPU	1812027	Reson	7125 - TPU	CD0001529685	7k UI: 3.12.5.8, 7k Center: 3.7.7.9, 7kIO: 3.4.1.11	Manufacturer	Sent to Reson for evaluation/repair	Manf. Repair
7125- TPU	1812028	Reson	7125 - TPU	CD0001529714	7k UI: 3.12.5.8, 7k Center: 3.7.7.9, 7kIO: 3.4.1.11	C-02-001	Swapped for calibrated sonar from UNH	OK
8125- TPU	31562	Reson	8125 - TPU	CD0000825308	Dry: 8125-2.10-A50F, Wet: 8125-1.08-9E98	NOAA Ship Rainier S221	Txfred to RA for 2012 field season	On Loan
8125 Transducers	4400007	Reson	8125 - 455 Projector			NOAA Ship Rainier S221	Txfred to RA for 2012 field season	On Loan

8160- TPU	35385	Reson	8160 - TPU	CD0001065313	Dry: 8160-2,09-7C6D, Wet: 8160-1.00-E9E1	NOAA Ship Fairweather S220	vfd for HSRR 2012	OK
8160 Tranceiver Boards	35028	Reson	8160 - Tranceiver			NOAA Ship Fairweather S220	vfd for HSRR 2012	OK
8160 Wet End	FA-8160	Reson	8160 - Transducer			NOAA Ship Fairweather S220	vfd for HSRR 2012	OK
8-Port Gigabit Switch	RMQ00J700115	Lynksys	SRW2008	(P004421)		2806		OK
8-Port Gigabit Switch	RMQ00J700119	Lynksys	SRW2008	(P004424)		2808		OK
8-Port Gigabit Switch	RMQ00J700285	Lynksys	SRW2008	(P004422)		2805		OK
8-Port Gigabit Switch	RMQ00J70016	Lynksys	SRW2008			SPARE (C-02 STORES)		OK
ACQ-1	CSH8FN1	DELL	Precision T3400	CD0001615444		Plot 1	Acq1- vfd for HSRR 2012	OK
Acq-2	HG7CWK1	DELL	Precision T3400	CD0001766763		Plot 1	Perminately re-purposed as Acq2 and relocated to acq station.	OK
Antenna cable	XXX4	Trimble						OK
Bay Hydro 5410	260	Klein	5410 - Towfish			NOAA Ship Fairweather S220	vfd for HSRR 2012	OK
Camcorder Batteries	XXX5	Trimble						OK
CST	DJKBZK1	DELL	Precision T3400	CD0001766913		Plot 1	Now used as CST computer	OK
data/power cable 1	XXX7	Trimble						OK
DGPS Antenna	0328-12352-0002	CSI Wireless	MGL3			Matrix		OK
DGPS Antenna	0919-9231-0191	Hemisphere	MA40			C-02-001	SPARE (C-02 STORES)	OK
DGPS Antenna	0919-9231-0193	Hemisphere	MA40			C-02-001	SPARE (C-02 STORES) (2806)	OK
DGPS Antenna	0924-9488-0040	Hemisphere	MA40			FA Launch 2808		OK
DGPS Antenna	0924-9488-0046	Hemisphere	MA40			FA Launch 2805		OK
DGPS Antenna	220395038	Trimble	33580-00 ?			CO2		OK
DGPS Antenna	9824-1779-0002	CSI Wireless	MGL3			NOAA Ship Fairweather S220		OK
DGPS Receiver	0324-11969-0002	CSI Wireless	MBX-3S	CD0001065375	P012-0.1-Bx	NOAA Ship Fairweather S220		OK
DGPS Receiver	0328-12362-0001	CSI Wireless	MBX-3S	10652291		D-02-001 (ET Stores)		OK
DGPS Receiver	0923-9416-0005	Hemisphere	MBX-4	CD0001709329	P012-0.010-Bx	C-02-001	SPARE (C-02 STORES) (2806)	OK
DGPS Receiver	0923-9416-0007	Hemisphere	MBX-4		P012-0.010-Bx	C-02-001	SPARE (C-02 STORES)	OK
DGPS Receiver	0924-9498-000	Hemisphere	MBX-4		P012-0.010-Bx	FA Launch 2808		OK
DGPS Receiver	0927-9567-0001	Hemisphere	MBX-4	CD0001709331	P012-0.010-Bx	FA Launch 2805		OK
Digibar Pro	98207	Odorn Hydrographic Systems	DB 1200	A009511	SW 1.11			OK
Divers Least Depth Gauge	68337	PTC	MODIII	CD0001698256		F-05-002 (ET Shop)	Having issues	Needs Service
Divers Least Depth Gauge	DT15894	RJE International Inc.	TAC-DDGC-III	P004373		Plot 3	New unit, but part needed	OK
Divers Least Depth Gauge	DT16313	RJE International Inc.	TAC-DDGC-III	P004372		Plot 3	In service	OK
dual battery cable 2	XXX8	Trimble						OK
FOO	7G7CWK1	DELL	Precision T3400	CD0001766754		Plot 1	Now used as FOO computer	OK
GPS Antenna	12297641	Trimble	Zephyr Geodetic			CO2		OK
GPS Antenna	13843.531	NovAtel	531			ET Stores D2		OK
GPS Antenna	1441027807	Trimble	Zephyr Geodetic 2			field or O-lab		OK
GPS Antenna	1441031361	Trimble	Zephyr Geodetic 2			field or O-lab		OK
GPS Antenna	18250.531	NovAtel	531			ET Stores D2		OK
GPS Antenna	18284.531	NovAtel	531			ET Stores D2		OK
GPS Antenna	220298707	Trimble	Trimble Micro Centered L1/L2	(NOAA Launch Barcode A20)		CO2		OK
GPS Antenna	30325441	Trimble	Zephyr Geodetic 2			CO2		OK
GPS Antenna	30767996	Trimble	Zephyr Geodetic 2			field or O-lab		OK
GPS Antenna	5876	Trimble	SPS MSK			CO2		OK
GPS Antenna	8365	Ashtech	Geodetic 4			field or O-lab		OK
GPS Pathfinder field device cable	XXX9	Trimble				C-02-001 (FWD Survey Stores)	with GPS Pathfinder	OK
GPS Receiver	225111655	Trimble	DSM-232RS	CD0001697422		CO2		OK
GPS Receiver	ZE1200339016	Ashtech	Z-Xtreme	CD0001062363		field or O-lab		OK
GPS Receiver	4910K61054	Trimble	NetR5	CD0001526973		field or O-lab		OK
GPS Receiver	5034K69677	Trimble	NetR9	CD0001709320		field or O-lab		OK
GPS Receiver	5034K69698	Trimble	NetR9	CD0001709319		field or O-lab		OK
GPS RTK Receiver	225111661	Trimble	DSM-232	CD0001697439		CO2		OK
GPS RTK Reciver	220339262	Trimble	MS 750	CD0001478898		CO2		OK
Handheld data collector	37318	Trimble	TSCe			S220 O-lab, Backpack		OK
Hard Drive Dock 1	XXX10	Nexstar						OK
Hard Drive Dock 2	XXX11	Nexstar						OK
Hard Drive Dock 3	XXX12	Nexstar						OK
Hard Drive Dock 4	XXX13	Nexstar						OK
Hassler Heavyweight K5K	244	Klein	5000 - Towfish			NOAA Ship Fairweather S220	Transferred to FA	OK
Heavyweight K5K	293	Klein	5000 - Towfish	CD0000825404		NOAA Ship Fairweather S220	placed in operation on fantail of ship	OK
K5K- TPU	117633	Klein	5000 - TPU	CD0001527021		FA Launch 2805	Installed for Arctic Project 2011	OK
K5K- TPU	119307	Klein	5000 - TPU	CD0001709343		NOAA Ship Fairweather S220	vfd for HSRR 2012	OK
K5K- TPU	130144	Klein	5000 - TPU	CD0001527022		NOAA Ship Fairweather S220	Installed in Dive Lab	OK
K5K- TPU	Hassler-TPU	Klein	5000 - TPU	CD0001722042		C-11-001 (AFT Survey Stores)	Transferred to FA	OK
Laser	000676	Laser Tech Inc.	TruPulse 200 Laser Rangefinder			field or O-lab		OK

Laser	001481	Laser Tech Inc.	TruPulse 200 Laser Rangefinder			field or O-lab		OK
Laser	041156	Laser Tech Inc.	TruPulse 200 Laser Rangefinder			field or O-lab		OK
Laser	041169	Laser Tech Inc.	TruPulse 200 Laser Rangefinder			field or O-lab		OK
Laser	i09290	Laser Tech Inc.	Impulse Laser Rangefinder	CD0001269812		field or O-lab		OK
Level	100056	Carl Zeiss	N12 333			O-Lab		OK
Level	103267	Carl Zeiss	N12 333			O-Lab	vfd for HSRR 2012	OK
Level	5332739	Leica	NA2 100			stored in O-lab		OK
Level	5332747	Leica	NA2 100			stored in O-lab		OK
Lightweight KSK	321	Klein	5000 - Towfish			NOAA Ship Fairweather S220	vfd in HSRR 2012	OK
Micro Thermosalinograph	4536628-0117	Sea-Bird	SBE 45 (TSG)			Lodar room		OK
MVP- Fish	10329	Brooke Ocean Technology Inc.	MVP-FFF-SS-32-1			NOAA Ship Fairweather S220	spare- vfd for HSRR 2012	OK
MVP- Fish	10478	Brooke Ocean Technology Inc.	MVP-FFF-SS-32-1			NOAA Ship Fairweather S220	Current Fish in Use	OK
MVP- Fish Sensor	4986	Applied Micro Systems Ltd.	AML Smart SV +P			NOAA Ship Fairweather S220	Installed on fish- In Use	OK
MVP- Fish Sensor	5229	Applied Micro Systems Ltd.	AML Smart SV +P			NOAA Ship Fairweather S220	In use in MVP.	OK
MVP- Fish Sensor	5466	Applied Micro Systems Ltd.	AML Smart SV +P			NOAA Ship Ferdinand Hassler S250		OK
MVP-200	10328	Brooke Ocean Technology Inc.	MVP-C1-2001			NOAA Ship Fairweather S220	New system install in MRP	OK
MVP-200	10330	ODOM Brooke Ocean	MVP-C1-2001	CD0001269854		Plot 1	vfd for HSRR 2012	Needs Service
NMEA/RTCM cable	XXX6	Trimble						OK
ODOM Echotrac CVM	26034	ODOM Hydrographic Systems	Echotrac CVM-A	CD0001703210		O-Lab	vfd for HSRR 2012	OK
O-Lab	1H7CWX1	DELL	Precision T3400	CD0001766765		O-Lab	Now used for O-lab computer.	OK
P1	GV1ZSR1	DELL	Precision T3500	CD0001775172		Plot 1	New computer put into service as P1	OK
P2	GV1SSR1	DELL	Precision T3500	CD0001775170		Plot 1	New computer put into service as P2	OK
P3	GV1VSR1	DELL	Precision T3500	CD0001775165		Plot 1	New computer put into service as P3	OK
P4	3MD5KN1	DELL	Precision T3500	CD0001684477		Plot 1	P4- vfd for HSRR 2012	OK
P5	5N54KN1	DELL	Precision T3500	CD0001684476		Plot 1	P5- vfd for HSRR 2012	OK
P6	GV1RSR1	DELL	Precision T3500	CD0001775166		Plot 1	New computer put into service as P6	OK
P6/Proc4-P3	JG7CWX1	DELL	Precision T3400	CD0001766764		F-06-002 (Server Room)	P6- to be renamed and moved to DP3 after Fishpac	OK
P7	3MD4KN1	DELL	Precision T3500	CD0001684478		Plot 1	P7- vfd for HSRR 2012	OK
P8	GV1YSR1	DELL	Precision T3500	CD0001775171		Plot 1	New computer put into service as P8	OK
P8/Proc3-P3	GZ55ZK1	DELL	Precision T3400	CD0001766791		F-06-002 (Server Room)	P8- to be renamed and moved to DP3 after Fishpac	OK
P9	GV23TR1	DELL	Precision T3500	CD0001775169		Plot 1	New computer put into service as P9	OK
Penetrometer	10416	Brooke Ocean Technology Inc.	FFCPT-35-2			Not found on FA	Kept at WRC by FishPac	OK
Penetrometer sensor	191-3	Brooke Ocean Technology Inc.	AML SV +P			Not found on FA	Kept at WRC by FishPac	OK
POS MV Antenna	60145158	Trimble	OEM2 3151R			Matrix		OK
POS MV Antenna	60268090	Timble	OEM2 3151R			Matrix		OK
POS MV IMU	007	Applanix		CD00001709318		ET stores D02		OK
POS MV IMU	037	Applanix	LN200	CD0000832907		C-02-001	Spare for 2012 Field Season	OK
POS MV IMU	047	Applanix	LN200	CD0000825306		FOO stores		OK
POS MV IMU	292	Applanix	LN200	CD0001696450		NOAA Ship Fairweather S220	New System Install	OK
POS MV IMU	294	Applanix	LN200	CD0001696449		FA Launch 2805	Installed on New launch	OK
POS MV IMU	323	Applanix	LN200			FOO stores		OK
POS MV IMU	324	Applanix	LN200	CD0001722041		C-02-001	Spare for 2012 Field Season	OK
POS MV IMU	991	Applanix	LN200	CD0001722214		FA Launch 2808	vfd for HSRR 2012	OK
POS MV IMU	995	Applanix	LN200	CD0001530026		FOO Stores		OK
POS MV PCS (V4)	2411	Applanix	POS-MV 320 v4	CD0001697462		FA Launch 2808	vfd for HSRR 2012	OK
POS MV PCS (V4)	2560	Applanix	POS-MV 320 v4	CD0001601274	HW2.6-7, SW04.22, POS Cntrlr v. 4.3.4.0	FA Launch 2808	Upgraded to internal logging and moved.	OK
POS MV PCS (V4)	2564	Applanix	POS-MV 320 v4	CD0001601275	HW2.6-7, SW04.22, POS Cntrlr v. 4.3.4.0	C-02-001	Spare for 2012 Field Season	OK
POS MV PCS (V4)	3627	Applanix	POS-MV 320 v4	CD0001527797	HW4.1-7, SW04.22, POS Cntrlr v. 4.3.4.0	NOAA Ship Fairweather S220	WAAS Cabable. No internal logging.	OK
POS MV PCS (V4)	3628	Applanix	POS-MV 320 v4	CD0001527796	HW4.1-7, SW05.01, POS Cntrlr v. 5.1.0.2	FA Launch 2805	Upgraded to internal logging. Moved to launch.	OK
POS MV Port Antenna	1440904133	Trimble	Zephyr II			NOAA Ship Fairweather S220	New Equipment Install	OK
POS MV Port Antenna	1440904832	Trimble	Zephyr II			FA Launch 2808		OK
POS MV Port Antenna	1440925095	Trimble	Zephyr II			C-02-001	Spare for 2012 Field Season	OK
POS MV Port Antenna	31171727	Trimble	Zephyr II			FA Launch 2805	New System Install	OK
POS MV Port Antenna	60078644	Trimble	Zephyr I			C-02-001	Spare for 2012 Field Season	OK
POS MV Stbd Antenna	1440912566	Trimble	Zephyr II			C-02-001	Spare for 2012 Field Season	OK
POS MV Stbd Antenna	1440941041	Trimble	Zephyr II			FA Launch 2808		OK
POS MV Stbd Antenna	31180200	Trimble	Zephyr II			NOAA Ship Fairweather S220	New Equipment Install	OK
POS MV Stbd Antenna	31185275	Trimble	Zephyr II			FA Launch 2805	New System Install	OK

POS MV Stbd Antenna	60125191	Trimble	Zephyr I			C-02-001	Spare for 2012 Field Season	OK
POS MV Stbd Antenna	60130644	Trimble	Zephyr I			Unknown	Failure. Removed from service	Transferred
Position Data Link High Powered Base Unit	0424 0171	Pacific Crest	PDL 4135	CD0001269910		C02		OK
Position Data Link Rover	03473047	Pacific Crest	PDL 4100	CD0001269912		C02		OK
Position Data Link Rover	04240154	Pacific Crest	PDL 4100	CD0001269896		C02		OK
Position Data Link Rover	04240155	Pacific Crest	PDL 4100	CD0001269911		C02		OK
Position Data Link Rover	07095939	Pacific Crest	PDL 4101			C02		OK
Proc1-P2	DHKCZF1	DELL	Precision T3400	CD0001615470		Plot 2	Proc1-P2- relocated from FOO desk	OK
Proc1-P3	FJKBZK1	DELL	Precision T3400	CD0001766914		Plot 3	Proc1-P3- vfd for HSRR 2012	OK
Proc2-P2?	HZ55HK1	DELL	Precision T3400	CD0001766792				OK
SBES Transducer	TR5138	ODOM Hydrographic Systems	SMBB200_9			O-Lab	Purchased	OK
SBES Transducer	TR5139	ODOM Hydrographic Systems	SMBB200_9			O-Lab	Purchased	OK
SBES Transducer	TR5159	ODOM Hydrographic Systems	SMBB200_4A			O-Lab	Purchased	OK
SBES Transducer	TR5162	ODOM Hydrographic Systems	SMBB200_4A			O-Lab	Purchased	OK
SEACAT Profiler	19P36026-4585	Sea-Bird	SBE 19plus	CD0001697254	1.6b	NOAA Ship Fairweather S220	vfd for HSRR 2012	OK
SEACAT Profiler	19P36026-4616	Sea-Bird	SBE 19plus	CD0001697264	1.6b	Unknown	CTD Lost during wreck seach in Newport, OR	Lost
SEACAT Profiler	19P36026-4617	Sea-bird	SBE 19plus	CD0001697251	1.6b	NOAA Ship Fairweather S220	vfd for HSRR 2012 for launch use	OK
SEACAT Profiler	19P50959-6121	Sea-bird	SBE 19plus V2	CD0001527777	2.3	NOAA Ship Fairweather S220	vfd for HSRR 2012 for launch use	OK
SEACAT Profiler	19P50959-6122	Sea-bird	SBE 19plus V2	CD0001527778	2.2c	C-02-001	vfd for HSRR 2012- In storage for use in 2013	OK
Solar Charger	0702EPRC5-026	PWM	EPRC5			stored O-lab		OK
Solar Charger	10190177	Morningstar	SS-10-L. 12v			field or O-lab		OK
Solar Charger	10190178	Morningstar	SS-10-L. 12v			field or O-lab		OK
Solar Charger	10190179	Morningstar	SS-10-L. 12v			field or O-lab		OK
Solar Charger	10331024	Morningstar	SS-10-L. 12v			field or O-lab		OK
Solar Charger 1	XXX1	PWM	EPRC5		323	SPARE (C-02 STORES)		OK
Solar Charger 2	XXX2	PWM	EPRC5					OK
Solar Panel	146624	Sunlinq	P3-12V-60			field or O-lab		OK
Solar Panel	146636	Sunlinq	P3-12V-60			field or O-lab		OK
Solar Panel	525-011093	Uni-Solar	MBC-525	CD000684507		field or O-lab		OK
Solar Panel	525-011589	Uni-Solar	MBC-525	CD000684510		field or O-lab		OK
Solar Panel	525-011607	Uni-Solar	MBC-525	CD000684512		field or O-lab		OK
Solar Panel	C30G200506210063	GE Energy	GEPV-030-MNA-001			stored O-lab		OK
Solar Panel	USF-32-14529	Uni-Solar	FLX-32			field or O-lab		OK
Solar Panel	USF-32-14625	Uni-Solar	FLX-32			field or O-lab		OK
Solar Panel	USF-32-14631	Uni-Solar	FLX-32			field or O-lab		OK
Solar Panel	USF-32-14633	Uni-Solar	FLX-32			field or O-lab		OK
Solar Panel	USF-32-14634	Uni-Solar	FLX-32			field or O-lab		OK
Solar Panel	USF-32-14639	Uni-Solar	FLX-32			field or O-lab		OK
Solutions Dongles	KEB2077	Ashtech	600586 (A)			missing		OK
Solutions Dongles	KEB2083	Ashtech	600586 (A)			CST desk		OK
StarFire GPS Antenna	7020	NavCom	AN-2004T				ocation entry C02	OK
StarFire GPS Receiver	5012	NavCom	SF-2050R	CD0001697402		Plot 1		OK
StarFire GPS Receiver	5086	NavCom	SF-2050G	CD0001699203			Location entry C02	OK
SVP- 70	4008077	Reson	SVP-70			NOAA Ship Fairweather S220	New system install	Needs Service
SVP- 70	4111053	Reson	SVP-70			Plot 1	Fleet Spare received for backup	
SVP- 71	2008017	Reson	SVP-71			FA Launch 2808	New system install	OK
SVP-71	2008016	Reson	SVP-71			F-05-002 (ET Shop)	Spare	OK
SVP-71	2008024	Reson	SVP-71			FA Launch 2805	New system install	OK
SVP-71	2008038	Reson	SVP-71	CD0001776104		F-05-002 (ET Shop)	Spare	OK
Trimble Backpack 1	0224078543	Trimble	Pathfinder Pro XRS	CD0001269835	Firmware v1.96 RevA	O-Lab	Can be on the Field	OK
Trimble Backpack 1: Antenna	0220341062	Trimble	33580-50			field or O-lab		OK
Trimble Backpack 2	0224090101	Timble	Pathfinder Pro XRS	CD0001269836	Firmware v1.96 RevA	field or O-lab		OK
Trimble Backpack 2: Antenna	0220321059	Timble	33580-50			field or O-lab		OK
UHF Antenna	N/A	PCTEL	MAX9053			S220		OK
UHF Radio	884-9190	FreeWave	HTP-900RE	CD0001526971		S220		OK
UHF Radio	884-9301	FreeWave	HTP-900RE	(P004369)		2808		OK
UHF Radio	884-9511	FreeWave	HTP-900RE	(P004370)		field or O-lab		OK
UHF Radio	885-8156	FreeWave	HTP-900RE	CD0001709328		SPARE (C-02 STORES) (2806)		OK
UHF Radio	885-8689	FreeWave	HTP-900RE			SPARE (C-02 STORES) (2807)		OK
UHF Radio	885-8740	FreeWave	HTP-900RE	CD0001709330		2805		OK
UHF Radio	886-0744	FreeWave	HTP-900RE	CD0001526976		field or O-lab		OK
UHF Radio	886-0745	FreeWave	HTP-900RE	CD0001526975		field or O-lab		OK
UHF Radio	XXX3	PCTEL	MAX9053					OK

FAIRWEATHER Survey Computers

Machine Name	Location	Make/Model	Operating System	Date Purchased	Year to Be Replaced	Date of Last Rebuild	Processor Speed	RAM (original)	RAM (checked date)	Number of Video Outputs	Video RAM	Service Tag	Barcode	Comments	STATUS 11/29/2012
FA-Proc1	Plot Room				2016										Mission- In Use
FA-Proc2	Plot Room				2016										Mission- In Use
FA-Proc3	Plot Room				2016										Mission- In Use
FA-Proc4	Plot Room	Dell Precision T3500	Win 7 Pro	Winter 2011	2015		3.33 GHz	12 GB		2	3MD5KN1	CD0001684477	Windows 7 64 Bit		Mission- In Use
FA-Proc5	Plot Room	Dell Precision T3500	Win 7 Pro	Winter 2011	2015		3.33 GHz	12 GB		2	5N55KN1	CD0001684476	Windows 7 64 Bit		Mission- In Use
FA-Proc6	Plot Room				2016										Mission- In Use
FA-Proc7	Plot Room	Dell Precision T3500	Win 7 Pro	Winter 2011	2015		3.33 GHz	12 GB		2	3MD4KN1	CD0001684478	Windows 7 64 Bit		Mission- In Use
FA-Proc8	Plot Room				2016										Mission- In Use
FA-Proc9	Plot Room				2016										Mission- In Use
FA-CST	Field Office	Dell Precision T3400	XP Pro 2002 SP3	Summer 2010	2014		3.33 GHz	3 GB		2	512 MB	DJKBZK1	CD0001766913	Moved from FA-Proc2 5/2012- Not Refreshed by OCS, but EEB	Non-Mission In Use
FA-FOO	Field Office	Dell Precision T3400	XP Pro 2002 SP3	Summer 2010	2014		3.33 GHz	3 GB		2	512 MB	7G7CWX1	CD0001766754	Moved from FA-Proc3 5/2012- Not Refreshed by OCS, But EEB	Non-Mission In Use
FA-OLab	O-Lab	Dell Precision T3400	XP Pro 2002 SP3	Spring 2008?	-	-	3.0 GHz	3 GB		2	512 MB	4JKCZF1	CD0001615469	Moved from FA-CST 5/2012- Unsupported by EEB	In Use
FA_P2_Proc1	Plot Room 2	Dell Precision T3400	XP Pro 2002 SP3	Spring 2008?	-	-	3.0 GHz	3 GB		2	512 MB	4JKCZF1	CD0001615470	Moved from FA-FOO 5/2012- Unsupported by EEB	In Use
FA_P3_Proc1	Plot Room 3	Dell Precision T3400	XP Pro 2002 SP3	Summer-09	2013		3.33 GHz	3 GB		2	512 MB	FJKBZK1	CD0001766914		Mission- In Use
FA_P3_Proc2	Plot Room 3	Dell Precision T3400	XP Pro 2002 SP3	Summer-09	2013		3.33 GHz	3 GB		2	512 MB	JG7CWX1	CD0001766764	Moved from FA-Proc6 5/12	Mission-Storage
FA_P3_Proc3	Plot Room 3	Dell Precision T3400	XP Pro 2002 SP3	Summer-09	2013		3.33 GHz	3 GB		2	512 MB	GZ55K1	CD0001766791	Moved from FA-Proc8 5/12	Mission-Storage
FA_P3_Proc4	Plot Room 3	Dell Precision T3400	XP Pro 2002 SP3	Summer-09	2013		3.33 GHz	3 GB		2	512 MB	HZ55ZK1	CD0001766792		Mission- In Use
Toughbook 1	ET Office	Panasonic CF-18	XP Pro 2002 SP2	~ March 2004	-	~ July 2006	1.1 GHz	2.5 GB		1	64 MB	4HKSAS9499	CD0001269860	ET Office	Not For Survey
Toughbook 2	Laptop	Panasonic CF-18	XP Pro 2002 SP2	~ March 2004	-	~ September 2007	1.1 GHz	2.5 GB		1	64 MB	4HKSAS9560	CD0001269858	Tides ToughBook- In disrepair	In Use
Toughbook 3	Laptop	Panasonic CF-29	XP Pro 2002 SP2	March 2006	-		1.6 GHz	2.5 GB		1	128 MB	6AKSB06863	CD0001698251	In Need of Replacement	In Use
Toughbook 4	Laptop	Panasonic CF-30	XP Pro 2002 SP3	March 2009	-		1.7 GHz	1 Gb		0	384 MB	8HKSB80630	CD0001447100		In Use
Toughbook 6	Laptop	Panasonic CF-30	XP Pro 2002 SP3	March 2009	-		1.7 GHz	1 Gb		0	384 MB	8HKSB80631	CD0001447101		In Use
Toughbook 5	Laptop	Panasonic CF-19	XP Pro 2002 SP3	March 2009	-		1.1 GHz	1 Gb		1	384 MB	9AKSB43281	CD0001696424		In Use
Survey Mobile Workstation	Laptop	Dell Precision M4400	XP Pro 2002 SP3				3.0 GHz	3.5 Gb		1	512 MB	8L56ZK1	CD0001766841		In Use
2805_ACQ	Launch 2805	Cybertron PC ACP-4000	XP Pro 2002 SP3		2014		2.0 GHz	3 GB		2	1024 MB	40001000160709	CD0001703148	P/N ACP-4000MB-00XE	In Use
2806_ACQ	Launch 2806	Cybertron PC ACP-4000	XP Pro 2002 SP3		2014		2.0 GHz	3 GB		2	1024 MB	40001000160707	CD0001703147	P/N ACP-4000MB-00XE	Storage
2807_ACQ	Launch 2807?	Cybertron PC ACP-4000	XP Pro 2002 SP3		2014		2.0 GHz	3 GB		2	1024 MB	40001000160711	CD0001703146	P/N ACP-4000MB-00XE	Storage
2808_ACQ	Launch 2808	Cybertron PC ACP-4000	XP Pro 2002 SP3		2014		2.0 GHz	3 GB		2	1024 MB	40001000160708	CD0001703149	P/N ACP-4000MB-00XE	In Use
S220_ACQ	Plot Room	Dell Precision T3400	XP Pro 2002 SP2	Mar-08	2012		3.0 GHz	3 GB		3	512 MB	CSH8NF1	CD0001615444	Overdue for Replacement	In Use
S220_ACQ2	Plot Room	Dell Precision T3400	XP Pro 2002 SP3	Summer-09	2013		3.33 GHz	3 GB		2	512 MB	HG7LWK1	CD0001766763	New Dell desktop installed March 2010	In Use
FA_MVP200	Plot Room	MVP-C1-2001	2000 SP4	~ March 2004	-	~ May 2012	2.4 GHz	230 MB		1	64 MB	SN: 10330	CD0001269854		In Use

Old Work Stations Removed May 2012

FA-Proc9	Plot Room	Dell Precision T3400	XP Pro 2002 SP3	Apr-08	Removed 2012		3.0 GHz	3 GB		2	512 MB	3JKCZF1	CD0001615472	Dell desktop installed week of 04/06/08	Removed
FA_Proc_10	Plot Room	Dell Precision T3400	XP Pro 2002 SP3	Apr-08	Removed 2012		3.0 GHz	3 GB		2	512 MB	TJKCZF1	CD0001615471	04/06/08, Not installed as of 6/3/10	Removed
FA-OLab	O-Lab	Dell Precision 490	XP Pro 2002 SP3	Nov-07	Removed 2012		2.66 GHz	3 GB		2	256 MB	2NP1PD1	CD0001615380	Dell desktop installed week of 12/4/07, Moved 03/2010	Removed
FA_P2_Proc1	Plot Room 2	Dell Precision T3400	XP Pro 2002 SP3	Apr-08	Removed 2012		3.0 GHz	3 GB		2	512 MB	JHKCZF1	CD0001615468	Dell desktop installed week of 04/06/08	Removed
FA_P3_Proc2	Plot Room 3	Dell Precision 490	XP Pro 2002 SP3	Nov-07	Removed 2012		2.66 GHz	3 GB		2	256 MB	8MP1PD1	CD0001615384	Dell desktop installed week of 12/4/07, Moved 03/2010	Removed
FA_P3_Proc3	Plot Room 3	Dell Precision 490	XP Pro 2002 SP3	Nov-07	Removed 2012		2.66 GHz	3 GB		2	256 MB	9MP1PD1	CD0001615385	Refreshed 02/2010, 12/4/07, Moved 03/2010	Removed



Certificate of Calibration

Customer:
Asset Serial Number:
Asset Product Type:
Calibration Type:
Calibration Range:
Calibration RMS Error:
Calibration ID:
Installed On:

Coefficient A:	Coefficient G:
Coefficient B:	Coefficient H:
Coefficient C:	Coefficient I:
Coefficient D:	Coefficient J:
Coefficient E:	Coefficient K:
Coefficient F:	Coefficient L:
	Coefficient M:

Calibration Date (dd/mm/yyyy):
Certified By:

A handwritten signature in black ink, which appears to read 'Robert Haydock', is written over a faint, semi-transparent watermark of the AML Oceanographic logo.

Robert Haydock
President, AML Oceanographic

AML Oceanographic certifies that the asset described above has been calibrated or recalibrated with equipment referenced to traceable standards. Please note that Xchange™ sensor-heads may be installed on assets other than the one listed above; this calibration certificate will still be valid when used on other such assets. If this instrument or sensor has been recalibrated, please be sure to update your records. Please also ensure that you update the instrument's coefficient values in any post-processing software that you use, if necessary. Older generation instruments may require configuration files, which are available for download at our Customer Centre at www.AMLoceanographic.com/support



Certificate of Calibration

Customer: NOAA - Pacific Marine Center
Asset Serial Number: 004986
Asset Product Type: Smart SV&P for Brooke MVP -
Calibration Type: Sound Velocity
Calibration Range: 1400 to 1550 m/s
Calibration RMS Error: .0221
Calibration ID: 004986 999999 S00379 050112 213258
Installed On:

Coefficient A:	1.521097E+3	Coefficient G:	0.000000E+0
Coefficient B:	-1.067196E+2	Coefficient H:	0.000000E+0
Coefficient C:	8.855808E+0	Coefficient I:	0.000000E+0
Coefficient D:	-1.015399E+0	Coefficient J:	0.000000E+0
Coefficient E:	0.000000E+0	Coefficient K:	0.000000E+0
Coefficient F:	0.000000E+0	Coefficient L:	0.000000E+0
		Coefficient M:	0.000000E+0

Calibration Date (dd/mm/yyyy): 5/1/2012
Certified By:

Robert Haydock
President, AML Oceanographic

AML Oceanographic certifies that the asset described above has been calibrated or recalibrated with equipment referenced to traceable standards. Please note that Xchange™ sensor-heads may be installed on assets other than the one listed above; this calibration certificate will still be valid when used on other such assets. If this instrument or sensor has been recalibrated, please be sure to update your records. Please also ensure that you update the instrument's coefficient values in any post-processing software that you use, if necessary. Older generation instruments may require configuration files, which are available for download at our Customer Centre at www.AMLoceanographic.com/support



Certificate of Calibration

005229

Customer: NOAA - Pacific Marine Center

Asset Serial Number: 005229

Asset Type: 005229 (Smart SV&P)

Calibrated Pressure Range: 1000 dBar

Certification Date: 07/01/2010 (dd/mm/yyyy)

Certified By:

A handwritten signature in blue ink, which appears to read 'Robert Haydock', is written over a faint, light blue watermark of the AML Oceanographic logo.

Robert Haydock,
President
AML Oceanographic

AML Oceanographic certifies that the equipment described above has been calibrated with equipment referenced to traceable standards. Any repairs / calibrations completed on this instrument were approved by the instrument owner under purchase order.

This instrument has been recalibrated. Please be sure to update your records. Please also ensure that you update the instrument's coefficient values in any post-processing software (ie. Smart Talk) that you use. Instrument configuration files are available at our Client Service & Support Portal (see web address below).

For a complete service history of this instrument, please consult our on-line Client Service & Support Portal at <http://www.AMLoceanographic.com/customers/index.htm>

Pressure Calibration

Date 01/07/10
S/N 005229
Calibrator Wanda Turple
RMS Error 0.070
Range 1000 dBar

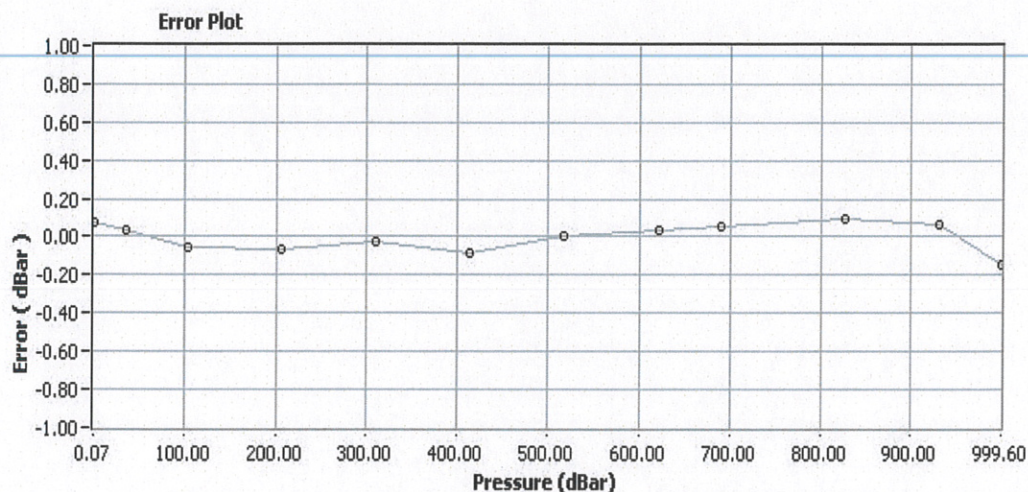

$$dBar=A+B*T+C*T^2+D*T^3+(E+F*T+G*T^2+H*T^3)*Raw+(I+J*T+K*T^2+L*T^3)*Raw^2$$

A=-1.578327E+3	G=-1.166428E-6
B=-1.070159E+0	H=6.284819E-9
C=3.082572E-2	I=5.421774E-8
D=-1.663931E-4	J=-4.048055E-10
E=4.829603E-2	K=9.376432E-12
F=4.819032E-5	L=-7.653517E-14



2071 Malaview Ave West, Sidney, British Columbia, Canada V8L 5X6
Phone: (250) 656-0771 Fax: (250) 655-3655
Canada & USA: 800-663-8721
Email: info@amloceanographic.com Web: <http://www.amloceanographic.com>

Sound Velocity Calibration

Date 01/07/10
S/N 005229
Calibrator Wanda Turple
RMS Error 0.019
Range 1400 to 1550 m/s

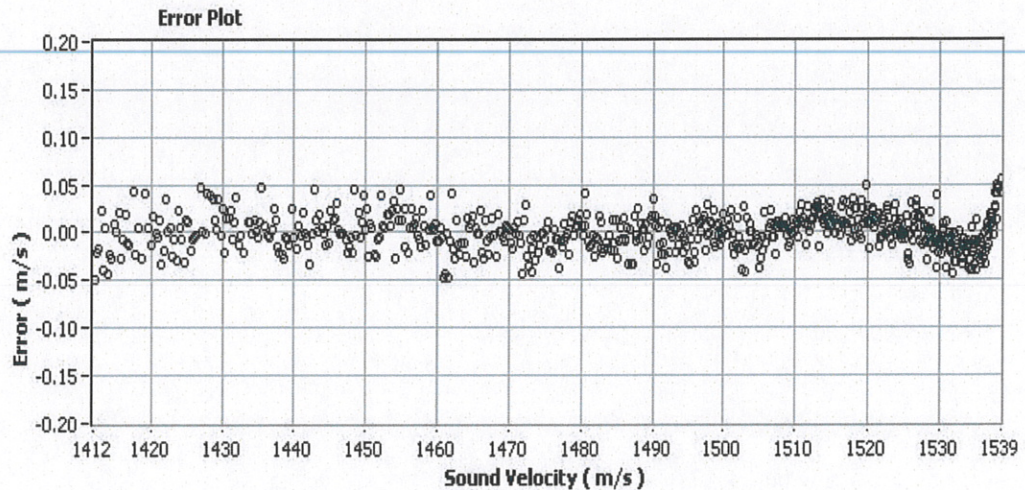

$$m/s = A + B * ((NH - N) / (NH - NL)) + C * ((NH - N) / (NH - NL))^2 + D * ((NH - N) / (NH - NL))^3$$

A=1.535705E+3	G=0.000000E+00
B=-1.134026E+2	H=0.000000E+00
C=9.583656E+0	I=0.000000E+00
D=-9.826408E-1	J=0.000000E+00
E=0.000000E+00	K=0.000000E+00
F=0.000000E+00	L=0.000000E+00



2071 Malaview Ave West, Sidney, British Columbia, Canada V8L 5X6
Phone: (250) 656-0771 Fax: (250) 655-3655
Canada & USA: 800-663-8721
Email: info@amloceanographic.com Web: <http://www.amloceanographic.com>



Certificate of Calibration

Customer: NOAA - Pacific Marine Center
Asset Serial Number: 005466
Asset Product Type: Smart SV&P for Brooke MVP - PDC-A0200-OEM-Brooke
Calibration Type: Pressure
Calibration Range: 1000 dBar
Calibration RMS Error: .0363
Calibration ID: 005466 999999 0UE855 221210 181408
Installed On:

Coefficient A:	-1.239801E+3	Coefficient G:	-1.128182E-6
Coefficient B:	-3.145002E-1	Coefficient H:	1.415759E-8
Coefficient C:	3.012141E-2	Coefficient I:	-5.470870E-9
Coefficient D:	-3.571170E-4	Coefficient J:	-1.925685E-10
Coefficient E:	4.406489E-2	Coefficient K:	1.080000E-11
Coefficient F:	2.278661E-5	Coefficient L:	-1.832266E-13
		Coefficient M:	

Calibration Date: 22/12/2010
Certified By:

Robert Haydock
President, AML Oceanographic

AML Oceanographic certifies that the asset described above has been calibrated or recalibrated with equipment referenced to traceable standards. Please note that Xchange™ sensor-heads may be installed on assets other than the one listed above; this calibration certificate will still be valid when used on other such assets. If this instrument or sensor has been recalibrated, please be sure to update your records. Please also ensure that you update the instrument's coefficient values in any post-processing software that you use, if necessary. Older generation instruments may require configuration files, which are available for download at our Customer Centre at www.AMLoceanographic.com/support



Certificate of Calibration

Customer: NOAA - Pacific Marine Center
 Asset Serial Number: 005466
 Asset Product Type: Smart SV&P for Brooke MVP - PDC-A0200-OEM-Brooke
 Calibration Type: Sound Velocity
 Calibration Range: 1400 to 1550 m/s
 Calibration RMS Error: .0202
 Calibration ID: 005466 999999 140294 141210 195516
 Installed On:

Coefficient A:	1.534096E+3	Coefficient G:	0.000000E+0
Coefficient B:	-1.129699E+2	Coefficient H:	0.000000E+0
Coefficient C:	9.133756E+0	Coefficient I:	0.000000E+0
Coefficient D:	-7.934285E-1	Coefficient J:	0.000000E+0
Coefficient E:	0.000000E+0	Coefficient K:	0.000000E+0
Coefficient F:	0.000000E+0	Coefficient L:	0.000000E+0
		Coefficient M:	

Calibration Date: 14/12/2010
 Certified By:

Robert Haydock
 President, AML Oceanographic

AML Oceanographic certifies that the asset described above has been calibrated or recalibrated with equipment referenced to traceable standards. Please note that Xchange™ sensor-heads may be installed on assets other than the one listed above; this calibration certificate will still be valid when used on other such assets. If this instrument or sensor has been recalibrated, please be sure to update your records. Please also ensure that you update the instrument's coefficient values in any post-processing software that you use, if necessary. Older generation instruments may require configuration files, which are available for download at our Customer Centre at www.AMLoceanographic.com/support

Date:
Apr 16, 2009

DIGIBAR CALIBRATION REPORT

version 1.0 (c) 2004

Serial #:
98013-041609

ODOM HYDROGRAPHIC SYSTEMS, Inc.



STANDARD DEL GROSSO H²O

TEMP	VELOCITY	MEASURED	RES_VEL	OBS-CAL	TEMP	VELOCITY	MEASURED	RES_VEL	OBS-CAL
FREQUENCY					FREQUENCY				
4.00	1421.62	5555.38	1421.72	0.10	17.50	1474.38	5754.23	1474.39	0.01
4.50	1423.90	5563.65	1423.91	0.01	18.00	1476.01	5760.25	1475.98	-0.03
5.00	1426.15	5572.06	1426.14	-0.01	18.50	1477.62	5766.61	1477.67	0.05
5.50	1428.38	5580.63	1428.41	0.03	19.00	1479.21	5772.53	1479.24	0.03
6.00	1430.58	5588.91	1430.60	0.02	19.50	1480.77	5778.59	1480.84	0.07
6.50	1432.75	5597.16	1432.79	0.04	20.00	1482.32	5784.53	1482.42	0.10
7.00	1434.90	5605.25	1434.93	0.03	20.50	1483.84	5790.02	1483.87	0.03
7.50	1437.02	5612.62	1436.88	-0.14	21.00	1485.35	5795.92	1485.43	0.09
8.00	1439.12	5621.12	1439.13	0.02	21.50	1486.83	5801.44	1486.89	0.07
8.50	1441.19	5629.22	1441.28	0.09	22.00	1488.29	5806.96	1488.36	0.06
9.00	1443.23	5636.66	1443.25	0.02	22.50	1489.74	5812.30	1489.77	0.03
9.50	1445.25	5643.93	1445.18	-0.08	23.00	1491.16	5817.59	1491.17	0.01
10.00	1447.25	5651.96	1447.30	0.05	23.50	1492.56	5822.88	1492.57	0.01
10.50	1449.22	5659.15	1449.21	-0.02	24.00	1493.95	5828.51	1494.06	0.11
11.00	1451.17	5666.35	1451.11	-0.06	24.50	1495.32	5833.69	1495.44	0.12
11.50	1453.09	5673.82	1453.09	0.00	25.00	1496.66	5838.75	1496.78	0.11
12.00	1454.99	5681.13	1455.03	0.03	25.50	1497.99	5843.82	1498.12	0.13
12.50	1456.87	5688.13	1456.88	0.01	26.00	1499.30	5848.69	1499.41	0.11
13.00	1458.72	5695.22	1458.76	0.04	26.50	1500.59	5853.57	1500.70	0.11
13.50	1460.55	5702.13	1460.59	0.04	27.00	1501.86	5858.39	1501.98	0.12
14.00	1462.36	5708.74	1462.34	-0.02	27.50	1503.11	5862.89	1503.17	0.06
14.50	1464.14	5715.63	1464.17	0.02	28.00	1504.35	5867.72	1504.45	0.10
15.00	1465.91	5722.21	1465.91	0.00	28.50	1505.56	5872.44	1505.70	0.14
15.50	1467.65	5728.99	1467.70	0.06	29.00	1506.76	5876.95	1506.89	0.13
16.00	1469.36	5735.28	1469.37	0.01	29.50	1507.94	5881.41	1508.08	0.13
16.50	1471.06	5741.78	1471.09	0.04	30.00	1509.10	5885.67	1509.20	0.10
17.00	1472.73	5748.03	1472.75	0.02					

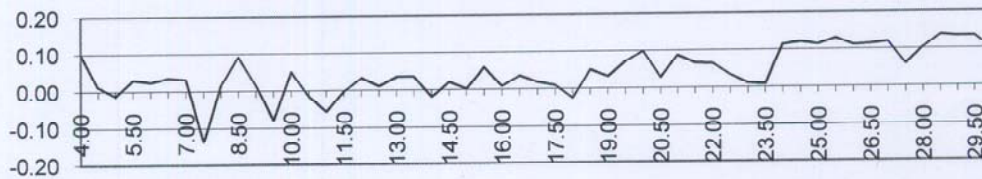

Odom Hydrographic Systems, Inc.

1450 SeaBoard Avenue, Baton Rouge, Louisiana 70810-6261, USA
Telephone: (225)-769-3051, Facsimile: (225)-766-5122
E-mail: email@odomhydrographic.com, HTTP: www.odomhydrographic.com

Date:
Apr 16, 2009

Serial #:
98013-041609

DIGIBAR CALIBRATION REPORT

version 1.0 (c) 2004

ODOM HYDROGRAPHIC SYSTEMS, Inc.



Burn these numbers to EPROM:

Gradient
Intercept

3391
497

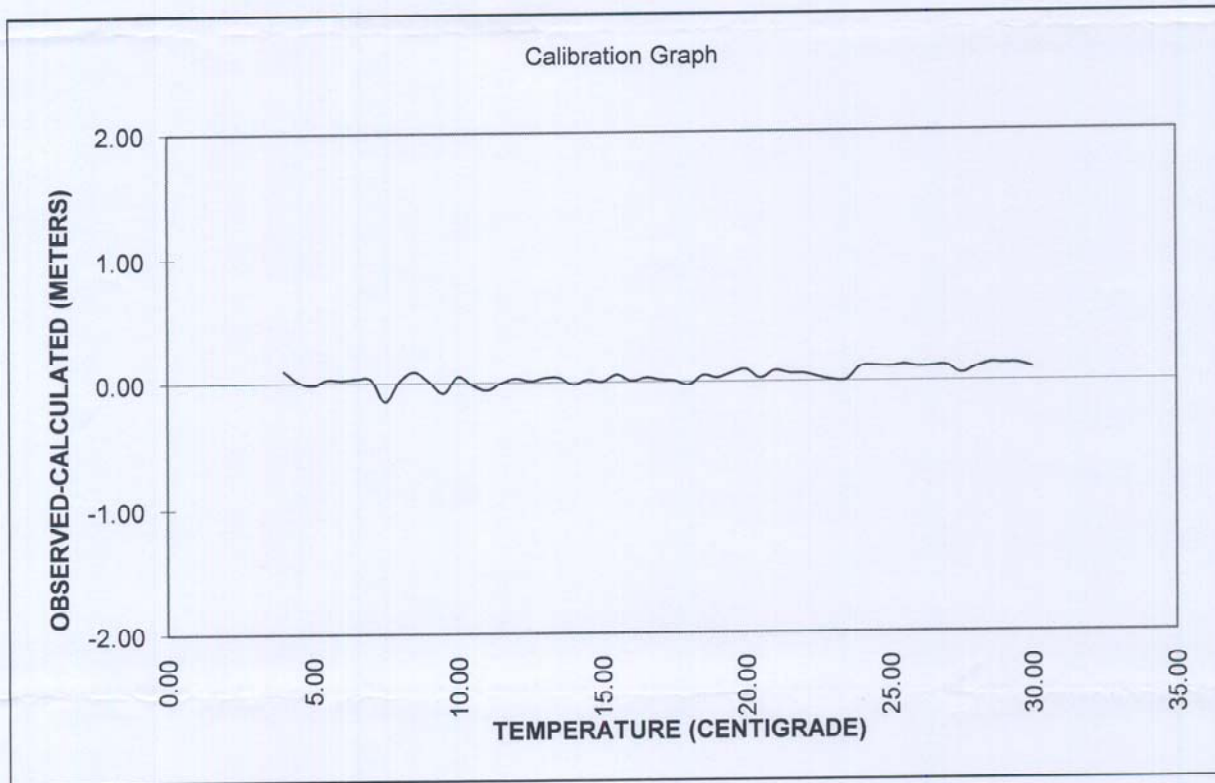

The instruments used in this calibration have been calibrated to the published manufacturer specifications using standards traceable to NIST, to consensus standards, to ratio methods, or to acceptable values of natural physical constants that meets the requirements of ANSI/NCSL Z540-1, ISO 9001, ISO 10012 and ISO 17025. Certificate/traceability numbers: 0002-2655.00-23491-001, 0002-2655.00-23491-002. ID#s:294,295,762,172,56



Odom Hydrographic Systems, Inc.

1450 SeaBoard Avenue, Baton Rouge, Louisiana 70810-6261, USA
Telephone: (225)-769-3051, Facsimile: (225)-766-5122
E-mail: email@odomhydrographic.com, [HTTP: www.odomhydrographic.com](http://www.odomhydrographic.com)



Date	4/17/2009
Serial #	98013
SW Version	1.11
Cable Length	20 meters

Press Transducer	79842
Zero Voltage	.18
Span Voltage	2.68
Mid-Scale Voltage	1.43
R5	3.9K
R9	10K
Gradient	3391
Intercept	497

Max psi:	200 psi
Velocity Check:	√
Depth Check:	√
Communications:	√
External Power:	NA

Board Identification	Serial #
Power Supply	
Control PCB	
LCD	
Probe Sensor	
Probe Controller	
Airmar Transducer	853906

Pressure Transducer Linearity

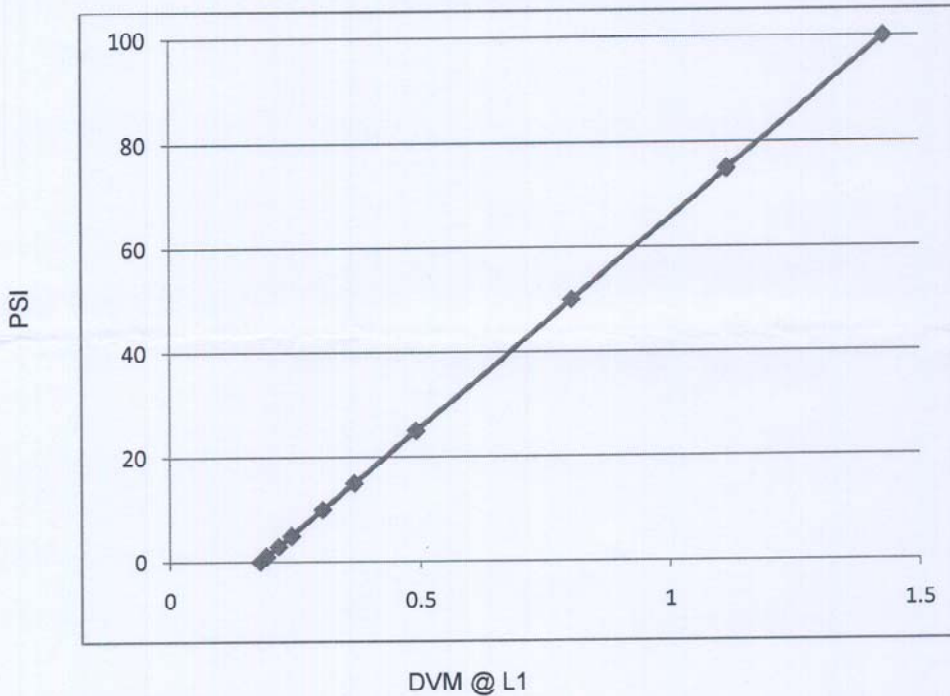

Transducer Linearity	
PSI	DVM@L1
0	0.18
1	0.192
3	0.217
5	0.242
10	0.304
15	0.367
25	0.491
50	0.804
75	1.116
100	1.43

SBE SEA-BIRD ELECTRONICS, INC.

13431 NE 20th St. Bellevue, Washington 98005 USA



Phone: (425) 643-9866 Fax: (425) 643-9954 www.seabird.com

Service

Report

RMA Number

66668

Customer Information:

Company Pacific Marine Center / NOAA Date 11/29/2011

Contact Dave Francksen

PO Number TBD

Serial Number 19P36026-4585

Model Number SBE 19Plus

Services Requested:

1. Evaluate/Repair Instrumentation.
2. Perform Routine Calibration Service.

Problems Found:

1. There was a cut found in pump cable.

Services Performed:

1. Performed initial diagnostic evaluation.
2. Performed "Post Cruise" calibration of the temperature & conductivity sensors.
3. Calibrated the pressure sensor.
4. Installed NEW pump interface cable, 44".
5. Performed complete system check and full diagnostic evaluation.

Special Notes:



SEA-BIRD ELECTRONICS, INC.

13431 NE 20th St. Bellevue, Washington 98005 USA

Phone: (425) 643-9866 Fax: (425) 643-9954 www.seabird.com

Temperature Calibration Report

Customer:	Pacific Marine Center / NOAA		
Job Number:	66668	Date of Report:	11/14/2011
Model Number:	SBE 19Plus	Serial Number:	19P36026-4585

Temperature sensors are normally calibrated 'as received', without adjustments, allowing a determination sensor drift. If the calibration identifies a problem, then a second calibration is performed after work is completed. The 'as received' calibration is not performed if the sensor is damaged or non-functional, or by customer request.

An 'as received' calibration certificate is provided, listing coefficients to convert sensor frequency to temperature. Users must choose whether the 'as received' calibration or the previous calibration better represents the sensor condition during deployment. In SEASOFT enter the chosen coefficients using the program SEACON. The coefficient 'offset' allows a small correction for drift between calibrations (consult the SEASOFT manual). Calibration coefficients obtained after a repair apply only to subsequent data.

'AS RECEIVED CALIBRATION'

Performed Not Performed

Date: 11/13/2011

Drift since last cal: +0.00061 Degrees Celsius/year

Comments:

'CALIBRATION AFTER REPAIR'

Performed Not Performed

Date:

Drift since Last cal: Degrees Celsius/year

Comments:

Sea-Bird Electronics, Inc.

13431 NE 20th Street, Bellevue, WA 98005-2010 USA

Phone: (+1) 425-643-9866 Fax (+1) 425-643-9954 Email: seabird@seabird.com

SENSOR SERIAL NUMBER: 4585
CALIBRATION DATE: 13-Nov-11

SBE19plus TEMPERATURE CALIBRATION DATA
ITS-90 TEMPERATURE SCALE

ITS-90 COEFFICIENTS

a0 = 1.139484e-003
a1 = 2.818564e-004
a2 = -1.832282e-006
a3 = 2.163514e-007

BATH TEMP (ITS-90)	INSTRUMENT OUTPUT(n)	INST TEMP (ITS-90)	RESIDUAL (ITS-90)
1.0000	686668.033	1.0001	0.0001
4.5000	613990.311	4.4999	-0.0001
15.0000	430452.617	15.0002	0.0002
18.5000	380360.233	18.4999	-0.0001
24.0000	311750.148	23.9999	-0.0001
29.0000	259034.279	29.0001	0.0001
32.5000	226977.767	32.5000	-0.0000

$$MV = (n - 524288) / 1.6e+007$$

$$R = (MV * 2.900e+009 + 1.024e+008) / (2.048e+004 - MV * 2.0e+005)$$

$$\text{Temperature ITS-90} = 1 / \{a_0 + a_1[ln(R)] + a_2[ln^2(R)] + a_3[ln^3(R)]\} - 273.15 \text{ (}^\circ\text{C)}$$

Residual = instrument temperature - bath temperature

Date, Delta T (mdeg C)

● 03-Dec-10 -0.58
▲ 13-Nov-11 0.00

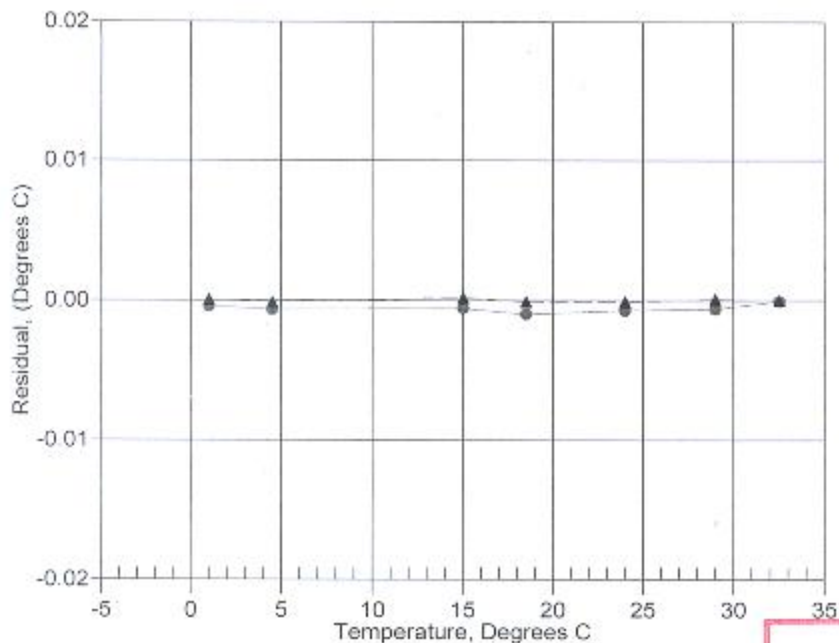

**POST CRUISE
CALIBRATION**



SEA-BIRD ELECTRONICS, INC.

13431 NE 20th Street Bellevue, Washington 98005 USA

Phone: (425) 643-9866 Fax: (425) 643-9954 www.seabird.com

Conductivity Calibration Report

Customer:	Pacific Marine Center / NOAA		
Job Number:	66668	Date of Report:	11/14/2011
Model Number:	SBE 19Plus	Serial Number:	19P36026-4585

Conductivity sensors are normally calibrated 'as received', without cleaning or adjustments, allowing a determination of sensor drift. If the calibration identifies a problem or indicates cell cleaning is necessary, then a second calibration is performed after work is completed. The 'as received' calibration is not performed if the sensor is damaged or non-functional, or by customer request.

An 'as received' calibration certificate is provided, listing the coefficients used to convert sensor frequency to conductivity. Users must choose whether the 'as received' calibration or the previous calibration better represents the sensor condition during deployment. In SEASOFT enter the chosen coefficients using the program SEACON. The coefficient 'slope' allows small corrections for drift between calibrations (consult the SEASOFT manual). Calibration coefficients obtained after a repair or cleaning apply only to subsequent data.

'AS RECEIVED CALIBRATION'

Performed Not Performed

Date: 11/13/2011

Drift since last cal: -0.00010 PSU/month*

Comments:

'CALIBRATION AFTER CLEANING & REPLATINIZING'

Performed Not Performed

Date:

Drift since Last cal: PSU/month*

Comments:

*Measured at 3.0 S/m

Cell cleaning and electrode replatinizing tend to 'reset' the conductivity sensor to its original condition. Lack of drift in post-cleaning-calibration indicates geometric stability of the cell and electrical stability of the sensor circuit.

Sea-Bird Electronics, Inc.

13431 NE 20th Street, Bellevue, WA 98005-2010 USA

Phone: (+1) 425-643-9866 Fax (+1) 425-643-9954 Email: seabird@seabird.com

SENSOR SERIAL NUMBER: 4585
CALIBRATION DATE: 13-Nov-11

SBE19plus CONDUCTIVITY CALIBRATION DATA
PSS 1978: C(35,15.0) = 4.2914 Siemens/meter

COEFFICIENTS:

g = -1.030567e+000
h = 1.491745e-001
i = -2.066452e-004
j = 3.796541e-005

CPcor = -9.5700e-008
CTcor = 3.2500e-006

BATH TEMP (ITS-90)	BATH SAL (PSU)	BATH COND (Siemens/m)	INST FREQ (Hz)	INST COND (Siemens/m)	RESIDUAL (Siemens/m)
22.0000	0.0000	0.00000	2630.88	0.0000	0.00000
1.0000	34.6846	2.96578	5176.80	2.9658	0.00000
4.5000	34.6641	3.27178	5370.68	3.2718	0.00000
15.0000	34.6206	4.25014	5947.59	4.2501	-0.00000
18.5000	34.6111	4.59408	6137.28	4.5941	0.00000
24.0000	34.6008	5.15010	6431.81	5.1501	-0.00000
29.0000	34.5949	5.67012	6695.26	5.6701	0.00001
32.5000	34.5905	6.04105	6876.82	6.0410	-0.00001

f = INST FREQ / 1000.0

Conductivity = $(g + hf^2 + if^3 + jf^4) / (1 + \delta t + \epsilon p)$ Siemens/meter

t = temperature[°C]; p = pressure[decibars]; δ = CTcor; ϵ = CPcor;

Residual = instrument conductivity - bath conductivity *

Date, Slope Correction

● 03-Dec-10 0.9999516
▲ 13-Nov-11 1.0000000

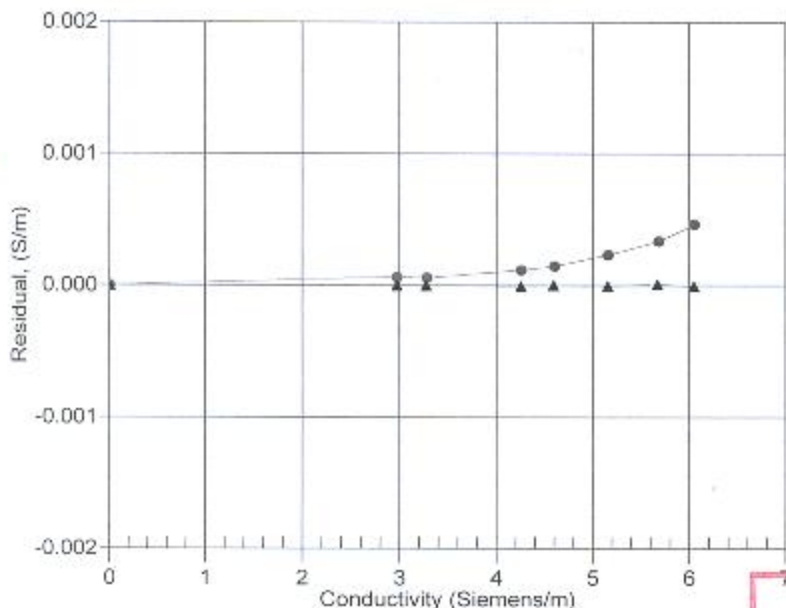

**POST CRUISE
CALIBRATION**

Sea-Bird Electronics, Inc.

13431 NE 20th Street, Bellevue, WA 98005-2010 USA

Phone: (+1) 425-643-9866 Fax (+1) 425-643-9954 Email: seabird@seabird.com

SENSOR SERIAL NUMBER: 4585
CALIBRATION DATE: 10-Nov-11

SBE19plus PRESSURE CALIBRATION DATA
5076 psia S/N 5433

COEFFICIENTS:

PA0 = 4.984914e-001
PA1 = 1.545880e-002
PA2 = -6.591717e-010
PTEMPA0 = -6.658975e+001
PTEMPA1 = 5.227372e+001
PTEMPA2 = -5.209045e-001

PTCA0 = 5.088054e+005
PTCA1 = -9.739418e-001
PTCA2 = 1.041233e-001
PTCB0 = 2.398063e+001
PTCB1 = -2.075000e-003
PTCB2 = 0.000000e+000

PRESSURE SPAN CALIBRATION

PRESSURE PSIA	INST OUTPUT	THERMISTOR OUTPUT	COMPUTED PRESSURE	ERROR %FSR
14.66	509750.0	1.7	14.69	0.00
1114.91	580990.0	1.7	1114.62	-0.01
2114.99	646129.0	1.7	2114.49	-0.01
3115.04	711664.0	1.7	3114.78	-0.01
4115.06	777562.0	1.7	4114.89	-0.00
5069.11	840513.0	1.7	5064.91	-0.00
4115.00	777599.0	1.7	4115.44	0.01
3114.96	711706.0	1.7	3115.41	0.01
2115.00	646178.0	1.7	2115.24	0.00
1114.86	581016.0	1.7	1115.02	0.00
14.66	509755.0	1.7	14.76	0.00

THERMAL CORRECTION

TEMP ITS90	THERMISTOR OUTPUT	INST OUTPUT
32.50	1.93	509781.57
29.00	1.86	509757.55
24.00	1.76	509734.98
18.50	1.66	509718.82
15.00	1.59	509711.50
4.50	1.38	509699.02
1.00	1.31	509698.77

TEMP (ITS90)	SPAN (mV)
-5.00	23.99
35.00	23.91

$$y = \text{thermistor output}; t = PTEMPA0 + PTEMPA1 * y - PTEMPA2 * y^2$$

$$x = \text{pressure output} - PTCA0 - PTCA1 * t - PTCA2 * t^2$$

$$n = x * PTCB0 / (PTCB0 + PTCB1 * t - PTCB2 * t^2)$$

$$\text{pressure (psia)} = PA0 + PA1 * n + PA2 * n^2$$

Date, Avg Delta P %FS

● | 10-Nov-11 -0.00

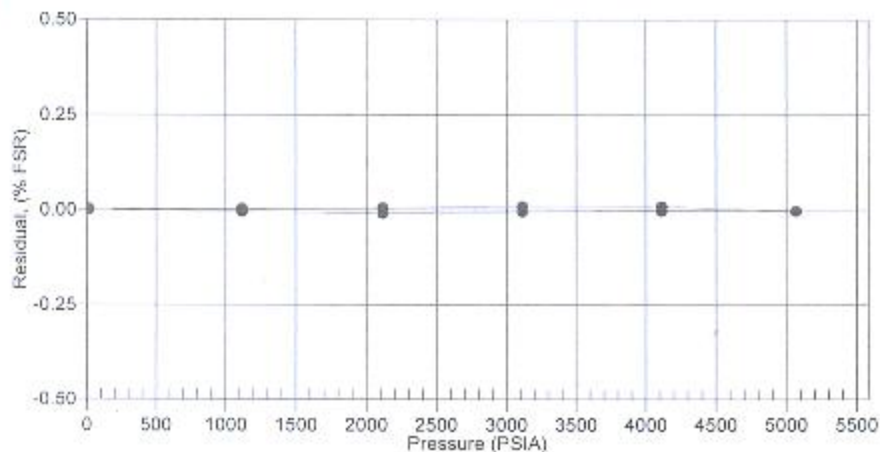

SBE SEA-BIRD ELECTRONICS, INC.

13431 NE 20th St. Bellevue, Washington 98005 USA



Phone: (425) 643-9866 Fax: (425) 643-9954 www.seabird.com

Service

Report

RMA Number

67182

Customer Information:

Company Pacific Marine Center / NOAA

Date 1/12/2012

Contact Gordon Manning

PO Number AB133M12SE0275

Serial Number 19P36026-4616

Model Number SBE 19Plus

Services Requested:

1. Evaluate/Repair Instrumentation.
2. Perform Routine Calibration Service.

Problems Found:

Services Performed:

1. Performed initial diagnostic evaluation.
2. Performed "Post Cruise" calibration of the temperature & conductivity sensors.
3. Calibrated the pressure sensor.
4. Performed complete system check and full diagnostic evaluation.

Special Notes:



SEA-BIRD ELECTRONICS, INC.

13431 NE 20th Street Bellevue, Washington 98005 USA

Phone: (425) 643-9866 Fax: (425) 643-9954 www.seabird.com

Conductivity Calibration Report

Customer:	Pacific Marine Center / NOAA		
Job Number:	67182	Date of Report:	12/30/2011
Model Number:	SBE 19Plus	Serial Number:	19P36026-4616

Conductivity sensors are normally calibrated 'as received', without cleaning or adjustments, allowing a determination of sensor drift. If the calibration identifies a problem or indicates cell cleaning is necessary, then a second calibration is performed after work is completed. The 'as received' calibration is not performed if the sensor is damaged or non-functional, or by customer request.

An 'as received' calibration certificate is provided, listing the coefficients used to convert sensor frequency to conductivity. Users must choose whether the 'as received' calibration or the previous calibration better represents the sensor condition during deployment. In SEASOFT enter the chosen coefficients. The coefficient 'slope' allows small corrections for drift between calibrations (consult the SEASOFT manual). Calibration coefficients obtained after a repair or cleaning apply only to subsequent data.

'AS RECEIVED CALIBRATION'

Performed Not Performed

Date: 12/30/2011

Drift since last cal: +0.00010 PSU/month*

Comments:

'CALIBRATION AFTER CLEANING & REPLATINIZING'

Performed Not Performed

Date:

Drift since Last cal: PSU/month*

Comments:

**Measured at 3.0 S/m*

Cell cleaning and electrode replatinizing tend to 'reset' the conductivity sensor to its original condition. Lack of drift in post-cleaning-calibration indicates geometric stability of the cell and electrical stability of the sensor circuit.

Sea-Bird Electronics, Inc.

13431 NE 20th Street, Bellevue, WA 98005-2010 USA

Phone: (+1) 425-643-9868 Fax (+1) 425-643-9954 Email: seabird@seabird.com

SENSOR SERIAL NUMBER: 4616
CALIBRATION DATE: 30-Dec-11

SBE19plus CONDUCTIVITY CALIBRATION DATA
PSS 1978: C(35,15.0) = 4.2914 Siemens/meter

COEFFICIENTS:

g = -1.045737e+000
h = 1.453805e-001
i = -2.835326e-004
j = 4.091390e-005

CPcor = -9.5700e-008
CTcor = 3.2500e-006

BATH TEMP (ITS-90)	BATH SAL (PSU)	BATH COND (Siemens/m)	INST FREQ (Hz)	INST COND (Siemens/m)	RESIDUAL (Siemens/m)
22.0000	0.0000	0.00000	2686.31	0.0000	0.00000
1.0454	34.8904	2.98564	5272.41	2.9856	0.00000
4.5732	34.8699	3.29586	5470.95	3.2959	-0.00000
15.0000	34.8265	4.27273	6053.04	4.2727	-0.00000
18.5000	34.8170	4.61845	6245.79	4.6184	-0.00000
24.0000	34.8060	5.17726	6545.08	5.1773	0.00001
29.0000	34.7981	5.69967	6812.67	5.6997	-0.00000
32.5000	34.7909	6.07205	6996.98	6.0721	-0.00000

f = INST FREQ / 1000.0

Conductivity = (g + hf² + if³ + jf⁶) / (1 + δt + εp) Siemens/meter

t = temperature[°C]; p = pressure[decibars]; δ = CTcor; ε = CPcor;

Residual = instrument conductivity - bath conductivity *

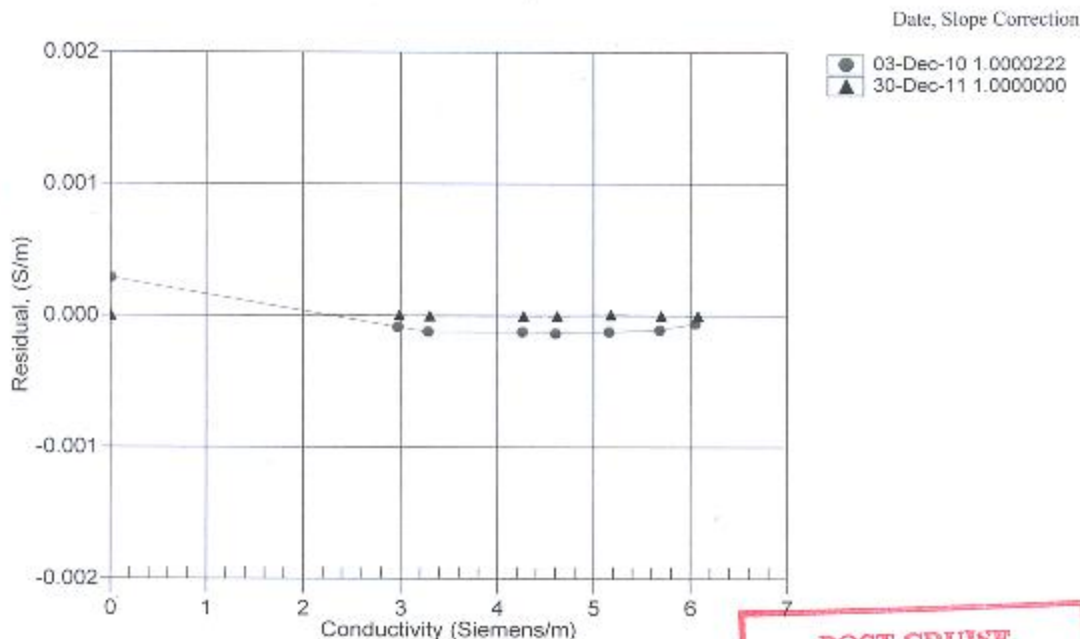

**POST CRUISE
CALIBRATION**



SEA-BIRD ELECTRONICS, INC.

13431 NE 20th St. Bellevue, Washington 98005 USA

Phone: (425) 643-9866 Fax: (425) 643-9954 www.seabird.com

Temperature Calibration Report

Customer:	Pacific Marine Center / NOAA		
Job Number:	87182	Date of Report:	12/30/2011
Model Number:	SBE 19Plus	Serial Number:	19P36026-4616

Temperature sensors are normally calibrated 'as received', without adjustments, allowing a determination sensor drift. If the calibration identifies a problem, then a second calibration is performed after work is completed. The 'as received' calibration is not performed if the sensor is damaged or non-functional, or by customer request.

An 'as received' calibration certificate is provided, listing coefficients to convert sensor frequency to temperature. Users must choose whether the 'as received' calibration or the previous calibration better represents the sensor condition during deployment. In SEASOFT enter the chosen coefficients. The coefficient 'offset' allows a small correction for drift between calibrations (consult the SEASOFT manual). Calibration coefficients obtained after a repair apply only to subsequent data.

'AS RECEIVED CALIBRATION'

Performed Not Performed

Date: 12/30/2011

Drift since last cal: +0.00008 Degrees Celsius/year

Comments:

'CALIBRATION AFTER REPAIR'

Performed Not Performed

Date:

Drift since Last cal: Degrees Celsius/year

Comments:

Sea-Bird Electronics, Inc.

13431 NE 20th Street, Bellevue, WA 98005-2010 USA

Phone: (+1) 425-643-9866 Fax (+1) 425-643-9954 Email: seabird@seabird.com

SENSOR SERIAL NUMBER: 4616
CALIBRATION DATE: 30-Dec-11

SBE19plus TEMPERATURE CALIBRATION DATA
ITS-90 TEMPERATURE SCALE

ITS-90 COEFFICIENTS

a0 = 1.275095e-003
a1 = 2.558142e-004
a2 = 7.531416e-007
a3 = 1.190886e-007

BATH TEMP (ITS-90)	INSTRUMENT OUTPUT(n)	INST TEMP (ITS-90)	RESIDUAL (ITS-90)
1.0454	621400.932	1.0454	-0.0000
4.5732	551166.644	4.5732	0.0000
15.0000	379387.102	14.9999	-0.0001
18.5000	332896.831	18.5001	0.0001
24.0000	269797.729	24.0000	-0.0000
29.0000	221778.712	29.0000	0.0000
32.5000	192781.627	32.5000	-0.0000

$MV = (n - 524288) / 1.6e+007$

$R = (MV * 2.900e+009 + 1.024e+008) / (2.048e+004 - MV * 2.0e+005)$

Temperature ITS-90 = $1 / \{a0 + a1[\ln(R)] + a2[\ln^2(R)] + a3[\ln^3(R)]\} - 273.15$ (°C)

Residual = instrument temperature - bath temperature

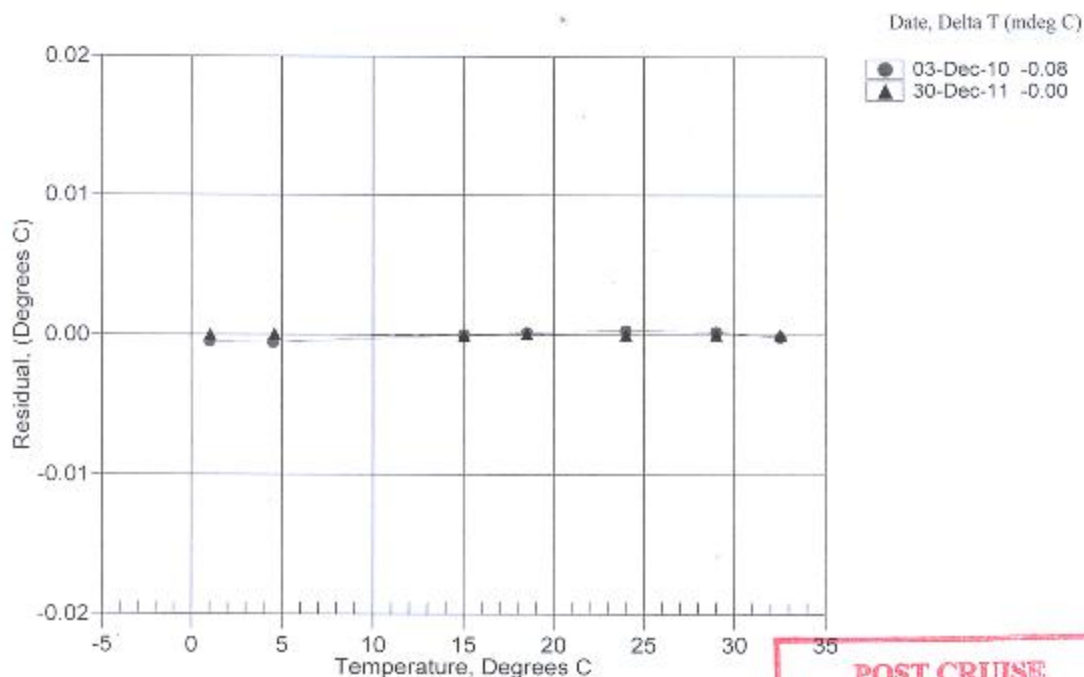

Sea-Bird Electronics, Inc.

13431 NE 20th Street, Bellevue, WA 98005-2010 USA

Phone: (+1) 425-643-9866 Fax (+1) 425-643-9954 Email: seabird@seabird.com

SENSOR SERIAL NUMBER: 4616
CALIBRATION DATE: 29-Dec-11

SBE19plus PRESSURE CALIBRATION DATA
1450 psia S/N 5512

COEFFICIENTS:

PA0 = 7.457638e-001
PA1 = 4.427613e-003
PA2 = -1.118924e-011
PTEMPA0 = -7.653011e+001
PTEMPA1 = 4.931565e+001
PTEMPA2 = -2.752292e-001

PTCA0 = 5.204284e+005
PTCA1 = 1.284862e+001
PTCA2 = -2.343791e-001
PTCB0 = 2.473825e+001
PTCB1 = 5.000000e-005
PTCB2 = 0.000000e+000

PRESSURE SPAN CALIBRATION

PRESSURE PSIA	INST OUTPUT	THERMISTOR OUTPUT	COMPUTED PRESSURE	ERROR %FSR
14.65	523742.0	2.0	14.67	0.00
314.93	591566.0	2.0	314.90	-0.00
614.93	659362.0	2.0	614.90	-0.00
914.94	727184.0	2.0	914.91	-0.00
1214.96	795032.0	2.0	1214.94	-0.00
1465.01	851595.0	2.0	1464.98	-0.00
1214.97	795052.0	2.0	1215.02	0.00
914.91	727197.0	2.0	914.97	0.00
614.93	659376.0	2.0	614.96	0.00
314.93	591571.0	2.0	314.92	-0.00
14.65	523740.0	2.0	14.66	0.00

THERMAL CORRECTION

TEMP ITS90	THERMISTOR OUTPUT	INST OUTPUT
32.50	2.24	523795.08
29.00	2.17	523796.58
24.00	2.06	523792.91
18.50	1.95	523776.17
15.00	1.88	523763.29
4.57	1.66	523687.95
1.05	1.59	523626.44

TEMP (ITS90)	SPAN (mV)
-5.00	24.74
35.00	24.74

$$y = \text{thermistor output}; t = PTEMPA0 - PTEMPA1 * y + PTEMPA2 * y^2$$

$$x = \text{pressure output} - PTCA0 - PTCA1 * t - PTCA2 * t^2$$

$$n = x * PTCB0 / (PTCB0 - PTCB1 * t + PTCB2 * t^2)$$

$$\text{pressure (psia)} = PA0 + PA1 * n + PA2 * n^2$$

Date, Avg Delta P %FS

● 29-Dec-11 0.00

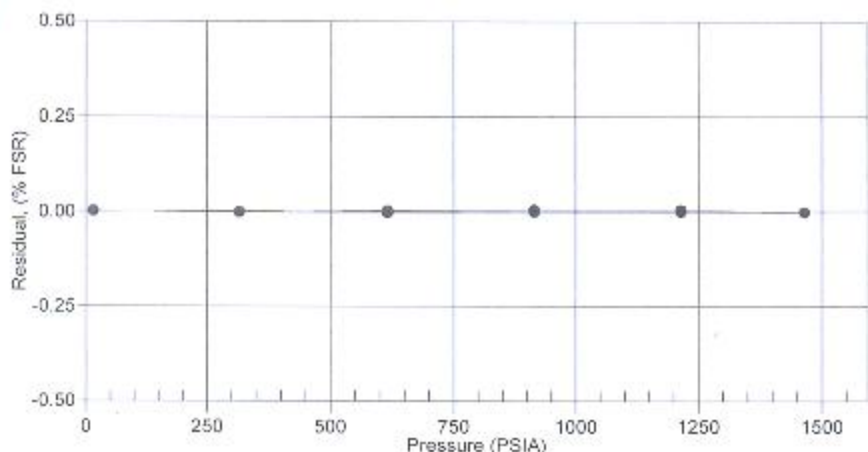

SBE SEA-BIRD ELECTRONICS, INC.

13431 NE 20th St. Bellevue, Washington 98005 USA



Phone: (425) 643-9866 Fax: (425) 643-9954 www.seabird.com

Service

Report

RMA Number

67182

Customer Information:

Company Pacific Marine Center / NOAA Date 1/12/2012

Contact Gordon Manning

PO Number AB133M12SE0275

Serial Number 19P36026-4617

Model Number SBE 19Plus

Services Requested:

1. Evaluate/Repair Instrumentation.
2. Perform Routine Calibration Service.

Problems Found:

Services Performed:

1. Performed initial diagnostic evaluation.
2. Performed "Post Cruise" calibration of the temperature & conductivity sensors.
3. Calibrated the pressure sensor.
4. Performed complete system check and full diagnostic evaluation.

Special Notes:



SEA-BIRD ELECTRONICS, INC.

13431 NE 20th Street Bellevue, Washington 98005 USA

Phone: (425) 643-9866 Fax: (425) 643-9954 www.seabird.com

Conductivity Calibration Report

Customer:	Pacific Marine Center / NOAA		
Job Number:	67182	Date of Report:	12/30/2011
Model Number:	SBE 19Plus	Serial Number:	19P36026-4617

Conductivity sensors are normally calibrated 'as received', without cleaning or adjustments, allowing a determination of sensor drift. If the calibration identifies a problem or indicates cell cleaning is necessary, then a second calibration is performed after work is completed. The 'as received' calibration is not performed if the sensor is damaged or non-functional, or by customer request.

An 'as received' calibration certificate is provided, listing the coefficients used to convert sensor frequency to conductivity. Users must choose whether the 'as received' calibration or the previous calibration better represents the sensor condition during deployment. In SEASOFT enter the chosen coefficients. The coefficient 'slope' allows small corrections for drift between calibrations (consult the SEASOFT manual). Calibration coefficients obtained after a repair or cleaning apply only to subsequent data.

'AS RECEIVED CALIBRATION'

Performed Not Performed

Date: 12/30/2011

Drift since last cal: -0.00010 PSU/month*

Comments:

'CALIBRATION AFTER CLEANING & REPLATINIZING'

Performed Not Performed

Date:

Drift since Last cal: PSU/month*

Comments:

*Measured at 3.0 S/m

Cell cleaning and electrode replatinizing tend to 'reset' the conductivity sensor to its original condition. Lack of drift in post-cleaning-calibration indicates geometric stability of the cell and electrical stability of the sensor circuit.

Sea-Bird Electronics, Inc.

13431 NE 20th Street, Bellevue, WA 98005-2010 USA

Phone: (+1) 425-643-9866 Fax (+1) 425-643-9954 Email: seabird@seabird.com

SENSOR SERIAL NUMBER: 4617
CALIBRATION DATE: 30-Dec-11

SBE19plus CONDUCTIVITY CALIBRATION DATA
PSS 1978: C(35,15,0) - 4.2914 Siemens/meter

COEFFICIENTS:

g = -9.988685e-001
h = 1.277388e-001
i = -2.525321e-004
j = 3.372716e-005

CPcor = -9.5700e-008
CTcor = 3.2500e-006

BATH TEMP (ITS-90)	BATH SAL (PSU)	BATH COND (Siemens/m)	INST FREQ (Hz)	INST COND (Siemens/m)	RESIDUAL (Siemens/m)
22.0000	0.0000	0.00000	2801.22	0.0000	0.00000
1.0454	34.8904	2.98564	5592.86	2.9856	-0.00001
4.5732	34.8699	3.29586	5805.91	3.2959	0.00001
15.0000	34.8265	4.27273	6429.97	4.2727	0.00001
18.5000	34.8170	4.61845	6636.48	4.6184	-0.00001
24.0000	34.8060	5.17726	6957.01	5.1773	-0.00000
29.0000	34.7981	5.69967	7243.48	5.6997	-0.00001
32.5000	34.7909	6.07206	7440.75	6.0721	0.00001

f = INST FREQ / 1000.0

Conductivity = (g + hf² + if³ + jf⁴) / (1 + δt + εp) Siemens/meter

t = temperature[°C]; p = pressure[decibars]; δ = CTcor; ε = CPcor;

Residual = instrument conductivity - bath conductivity

Date, Slope Correction

● 26-Jan-11 0.9999646
▲ 30-Dec-11 1.0000000

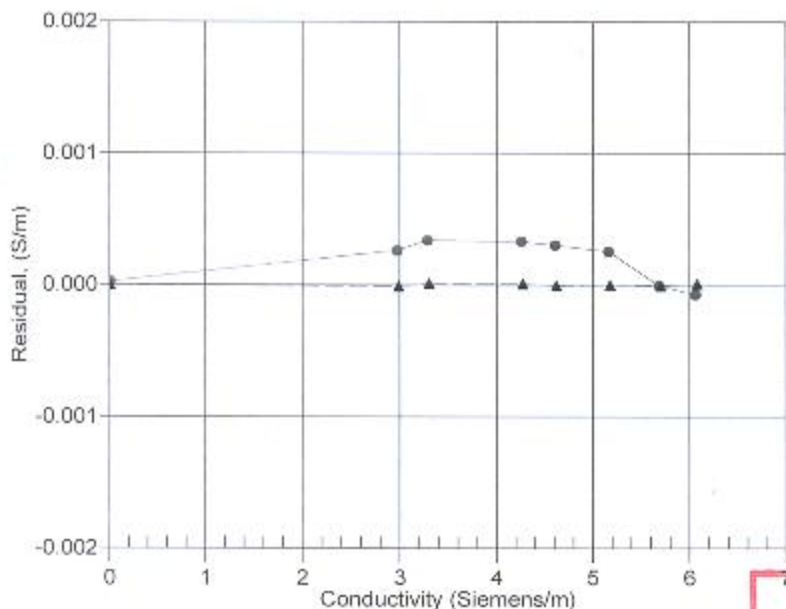

**POST CRUISE
CALIBRATION**



SEA-BIRD ELECTRONICS, INC.

13431 NE 20th St. Bellevue, Washington 98005 USA

Phone: (425) 643-9866 Fax: (425) 643-9954 www.seabird.com

Temperature Calibration Report

Customer:	Pacific Marine Center / NOAA		
Job Number:	67182	Date of Report:	12/30/2011
Model Number:	SBE 19Plus	Serial Number:	19P36026-4817

Temperature sensors are normally calibrated 'as received', without adjustments, allowing a determination sensor drift. If the calibration identifies a problem, then a second calibration is performed after work is completed. The 'as received' calibration is not performed if the sensor is damaged or non-functional, or by customer request.

An 'as received' calibration certificate is provided, listing coefficients to convert sensor frequency to temperature. Users must choose whether the 'as received' calibration or the previous calibration better represents the sensor condition during deployment. In SEASOFT enter the chosen coefficients. The coefficient 'offset' allows a small correction for drift between calibrations (consult the SEASOFT manual). Calibration coefficients obtained after a repair apply only to subsequent data.

'AS RECEIVED CALIBRATION'

Performed Not Performed

Date: 12/30/2011

Drift since last cal: +0.00002 Degrees Celsius/year

Comments:

'CALIBRATION AFTER REPAIR'

Performed Not Performed

Date:

Drift since Last cal: Degrees Celsius/year

Comments:

Sea-Bird Electronics, Inc.

13431 NE 20th Street, Bellevue, WA 98005-2010 USA

Phone: (+1) 425-643-9866 Fax (+1) 425-643-9954 Email: seabird@seabird.com

SENSOR SERIAL NUMBER: 4617
CALIBRATION DATE: 30-Dec-11

SBE19plus TEMPERATURE CALIBRATION DATA
ITS-90 TEMPERATURE SCALE

ITS-90 COEFFICIENTS

a0 = 1.268062e-003
a1 = 2.618261e-004
a2 = 2.676110e-007
a3 = 1.425171e-007

BATH TEMP (ITS-90)	INSTRUMENT OUTPUT(n)	INST TEMP (ITS-90)	RESIDUAL (ITS-90)
1.0454	584729.373	1.0453	-0.0001
4.5732	517465.068	4.5734	0.0002
15.0000	354156.288	14.9999	-0.0001
18.5000	310225.237	18.5000	-0.0000
24.0000	250759.305	24.0001	0.0001
29.0000	205619.220	29.0001	0.0001
32.5000	178404.661	32.4999	-0.0001

$MV = (n - 524288) / 1.6e+007$

$R = (MV * 2.900e+009 + 1.024e+008) / (2.048e+004 - MV * 2.0e+005)$

Temperature ITS-90 = $1 / \{a_0 + a_1[ln(R)] + a_2[ln^2(R)] + a_3[ln^3(R)]\} - 273.15$ (°C)

Residual = instrument temperature - bath temperature

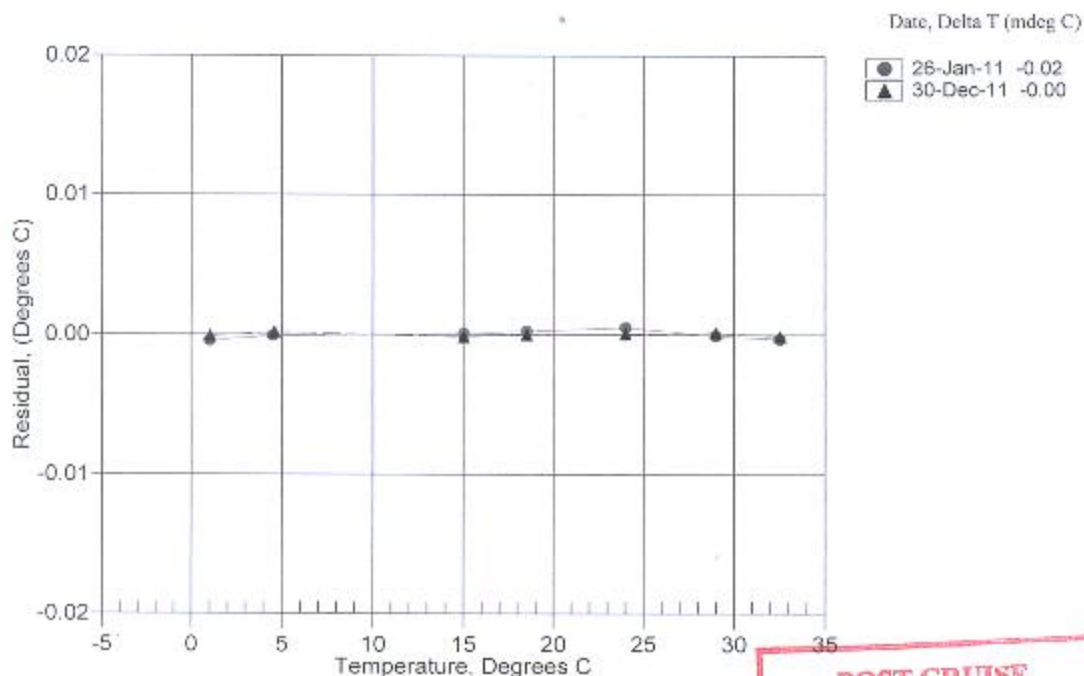

**POST CRUISE
CALIBRATION**

Sea-Bird Electronics, Inc.

13431 NE 20th Street, Bellevue, WA 98005-2010 USA

Phone: (+1) 425-643-9866 Fax (+1) 425-643-9954 Email: seabird@seabird.com

SENSOR SERIAL NUMBER: 4617
CALIBRATION DATE: 29-Dec-11

SBE19plus PRESSURE CALIBRATION DATA
1450 psia S/N 5513

COEFFICIENTS:

PA0 = -4.378044e-001
PA1 = 4.446126e-003
PA2 = -1.172603e-011
PTempa0 = -7.914469e+001
PTempa1 = 4.922856e+001
PTempa2 = -4.1111452e-001

PTCA0 = 5.192622e+005
PTCA1 = -9.699399e+000
PTCA2 = 2.421830e-001
PTCB0 = 2.460838e+001
PTCB1 = 6.750000e-004
PTCB2 = 0.000000e+000

PRESSURE SPAN CALIBRATION

PRESSURE PSIA	INST OUTPUT	THERMISTOR OUTPUT	COMPUTED PRESSURE	ERROR %FSR
14.65	522566.0	2.1	14.67	0.00
314.93	590129.0	2.1	314.82	-0.01
614.95	657693.0	2.1	614.88	-0.01
914.94	725280.0	2.1	914.92	-0.00
1214.96	792885.0	2.1	1214.94	-0.00
1465.01	849245.0	2.1	1464.97	-0.00
1214.97	792904.0	2.1	1215.02	0.00
914.91	725293.0	2.1	914.98	0.00
614.93	657718.0	2.1	614.98	0.00
314.93	590157.0	2.1	314.95	0.00
14.65	522567.0	2.1	14.67	0.00

THERMAL CORRECTION

TEMP ITS90	THERMISTOR OUTPUT	INST OUTPUT
32.50	2.31	522635.00
29.00	2.24	522629.32
24.00	2.13	522618.60
18.50	2.02	522607.59
15.00	1.94	522603.56
4.57	1.73	522653.44
1.05	1.65	522701.08

TEMP (ITS90)	SPAN (mV)
-5.00	24.61
35.00	24.63

$$y = \text{thermistor output}; t = \text{PTempa0} + \text{PTempa1} * y - \text{PTempa2} * y^2$$

$$x = \text{pressure output} - \text{PTCA0} - \text{PTCA1} * t - \text{PTCA2} * t^2$$

$$n = x * \text{PTCB0} / (\text{PTCB0} + \text{PTCB1} * t + \text{PTCB2} * t^2)$$

$$\text{pressure (psia)} = \text{PA0} + \text{PA1} * n - \text{PA2} * n^2$$

Date, Avg Delta P %FS

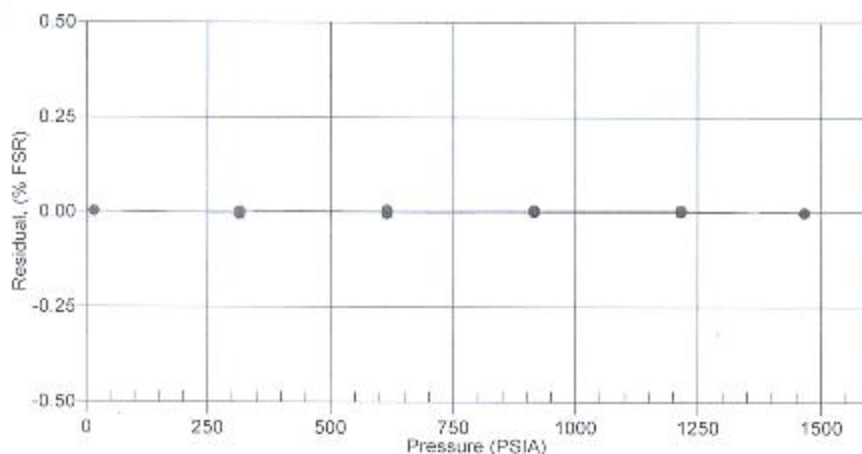

SBE SEA-BIRD ELECTRONICS, INC.

13431 NE 20th St. Bellevue, Washington 98005 USA



Phone: (425) 643-9866 Fax: (425) 643-9954 www.seabird.com

Service

Report

RMA Number

66668

Customer Information:

Company Pacific Marine Center / NOAA

Date 11/29/2011

Contact Dave Francksen

PO Number TBD

Serial Number 19P50959-6121

Model Number SBE 19Plus

Services Requested:

1. Evaluate/Repair Instrumentation.
2. Perform Routine Calibration Service.

Problems Found:

1. 19plus did not communicate upon arrival.
2. This board set has been returned numerous times with communication issues.

Services Performed:

1. Performed initial diagnostic evaluation.
2. Installed NEW SBE 16/19Plus Version II electronic board set assembly with Strain gauge. *
3. Performed internal inspection and O-ring replacement.
4. Performed hydrostatic pressure test.
5. Performed "Final" calibration of the temperature & conductivity sensors.
6. Calibrated the pressure sensor.
7. Performed complete system check and full diagnostic evaluation.

Special Notes:

* Replaced at no charge.



SEA-BIRD ELECTRONICS, INC.

13431 NE 20th St. Bellevue, Washington 98005 USA

Phone: (425) 643-9866 Fax: (425) 643-9954 www.seabird.com

Temperature Calibration Report

Customer:	Pacific Marine Center / NOAA		
Job Number:	66668	Date of Report:	11/19/2011
Model Number:	SBE 19Plus	Serial Number:	19P50959-6121

Temperature sensors are normally calibrated 'as received', without adjustments, allowing a determination sensor drift. If the calibration identifies a problem, then a second calibration is performed after work is completed. The 'as received' calibration is not performed if the sensor is damaged or non-functional, or by customer request.

An 'as received' calibration certificate is provided, listing coefficients to convert sensor frequency to temperature. Users must choose whether the 'as received' calibration or the previous calibration better represents the sensor condition during deployment. In SEASOFT enter the chosen coefficients. The coefficient 'offset' allows a small correction for drift between calibrations (consult the SEASOFT manual). Calibration coefficients obtained after a repair apply only to subsequent data.

'AS RECEIVED CALIBRATION'

Performed Not Performed

Date:

Drift since last cal: Degrees Celsius/year

Comments:

'CALIBRATION AFTER REPAIR'

Performed Not Performed

Date:

Drift since Last cal: Degrees Celsius/year

Comments:

The electronic board set was replaced.

Sea-Bird Electronics, Inc.

13431 NE 20th Street, Bellevue, WA 98005-2010 USA

Phone: (+1) 425-643-9866 Fax (+1) 425-643-9954 Email: seabird@seabird.com

SENSOR SERIAL NUMBER: 6121
CALIBRATION DATE: 19-Nov-11

SBE19plus TEMPERATURE CALIBRATION DATA
ITS-90 TEMPERATURE SCALE

ITS-90 COEFFICIENTS

a0 = 1.280526e-003
a1 = 2.597599e-004
a2 = -2.308032e-007
a3 = 1.476849e-007

BATH TEMP (ITS-90)	INSTRUMENT OUTPUT(n)	INST TEMP (ITS-90)	RESIDUAL (ITS-90)
1.0000	648454.967	1.0001	0.0001
4.5000	575531.467	4.4999	-0.0001
15.0000	394104.607	15.0001	0.0001
18.5000	345371.650	18.5000	0.0000
24.0000	279271.049	23.9998	-0.0002
29.0000	229039.426	29.0001	0.0001
32.5000	198757.656	32.5000	0.0000

$MV = (n - 524288) / 1.6e+007$

$R = (MV * 2.900e+009 + 1.024e+008) / (2.048e+004 - MV * 2.0e+005)$

Temperature [ITS-90] = $1 / \{a_0 + a_1 [ln(R)] + a_2 [ln^2(R)] + a_3 [ln^3(R)]\} - 273.15$ (°C)

Residual = instrument temperature - bath temperature

Date, Delta T (mdeg C)

● 19-Nov-11 0.00

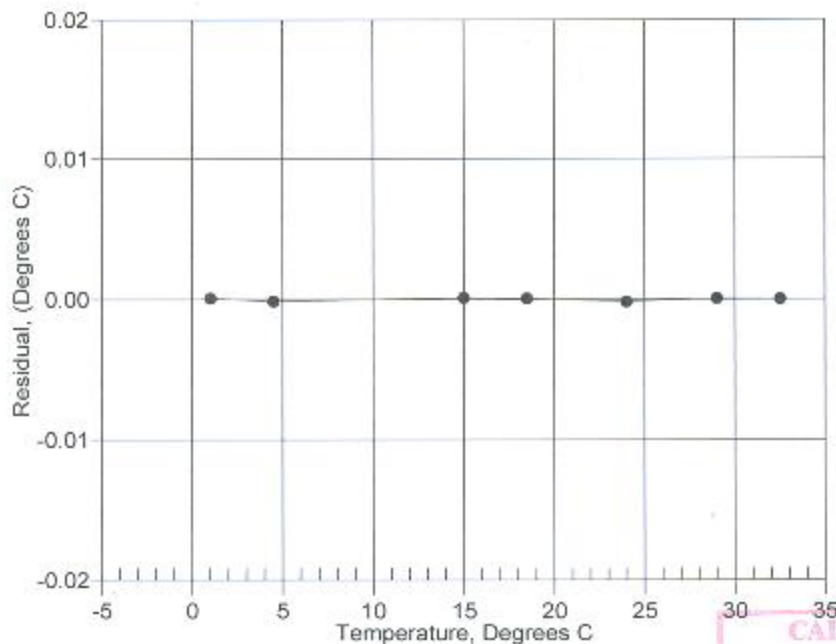

CALIBRATION
AFTER
MODIFICATIONS



SEA-BIRD ELECTRONICS, INC.

13431 NE 20th Street Bellevue, Washington 98005 USA

Phone: (425) 643-9866 Fax: (425) 643-9954 www.seabird.com

Conductivity Calibration Report

Customer:	Pacific Marine Center / NOAA		
Job Number:	66668	Date of Report:	11/19/2011
Model Number:	SBE 19Plus	Serial Number:	19P50959-6121

Conductivity sensors are normally calibrated 'as received', without cleaning or adjustments, allowing a determination of sensor drift. If the calibration identifies a problem or indicates cell cleaning is necessary, then a second calibration is performed after work is completed. The 'as received' calibration is not performed if the sensor is damaged or non-functional, or by customer request.

An 'as received' calibration certificate is provided, listing the coefficients used to convert sensor frequency to conductivity. Users must choose whether the 'as received' calibration or the previous calibration better represents the sensor condition during deployment. In SEASOFT enter the chosen coefficients. The coefficient 'slope' allows small corrections for drift between calibrations (consult the SEASOFT manual). Calibration coefficients obtained after a repair or cleaning apply only to subsequent data.

'AS RECEIVED CALIBRATION'

Performed Not Performed

Date:

Drift since last cal: PSU/month*

Comments:

'CALIBRATION AFTER REPAIR'

Performed Not Performed

Date:

Drift since Last cal: PSU/month*

Comments:

The electronic board set was replaced.

*Measured at 3.0 S/m

Cell cleaning and electrode replatinizing tend to 'reset' the conductivity sensor to its original condition. Lack of drift in post-cleaning-calibration indicates geometric stability of the cell and electrical stability of the sensor circuit.

Sea-Bird Electronics, Inc.

13431 NE 20th Street, Bellevue, WA 98005-2010 USA

Phone: (+1) 425-643-9866 Fax (+1) 425-643-9954 Email: seabird@seabird.com

SENSOR SERIAL NUMBER: 6121
CALIBRATION DATE: 19-Nov-11

SBE19plus CONDUCTIVITY CALIBRATION DATA
PSS 1978: C(35,15,0) - 4.2914 Siemens/meter

COEFFICIENTS:

g = -1.001342e+000
h = 1.548952e-001
i = -3.944174e-004
j = 5.199652e-005

CPcor = -9.5700e-008
CTcor = 3.2500e-006

BATH TEMP (ITS-90)	BATH SAL (PSU)	BATH COND (Siemens/m)	INST FREQ (Hz)	INST COND (Siemens/m)	RESIDUAL (Siemens/m)
22.0000	0.0000	0.00000	2548.06	0.0000	0.00000
1.0000	34.9334	2.98502	5083.92	2.9850	-0.00001
4.5000	34.9127	3.29292	5276.16	3.2929	0.00000
15.0000	34.8689	4.27738	5847.85	4.2774	0.00001
18.5000	34.8594	4.62347	6035.72	4.6235	0.00000
24.0000	34.8489	5.18294	6327.33	5.1829	-0.00001
29.0000	34.8424	5.70611	6588.04	5.7061	-0.00001
32.5000	34.8382	6.07938	6767.74	6.0794	0.00001

f = INST FREQ / 1000.0

Conductivity = $(g + hf^2 + if^3 + jf^4) / (1 + \delta t + \epsilon p)$ Siemens/meter

t = temperature[°C]; p = pressure[decibars]; δ = CTcor; ϵ = CPcor;

Residual = instrument conductivity - bath conductivity *

Date, Slope Correction

● 19-Nov-11 1.000000

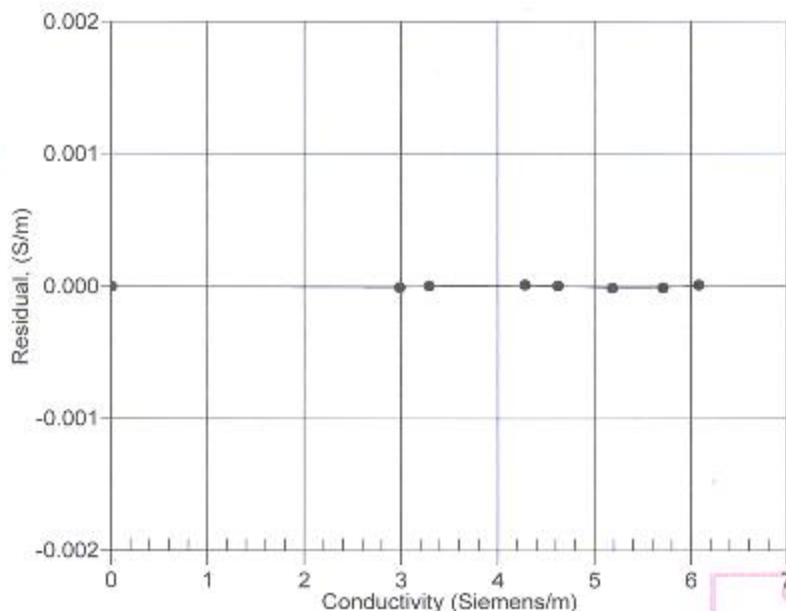

CALIBRATION
AFTER
MODIFICATIONS



SEA-BIRD ELECTRONICS, INC.

13431 NE 20th St. Bellevue, Washington 98005 USA

Phone: (425) 643-9866 Fax: (425) 643-9954 www.seabird.com

Pressure Test Certificate

Customer Pacific Marine Center / NOAA
Job Number 66668
Date 11/16/2011
Technician JK

Serial Number 19P50959-6121

Low Pressure (PSI) 50 PSI

Time (Minutes) 15 Minutes

High Pressure (PSI) 500 PSI

Time (Minutes) 30 Minutes

Pass

Fail

Comments

Replaced the main piston "O"-Rings.

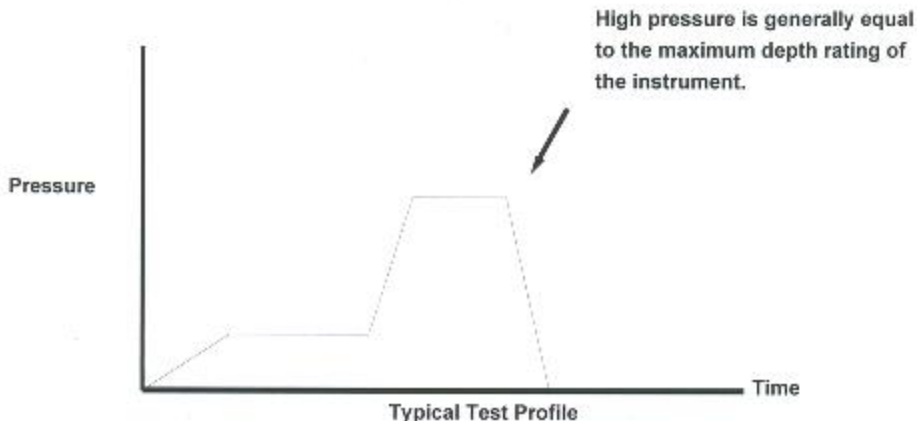

Sea-Bird Electronics, Inc.

13431 NE 20th Street, Bellevue, WA 98005-2010 USA

Phone: (+1) 425-643-9866 Fax (+1) 425-643-9954 Email: seabird@seabird.com

SENSOR SERIAL NUMBER: 6121
CALIBRATION DATE: 17-Nov-11

SBE19plus PRESSURE CALIBRATION DATA
870 psia S/N 2752079

COEFFICIENTS:

PA0 = -1.760545e-001
PA1 = 2.639756e-003
PA2 = 1.805526e-011
PTEMPA0 = -6.063250e+001
PTEMPA1 = 5.462373e+001
PTEMPA2 = -8.079347e-001

PTCA0 = 5.247560e+005
PTCA1 = -3.656991e+000
PTCA2 = 1.610265e-002
PTCB0 = 2.511463e+001
PTCB1 = -1.075000e-003
PTCB2 = 0.000000e+000

PRESSURE SPAN CALIBRATION

PRESSURE PSIA	INST OUTPUT	THERMISTOR OUTPUT	COMPUTED PRESSURE	ERROR %FSR
14.53	530253.0	1.5	14.53	0.00
179.79	592743.0	1.5	179.73	-0.01
359.82	660766.0	1.5	359.71	-0.01
539.79	728740.0	1.5	539.73	-0.01
719.76	796842.0	1.5	719.72	-0.00
874.72	855057.0	1.5	874.70	-0.00
719.77	796685.0	1.5	719.84	0.01
539.78	728792.0	1.5	539.87	0.01
359.79	660820.0	1.5	359.85	0.01
179.78	592786.0	1.5	179.84	0.01
14.53	530251.0	1.5	14.53	0.00

THERMAL CORRECTION

TEMP ITS90	THERMISTOR OUTPUT	INST OUTPUT
32.50	1.75	530334.70
29.00	1.68	530346.39
24.00	1.59	530362.08
18.50	1.48	530376.23
15.00	1.41	530385.11
4.50	1.21	530420.30
1.00	1.15	530436.17

TEMP (ITS90)	SPAN (mV)
-5.00	25.12
35.00	25.08

$$y = \text{thermistor output}; t = PTEMPA0 + PTEMPA1 * y + PTEMPA2 * y^2$$

$$x = \text{pressure output} - PTCA0 - PTCA1 * t - PTCA2 * t^2$$

$$n = x + PTCB0 / (PTCB0 - PTCB1 * t + PTCB2 * t^2)$$

$$\text{pressure (psia)} = PA0 + PA1 * n + PA2 * n^2$$

Date, Avg Delta P %FS

● | 17-Nov-11 -0.00

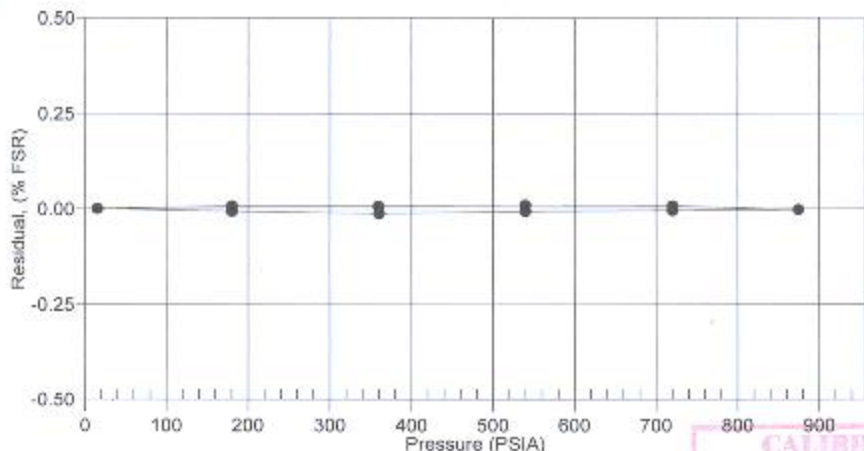

**CALIBRATION
AFTER
MODIFICATIONS**



SEA-BIRD ELECTRONICS, INC.

13431 NE 20th Street Bellevue, Washington 98005 USA

Phone: (425) 643-9866 Fax: (425) 643-9954 www.seabird.com

Conductivity Calibration Report

Customer:	Pacific Marine Center / NOAA		
Job Number:	67182	Date of Report:	1/9/2012
Model Number	SBE 19Plus	Serial Number:	19P50959-6122

Conductivity sensors are normally calibrated 'as received', without cleaning or adjustments, allowing a determination of sensor drift. If the calibration identifies a problem or indicates cell cleaning is necessary, then a second calibration is performed after work is completed. The 'as received' calibration is not performed if the sensor is damaged or non-functional, or by customer request.

An 'as received' calibration certificate is provided, listing the coefficients used to convert sensor frequency to conductivity. Users must choose whether the 'as received' calibration or the previous calibration better represents the sensor condition during deployment. In SEASOFT enter the chosen coefficients. The coefficient 'slope' allows small corrections for drift between calibrations (consult the SEASOFT manual). Calibration coefficients obtained after a repair or cleaning apply only to subsequent data.

'AS RECEIVED CALIBRATION' Performed Not Performed

Date: Drift since last cal: PSU/month*

Comments:

'CALIBRATION AFTER CLEANING & REPLATINIZING' Performed Not Performed

Date: Drift since Last cal: PSU/month*

Comments:

**Measured at 3.0 S/m*

Cell cleaning and electrode replatinizing tend to 'reset' the conductivity sensor to its original condition. Lack of drift in post-cleaning-calibration indicates geometric stability of the cell and electrical stability of the sensor circuit.

Sea-Bird Electronics, Inc.

13431 NE 20th Street, Bellevue, WA 98005-2010 USA

Phone: (+1) 425-643-9866 Fax (+1) 425-643-9954 Email: seabird@seabird.com

SENSOR SERIAL NUMBER: 6122
CALIBRATION DATE: 07-Jan-12

SBE19plus CONDUCTIVITY CALIBRATION DATA
PSS 1978: C(35,15,0) = 4.2914 Siemens/meter

COEFFICIENTS:

g = -9.958156e-001 CPcor = -9.5700e-008
h = 1.574233e-001 CTcor = 3.2500e-006
i = -5.789094e-004
j = 6.973901e-005

BATH TEMP (ITS-90)	BATH SAL (PSU)	BATH COND (Siemens/m)	INST FREQ (Hz)	INST COND (Siemens/m)	RESIDUAL (Siemens/m)
22.0000	0.0000	0.00000	2523.26	0.0000	0.00000
1.0522	34.9247	2.98888	5049.51	2.9889	0.00001
4.5393	34.9046	3.29577	5239.93	3.2958	0.00000
14.9999	34.8606	4.27646	5805.91	4.2764	-0.00003
18.5000	34.8509	4.62246	5992.56	4.6225	-0.00001
24.0000	34.8403	5.18180	6282.24	5.1818	0.00002
29.0000	34.8342	5.70492	6541.17	5.7050	0.00003
32.5000	34.8310	6.07826	6719.61	6.0782	-0.00003

f = INST FREQ / 1000.0

Conductivity = (g + hf² + if³ + jf⁴) / (1 + δt + εp) Siemens/meter

t = temperature[°C]; p = pressure[decibars]; δ = CTcor; ε = CPcor;

Residual = instrument conductivity - bath conductivity

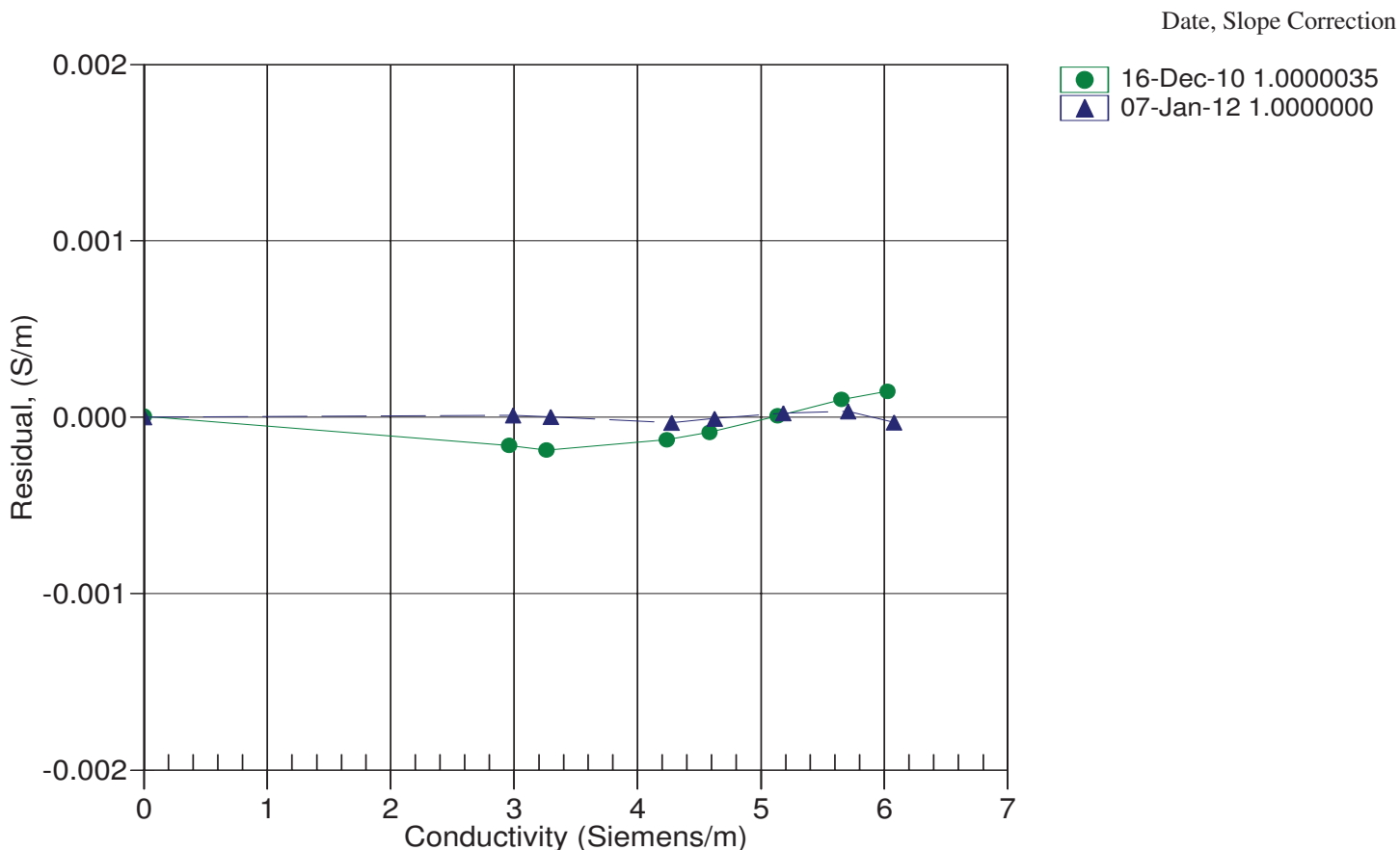



SEA-BIRD ELECTRONICS, INC.

13431 NE 20th St. Bellevue, Washington 98005 USA

Phone: (425) 643-9866 Fax: (425) 643-9954 www.seabird.com

Temperature Calibration Report

Customer:	Pacific Marine Center / NOAA		
Job Number:	67182	Date of Report:	1/9/2012
Model Number	SBE 19Plus	Serial Number:	19P50959-6122

Temperature sensors are normally calibrated 'as received', without adjustments, allowing a determination sensor drift. If the calibration identifies a problem, then a second calibration is performed after work is completed. The 'as received' calibration is not performed if the sensor is damaged or non-functional, or by customer request.

An 'as received' calibration certificate is provided, listing coefficients to convert sensor frequency to temperature. Users must choose whether the 'as received' calibration or the previous calibration better represents the sensor condition during deployment. In SEASOFT enter the chosen coefficients. The coefficient 'offset' allows a small correction for drift between calibrations (consult the SEASOFT manual). Calibration coefficients obtained after a repair apply only to subsequent data.

'AS RECEIVED CALIBRATION'

Performed Not Performed

Date:

Drift since last cal: Degrees Celsius/year

Comments:

'CALIBRATION AFTER REPAIR'

Performed Not Performed

Date:

Drift since Last cal: Degrees Celsius/year

Comments:

Sea-Bird Electronics, Inc.

13431 NE 20th Street, Bellevue, WA 98005-2010 USA

Phone: (+1) 425-643-9866 Fax (+1) 425-643-9954 Email: seabird@seabird.com

SENSOR SERIAL NUMBER: 6122
CALIBRATION DATE: 06-Jan-12

SBE19plus PRESSURE CALIBRATION DATA
870 psia S/N 2752080

COEFFICIENTS:

PA0 = -1.595168e-001	PTCA0 = 5.244075e+005
PA1 = 2.635889e-003	PTCA1 = -1.948655e+000
PA2 = 1.988748e-011	PTCA2 = -5.273420e-002
PTEMPA0 = -6.221592e+001	PTCB0 = 2.507825e+001
PTEMPA1 = 5.462283e+001	PTCB1 = -5.500000e-004
PTEMPA2 = -5.399299e-001	PTCB2 = 0.000000e+000

PRESSURE SPAN CALIBRATION

PRESSURE PSIA	INST OUTPUT	THERMISTOR OUTPUT	COMPUTED PRESSURE	ERROR %FSR
14.75	529997.0	1.5	14.75	-0.00
180.02	592632.0	1.6	180.02	0.00
360.01	660768.0	1.6	359.98	-0.00
530.01	725071.0	1.6	529.99	-0.00
719.99	796861.0	1.6	719.99	0.00
874.96	855352.0	1.6	874.94	-0.00
720.00	796880.0	1.6	720.04	0.00
530.04	725097.0	1.6	530.06	0.00
360.05	660792.0	1.6	360.05	0.00
180.07	592649.0	1.6	180.07	0.00
14.75	529999.0	1.6	14.76	0.00

THERMAL CORRECTION

TEMP ITS90	THERMISTOR OUTPUT	INST OUTPUT
32.50	1.76	530082.73
29.00	1.70	530102.94
24.00	1.60	530126.87
18.50	1.50	530149.57
15.00	1.43	530162.55
4.54	1.24	530187.58
1.05	1.17	530204.98

TEMP (ITS90)	SPAN (mV)
-5.00	25.08
35.00	25.06

$$y = \text{thermistor output}; t = PTEMPA0 + PTEMPA1 * y + PTEMPA2 * y^2$$

$$x = \text{pressure output} - PTCA0 - PTCA1 * t - PTCA2 * t^2$$

$$n = x * PTCB0 / (PTCB0 + PTCB1 * t + PTCB2 * t^2)$$

$$\text{pressure (psia)} = PA0 + PA1 * n + PA2 * n^2$$

Date, Avg Delta P %FS

06-Jan-12 0.00

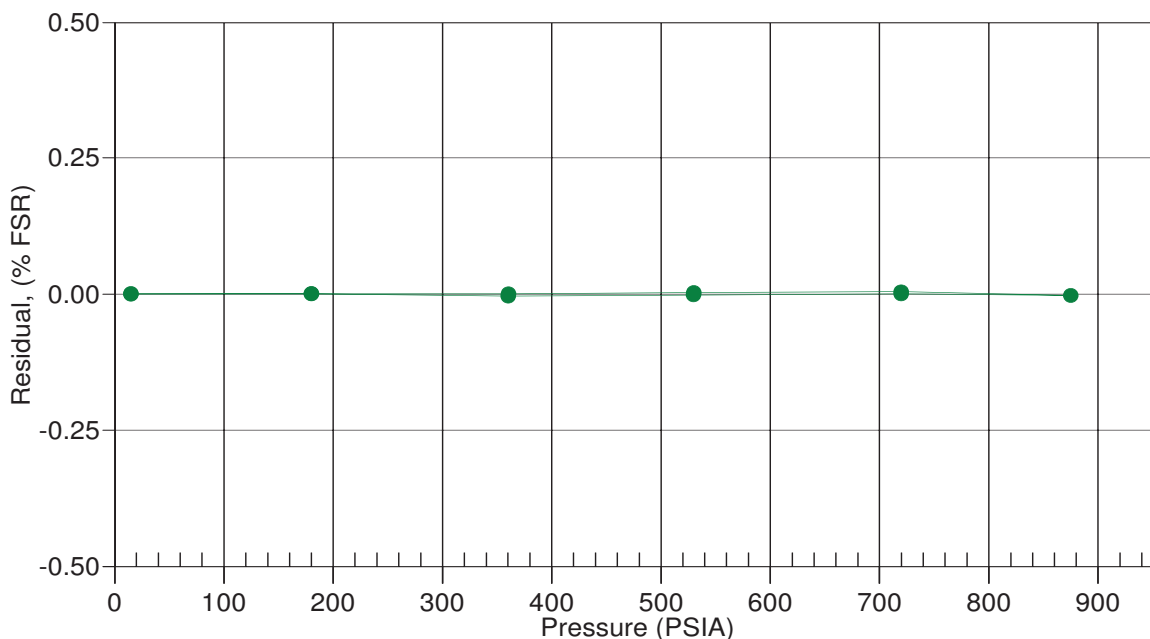



SEA-BIRD ELECTRONICS, INC.

13431 NE 20th St. Bellevue, Washington 98005 USA

Phone: (425) 643-9866 Fax: (425) 643-9954 www.seabird.com

Pressure Test Certificate

Customer Pacific Marine Center / NOAA

Job Number 67182

Date 1/5/2012

Technician JK

Serial Number 19P50959-6122

Low Pressure (PSI) 50 PSI

Time (Minutes) 15 Minutes

High Pressure (PSI) 500 PSI

Time (Minutes) 30 Minutes

Pass

Fail

Comments

Replaced the main piston "O"-Rings.

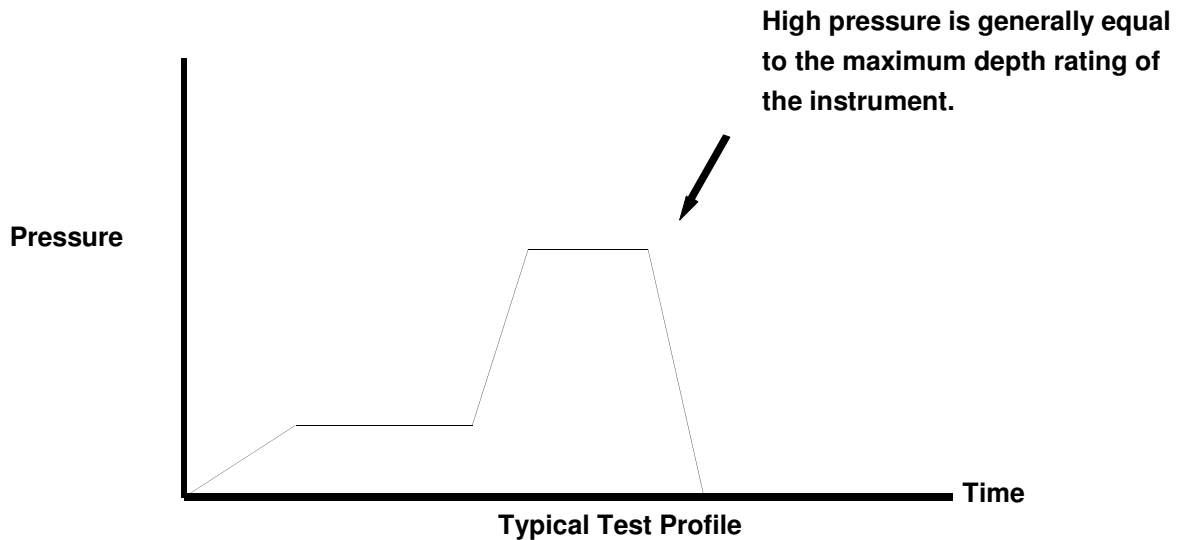



SVP Test and Calibration certificate

SVP Type :	SVP70
SVP Serial No.	4008077

Date of issue :	01-04-2009
-----------------	------------

Functionality Test : Sign : _____

Temperature Calibration :	Hart 1504 s/n A6B554 & Thermistor s/n 3014
Point 1:	4.6 °C
Point 2:	16.5 °C
Point 3:	25.5 °C
Pressure Calibration :	Custom Built Tank (TestUnit ASF150 Ser# 41-10-0007-R03)
Point 1:	0 Bar
Point 2:	301.7 Bar
Point 3:	603.6 Bar

RMS Speed of Sound Errors

Temperature Validation :	0.0033 m/s
Pressure Validation :	0.0845 m/s

Calibration Completed : Sign : _____

Final Function Test : Sign : _____

QA Signature : Inits : _____





SVP Test and Calibration certificate

SVP Type : SVP70
SVP Serial No. 4111053

Date of issue : 06-03-2012

Temperature Calibration : Hart 1504 s/n A6B554 & Thermistor s/n 3014
Point 1: 4.6 °C
Point 2: 16.5 °C
Point 3: 25.5 °C
Pressure Calibration : Custom Built Tank (TestUnit ASF150 Ser# 41-10-0007-R03)
Point 1: 0 Bar
Point 2: 300.5 Bar
Point 3: 600.7 Bar

RMS Speed of Sound Errors
Temperature Validation : 0.0299 m/s
Pressure Validation : 0.1419 m/s

Calibration & Final Function Test : Sign : Jind Petersen

QA Signature : Inits : Oskofar
2012.03.09



RESON A/S, Fabriksvängen 13, DK-3550 Slangerup
Fax: +45 4738 0066, Phone: +45 4738 0022



SVP Test and Calibration certificate

SVP Type : SVP71
SVP Serial No. 2008016

Date of issue : 08-10-2009

Functionality Test : Sign : Michael Hansen

Temperature Calibration : Hart 1504 s/n A6B554 & Thermistor s/n 3014
Point 1: 4.6 °C
Point 2: 16.6 °C
Point 3: 25.5 °C
Pressure Calibration : Custom Built Tank (TestUnit ASF150 Ser# 41-10-0007-R03)
Point 1: 0 Bar
Point 2: 100.3 Bar
Point 3: 206.2 Bar

RMS Speed of Sound Errors

Temperature Validation : 0.0080 m/s
Pressure Validation : 0.1071 m/s

Calibration Completed : Sign : Michael Hansen

Final Function Test : Sign : Michael Hansen

QA Signature : Inits : JCHR 

RESON A/S
Jegstrupvej 54
8361 Hasselager
Tel: +45 86 28 82 44



SVP Test and Calibration certificate

SVP Type : SVP71
SVP Serial No. 2008017

Date of issue : 11-06-2009

Functionality Test : Sign : Jim H Nielsen

Temperature Calibration :	Hart 1504 s/n A6B554 & Thermistor s/n 3014
Point 1:	4.6 °C
Point 2:	16.5 °C
Point 3:	25.5 °C
Pressure Calibration :	Custom Built Tank (TestUnit ASF150 Ser# 41-10-0007-R03)
Point 1:	0 Bar
Point 2:	100 Bar
Point 3:	204.6 Bar

RMS Speed of Sound Errors

Temperature Validation : 0.0126 m/s
Pressure Validation : 0.0669 m/s

Calibration Completed : Sign : Jim H Nielsen

Final Function Test : Sign : Jim H Nielsen

QA Signature : Inits : Michael H.



RESON A/S
Jegstrupvej 54
8361 Hasselager
Tel: +45 86 28 82 44



SVP Test and Calibration certificate

SVP Type : SVP71
SVP Serial No. 2008027

Date of issue : 04-11-2009

Functionality Test : Sign : Jim H Nielsen

Temperature Calibration : Hart 1504 s/n A6B554 & Thermistor s/n 3014
Point 1: 4.6 °C
Point 2: 16.5 °C
Point 3: 25.5 °C
Pressure Calibration : Custom Built Tank (TestUnit ASF150 Ser# 41-10-0007-R03)
Point 1: 0 Bar
Point 2: 102 Bar
Point 3: 206.2 Bar

RMS Speed of Sound Errors

Temperature Validation : 0.0122 m/s
Pressure Validation : 0.0250 m/s

Calibration Completed : Sign : Jim H Nielsen

Final Function Test : Sign : Jim H Nielsen

QA Signature : Inits : Michael Bo-

RESON A/S
Jegstrupvej 54
8361 Hasselager
Tel: +45 86 28 82 44



SVP Test and Calibration certificate

SVP Type : SVP71
SVP Serial No. 2008038

Date of issue : 14-07-2009

Functionality Test : Sign : Michael Hanson

Temperature Calibration :	Hart 1504 s/n A6B554 & Thermistor s/n 3014
Point 1:	4.6 °C
Point 2:	16.6 °C
Point 3:	25.5 °C
Pressure Calibration :	Custom Built Tank (TestUnit ASF150 Ser# 41-10-0007-R03)
Point 1:	0 Bar
Point 2:	100.1 Bar
Point 3:	206.4 Bar

RMS Speed of Sound Errors

Temperature Validation :
Pressure Validation :

0.0034 m/s
0.1263 m/s

Calibration Completed : Sign : Michael Hanson

Final Function Test : Sign : Michael Hanson

QA Signature : Inits : JHN



RESON A/S
Jegstrupvej 54
8361 Hasselager
Tel: +45 86 28 82 44

Appendix II

Vessel Reports, Offsets, and Diagrams

Launch 2805

1. Offsets
2. Patch Test
3. POS MV GAMS Calibration
4. Dynamic Draft

Launch 2808

1. Offsets
2. Patch Test
3. POS MV GAMS Calibration
4. Dynamic Draft

S220

1. Offsets
2. Static Draft
3. Vessel Report
 - a. Survey Report 3/2009
 - b. Stability Report 7/2004
 - c. Survey Report 9/2003
4. Patch Test
5. POS MV GAMS Calibration
6. Dynamic Draft

Coordinate Systems Utilized in Vessel Offsets

2805 Offsets and Measurements - Summary

Measurement aka Coord. Sys.	IMU to RP* Caris	IMU to 7125 SWATH1 x,y,z & MRU to Trans Caris	Port Ant to 7125 Nav to Trans x,y,z Caris	RP* to Waterline Caris	Port Ant to Stbd Ant Scalar Distance	IMU to Port Ant Caris / Pos/Mv	IMU to Heave Caris / Pos/Mv
x	0.000	0.004	0.686	n/a	1.447	-0.682	0.000
y	0.000	0.245	1.051	n/a		-0.806	0.000
z	0.000	0.482	3.656	-0.097		-3.174	0.000

*IMU is Reference Point

-0.111 (2010 used for K5K)

Vessel Offsets for 2805 7125 are derived from the NGS Survey, January 2010, Trimble Equipment Specs, and 2011 and 2010 Measured Values.

Calculations

Coord. Sys./ Source	IMU to 7125	Port Ant to 7125	RP to Waterline	Port Ant to Stbd Ant	IMU to Port Ant	IMU to Heave
NGS	IMU (m) x 0.00000 y 0.00000 z 0.00000	IMU to x -0.68217 Port Ant (m) y -0.80598 (calculated) z 3.17407	RP to Waterline (m) (waterline z 0.097 worksheet)	IMU to x -0.68217 Port Ant (m) y -0.80598 (calculated) z 3.17407	IMU (m) x 0.00000 y 0.00000 z 0.00000	IMU (m) x 0.00000 y 0.00000 z 0.00000
MBES RP Rcvr - Phase Center	x 0.00401 y 0.24503 z -0.48191	IMU to 7125 x 0.00401 Phase Ctr y 0.24503 (calculated) z -0.48191	2010 RP to Waterline (m) (waterline z 0.111 worksheet)	IMU (m) x, y, z 0.00000 Top of Stbd Ant (m) x 0.76454 y -0.80778 z 3.14528	Top of Port Ant (m) x -0.68217 y -0.80598 z 3.16277	Heave Pt (m) x 0.00000 (by design) y 0.00000 z 0.00000
				Base to top of Stbd Ant (measured) (m) z 0.073	Base to top of Port Ant (measured) (m) z 0.073	
				Bottom of Stbd Ant (calculated) (m) z 3.07228	Bottom of Port Ant (calculated) (m) z 3.08977	
				Base to Phase Cntr of Stbd Ant (eqp spc) (m) z 0.0843	Base to Phase Cntr of Port Ant (eqp spc) (m) z 0.0843	
Coord. Sys. NGS	IMU to 7125 x 0.00401 Phase Ctr y 0.24503 z -0.48191	Port Ant to 7125 x 0.68618 y 1.05101 z -3.65598	RP to Waterline x n/a y n/a z 0.097	Port Ant to Stbd Ant Scalar Distance 1.4468	IMU to Port Ant x -0.68217 y -0.80598 z 3.17407	IMU to Heave x 0.00000 y 0.00000 z 0.00000
Coord. Sys. CARIS	x 0.00401 y 0.24503 z 0.48191	Coord. Sys. CARIS x 0.68618 y 1.05101 z 3.65598	Coord. Sys. CARIS x n/a y n/a z -0.097		Coord. Sys. Pos/Mv x -0.80598 y -0.68217 z -3.17407	Coord. Sys. Pos/Mv x 0.00000 y 0.00000 z 0.00000

2012 2011 Measured Values

Measurement aka	IMU to RP*	IMU to K5K	IMU to Tow PT K5K
Coord. Sys.	Caris	Caris	Caris
x	0.000	0.534	0.609
y	0.000	0.845	-5.525
z	0.000	0.772	-2.186

*IMU is Reference Point

Vessel Offsets for 2805 K5K are derived from the NGS Survey, January 2010, Trimble Equipment Specs, and

Calculations

Coord. Sys./ Source	IMU to K5K	IMU to Tow PT K5K
NGS	IMU (m)	IMU (m)
	x 0.00000	x 0.00000
	y 0.00000	y 0.00000
	z 0.00000	z 0.00000
	KEEL FORE BM	Centerline Stern BM
	x -0.00202	x -0.01735
	y 0.44007	y -4.04803
	z -0.6141	z 0.67574
	KEEL FORE BM to K5K	CSBM to Tow PT
	Rcvr - Phase	
	x 0.536	x 0.626
	Center	y -1.477
	(measured)	z 1.510
	z -0.158	
Coord. Sys.	IMU to K5K	IMU to Tow PT K5K
NGS	IMU to K5K	IMU to Tow PT K5K
	x 0.53398	x 0.60865
	Phase Ctr	y -5.52503
	y 0.84507	z 2.18574
	z -0.77210	
Coord. Sys.		Coord. Sys.
CARIS	x 0.53398	CARIS
	y 0.84507	y -5.52503
	z 0.77210	z -2.18574

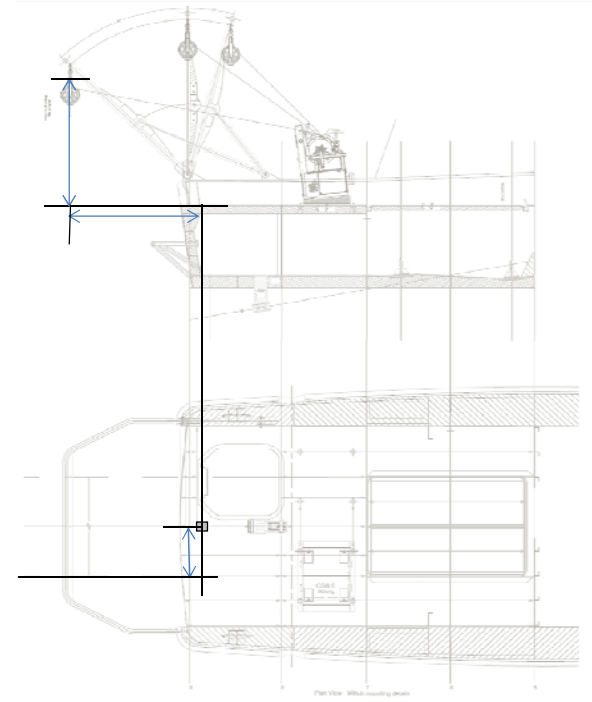

Description of Offsets for Launch 2805

All Values Shown are in CARIS Coordinates

The Ship Reference Frame (SRF) for Launch 2805 was based from the IMU reference point as the 0,0,0 point. Physical locations were measured with x,y,z offsets from this point. These locations were used to calculate offsets of items with respect to each other, as described for each offset.

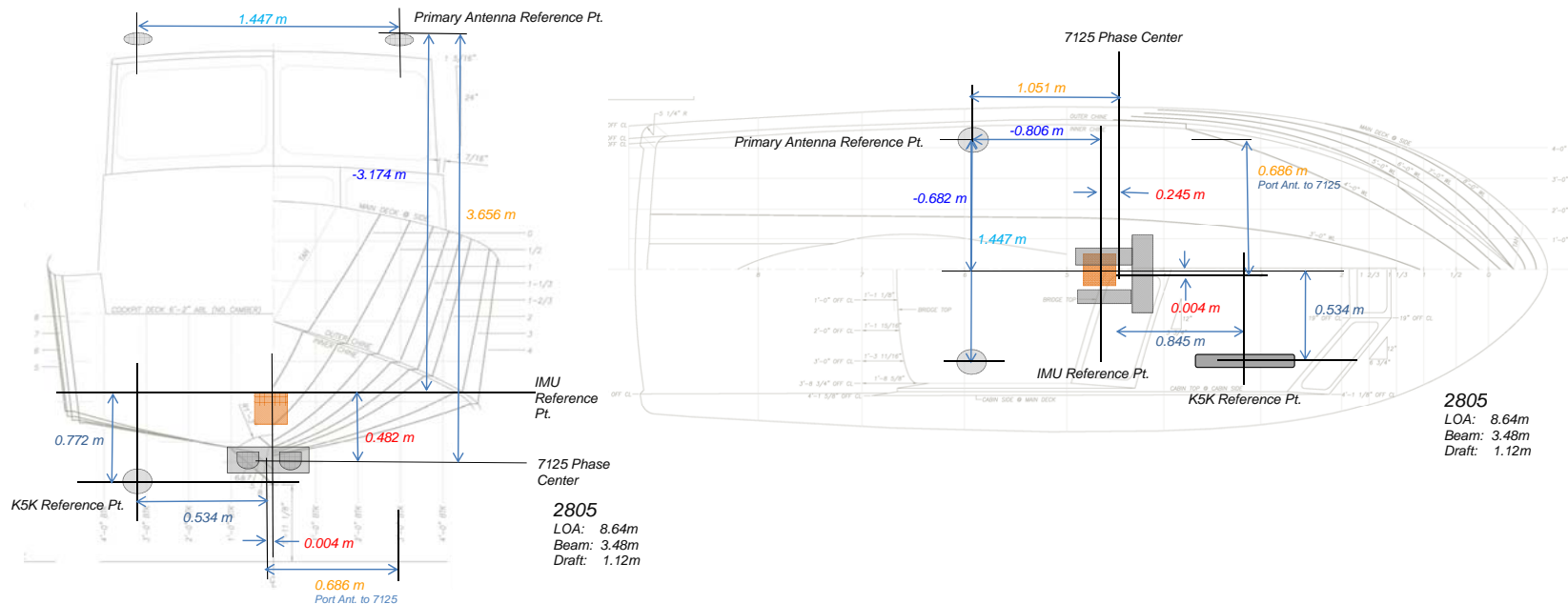

IMU to 7125		
x	y	z
0.004	0.245	0.482

The physical positions of the IMU and the receiver phase center of the 7125 were measured during the NGS survey. These physical measurements were taken while the launch was secured on the pier and thought to be as level as possible. The measured values for the IMU and MB were taken directly for the report. The difference is the offset from the IMU to the phase center of the 7125 which was then transposed from the NGS to the CARIS coordinate system.

Port Ant to 7125		
x	y	z
0.686	1.051	3.656

The values were calculated by subtracting the physical height of the Port Antenna to the IMU x, y, z values from the respective values of the IMU to the 7125. The calculated values were then transposed from the NGS to the CARIS coordinate system.

RP to Waterline		
x	y	z
N/A	N/A	-0.097

The average vertical distance from Port Benchmark to waterline and the Starboard Benchmark to the waterline were measured by FAIRWEATHER personnel using a steel tape and bubble level. These values were combined with the Z value of the Benchmarks to the RP/IMU to get an average for the waterline to RP. The Waterline Measurement value is in NGS coordinates initially and is converted to CARIS coordinates.

Port Ant to Stbd Ant
Scalar Distance
1.447

The location of the phase center of the port and starboard POS/MV antennas were surveyed by NGS. The z-values were adjusted to the phase center. Then the scalar distance between the phase centers was calculated.

IMU to Port Antenna		
x	y	z
-0.682	-0.806	-3.174

The location of the IMU and the location of the top of port antenna were surveyed by NGS. The z-value of the antenna was calculated by subtracting the height of the antenna and then adding the value from the base of the antenna to the phase center of the antenna. The calculation results were then transposed from the NGS to the CARIS coordinate system.

IMU to Heave		
x	y	z
0.000	0.000	0.000

The Heave Point is assumed to coincide with the IMU location.

IMU to K5K		
x	y	z
0.534	0.845	0.772

The location of the IMU and the location of the forward keel benchmark were surveyed by NGS. BM to K5K were measured by FAIRWEATHER personnel using a steel tape and bubble level.

Waterline Measurements

Measuring Party: **ENS Wilson, ST Francksen, ENS Flowers**
2805

Waterline measurements should be negative and cm!

Fill in Yellow squares only!

Date: **3/17/2011**

Fuel Level: **101 Gallon**

Draft Tube:

Port-to-Stbd Z-difference

Theoretical	Actual	Error
0.0329	-0.0170	-0.0498

RP to WL Average (m)

0.083

2805		
	Port Benchmark to Waterline	Stbd Benchmark to Waterline
Measure 1	-98.1	-100.3
Measure 2	-95.2	-98.1
Measure 3	-96.8	-96.8
Avg (cm)	-96.70	-98.40
Avg (m)	-0.9670	-0.9840
Stdev	0.01453	0.01769
BM Z-value (m)*	1.07535	1.04250
BM to WL (m)	0.108	0.059
Individual measurement	0.09435	0.03950
	0.12335	0.06150
StDev for TPU xls (of 6 #'s)	0.031	0.10735
		0.07450

Measuring Party: **ENS Wilson, ST Francksen, LT Jaskoski, SS Abraham**
 Waterline measurements should be negative and cm!

Date: **3/25/2011**

Fuel Level: **68.9 Gallon**

Draft Tube:

Port-to-Stbd Z-difference

Theoretical	Actual	Error
0.0329	0.0010	-0.0319

RP to WL Average (m)

0.097

(Add this value to VSSL_Offsets & Measurements_20XX.xls)

2805		
	Port Benchmark to Waterline	Stbd Benchmark to Waterline
Measure 1	-96.5	-95.9
Measure 2	-96.5	-95.7
Measure 3	-95.7	-96.8
Avg (cm)	-96.23	-96.13
Avg (m)	-0.9623	-0.9613
Stdev	0.00462	0.00586
BM Z-value (m)	1.07535	1.04250
BM to WL (m)	0.113016667	0.081
Individual measurement	0.11035	0.08350
	0.11035	0.08550
StDev for TPU xls (of 6 #'s)	0.018	0.11835
		0.07450

Utilized in Offsets and Measurements and TPU spreadsheet

Measuring Party: **Morgan, Loy, Pfundt**

Waterline measurements should be negative and cm!

Date: **4/6/2011**

Fuel Level: **30 gallons**

Draft Tube:

Port-to-Stbd Z-difference

Theoretical	Actual	Error
0.0329	-0.0467	-0.0795

RP to WL Average (m)

0.091

2805		
	Port Benchmark to Waterline	Stbd Benchmark to Waterline
Measure 1	-94.2	-100.7
Measure 2	-94.6	-98.1
Measure 3	-94.5	-98.5
Avg (cm)	-94.43	-99.10
Avg (m)	-0.9443	-0.9910
Stdev	0.00208	0.01400
BM Z-value (m)	1.07535	1.04250
BM to WL (m)	0.131	0.051
Individual measurement	0.13335	0.03550
	0.12935	0.06150
StDev for TPU xls (of 6 #'s)	0.044464	0.13035
		0.05750

US DEPARTMENT OF COMMERCE
NATIONAL OCEANIC & ATMOSPHERIC ADMINISTRATION
NATIONAL OCEAN SERVICE
NATIONAL GEODETIC SURVEY
GEODETIC SERVICES DIVISION
INSTRUMENTATION & METHODOLOGIES BRANCH

**NOAA SURVEY VESSEL 2805
POS MV COMPONENTS SPATIAL RELATIONSHIP
SURVEY
FIELD REPORT**

Kendall L. Fancher
January, 2010



**NOAA SURVEY VESSEL 2805
POS MV COMPONENTS SPATIAL RELATIONSHIP SURVEY**

PURPOSE

The primary purpose of the survey was to precisely determine the spatial relationship between various hydrographic surveying sensors, launch bench marks and the components of a POS MV navigation system aboard the NOAA survey vessel 2805.

PROJECT DETAILS

This survey was conducted in Seattle, WA at the NOAA Western Center on the 26th of January, 2010. The weather was sunny early then cloudy with temperatures in the 40s to 50s. For this survey, the vessel was on blocks, supported by boat jacks. The vessel was reported to have been leveled relative to the IMU.

INSTRUMENTATION

A Leica TDA5005 precision total station was used to make all measurements.

Technical Data:

Standard Deviation	
Horizontal angle	0.5 seconds
Vertical angle	0.5 seconds
Distance measurement	1mm + 1ppm

Leica precision prisms were used as sighting targets. Prisms were configured to have a zero mm offset.

PERSONNEL

Kendall Fancher NOAA/NOS/NGS/GSD/I&M BRANCH
(540) 373-1243
kendall.fancher@noaa.gov

Dennis Lokken NOAA/NOS/NGS/GSD/I&M BRANCH
(540) 373-1243
dennis.lokken@noaa.gov

NOAA SURVEY VESSEL 2805
POS MV COMPONENTS SPATIAL RELATIONSHIP SURVEY

DEFINITION OF THE REFERENCE FRAME

For this survey, data was collected in a 3-D right handed Cartesian coordinate system. The origin of this coordinate system is defined as the center of the IMU target. The Y (Northing) axis is parallel to the centerline of the launch and is positive towards the bow of the launch. The X (Easting) axis is perpendicular to the Y axis and is positive towards the starboard side of the launch. The Z (Elevation) axis is perpendicular to the XY plane and is positive towards the top of the launch. The coordinates of the points established this survey are reported in this coordinate system and are provided in Appendix A.

SURVEY METHODOLOGY

Four temporary control points, (1, 2, 3, and 4), were established around the vessel such that every point to be positioned on the launch could be observed from at least two separate locations.

Coordinates of 100.000N, 100.000E, and 100.000U were assumed for temporary control point 1. A distance and height difference were measured between control points 1 and 2. Temporary control point 2 was assumed to have an Easting of 100.000. The measured distance between these two points was used to determine the Northing for temporary control point 2. The height difference between the two points was used to determine the Up component for control point 2.

Control point 1 was occupied and control point 2 was observed to initialize the instrument. After initialization, control point 4 and all visible points to be observed on the launch were observed in both direct and reverse. The stability of the instrument setup was checked at conclusion of the data set collection by checking back to temporary control point 2.

Control point 2 was occupied and control point 1 was observed to initialize the instrument. After initialization, control point 3 and all visible points to be observed on the launch were observed in both direct and reverse. The stability of the instrument setup was checked at conclusion of the data set collection by checking back to temporary control point 1.

Control point 3 was occupied and control point 2 was observed to initialize the instrument. After initialization, control point 4 and all visible points to be observed on the launch were observed in both direct and reverse. The stability of the instrument setup was checked at conclusion of the data set collection by checking back to temporary control point 2.

NOAA SURVEY VESSEL 2805 POS MV COMPONENTS SPATIAL RELATIONSHIP SURVEY

Control point 4 was occupied and control point 3 was observed to initialize the instrument. After initialization, all visible points to be observed on the launch were observed in both direct and reverse. Control point 1 was also observed in order to evaluate the accuracy of the traverse. Inverse computations between the original and observed control point yielded a horizontal accuracy, or traverse closure of 0.000m and a vertical accuracy of 0.000m. The stability of the instrument setup was checked at conclusion of the data set collection by checking back to temporary control point 2.

Inverses were computed between the two positions determined for all points surveyed to evaluate their accuracy relative to the temporary control network. Inverse reports are included in appendix B.

The reference frame was rotated using CENTERLINE STERN BM (CLS) as the point of rotation. A zero degree azimuth was used during the rotation from CLS to CENTERLINE BOW BM (BMB). The reference frame was then translated to relocate the origin of the reference frame to the IMU.

DISCUSSION

The positions given for the POS GPS antennas (Zephyr Model II p/n 57970-00) are to the top center of the antenna. To correct the Z value provided in this report for each antenna to the electronic phase center, I recommend the following steps be taken;

- 1) Determine the physical height of the GPS antenna. This information is probably located on the antenna or with equipment documentation.
- 2) Investigate to find the electronic phase center offset of the antenna. This information is probably located on the antenna or with equipment documentation. This value may also be available at the NGS website for antenna modeling.
- 3) Subtract the total height of the antenna from the Z value for each antenna. This will give you a Z value for the antenna ARP (antenna reference point)
- 4) Then add to this value the electronic phase center offset value appropriate for the antenna model.



NOAA SURVEY VESSEL 2805 POS MV COMPONENTS SPATIAL RELATIONSHIP SURVEY

Two reference points (MBF and MBA) were positioned in order to facilitate future measurements to the Multi-Beam sensor by launch personnel. These reference points are punch marks set along the center of the keel, at the locations described in the image at right.



A point on the Multi-Beam transducer (MB) was measured directly this survey. The measured point was at the center of the bottom of the transducer. No mark was left to indicate the measured point.

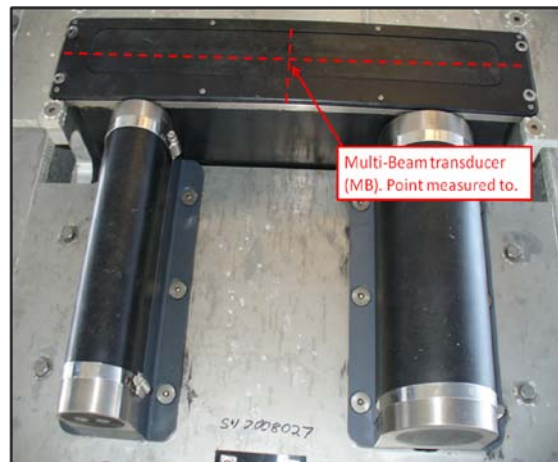

The point positioned for the Inertial Motion Unit (IMU) this survey was the center of the target affixed to the top of the unit. Additionally, a reference mark (IMUR) was established on the plate the IMU is attached to at a point where two scribed lines intersect, forward of the IMU.

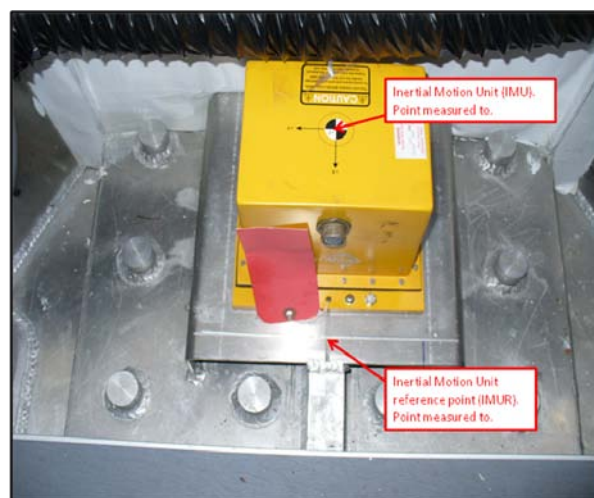

**NOAA SURVEY VESSEL 2805
POS MV COMPONENTS SPATIAL RELATIONSHIP SURVEY**

STATION LISTING

BMB-	CENTERLINE BOW BM The center of a cross mark inscribed into the top of a square metal flange, welded to the deck, along the centerline and near the bow of the launch.
CLS-	CENTERLINE STERN BM The center of a cross mark inscribed into the top of a square metal flange, welded to the deck, along the centerline and near the stern of the launch.
BMC-	CENTERLINE CAB BM The center of a cross mark inscribed into the top of a square metal flange, welded to the top of the cab, along the centerline of the launch.
BMP-	PORT SIDE BM The center of a cross mark inscribed into the top of a square metal flange, welded to the top of the deck, near the middle of and along the port side of the launch.
BMS-	STARBOARD SIDE BM The center of a cross mark inscribed into the top of a square metal flange, welded to the top of the deck, near the middle of and along the starboard side of the launch.
MBF-	KEEL BM A punch mark set along the bottom center of the keel, fore of the multi-beam transducer, 0.030 m from a point where the keel makes a 90 degree angle upwards.
MBA-	KEEL BM A punch mark set along the bottom center of the keel, aft of the multi-beam transducer, 0.030 m from a point where the keel makes a 90 degree angle upwards.
IMU-	IMU TARGET Center of a target affixed to the top of the IMU housing.
IMUR-	IMU REFERENCE BM The intersection of two scribed lines atop a metal support plate for the IMU and forward of the IMU.
GPSP-	PORT SIDE GPS ANTENNA REFERENCE POINT The top center of the port side GPS antenna for the POS system.
GPSS-	STARBOARD GPS ANTENNA REFERENCE POINT The top center of the starboard side GPS antenna for the POS system.
MB-	MULTI-BEAM REFERENCE POINT The physical bottom center of the Multi-Beam transducer.

Appendix A

Coordinate Report Launch 2805

<i>Pt Name</i>	<i>North(Y)</i>	<i>East(X)</i>	<i>Elev.(Z)</i>	<i>ID</i>
IMU Target	0.00000	0.00000	0.00000	IMU
IMU Reference BM	0.13270	-0.00348	-0.16937	IMUR
Centerline Stern BM	-4.04803	0.01735	0.67574	CLS
Centerline Bow BM	3.46914	0.01735	1.39751	BMB
Portside GPS Ant. Ref. Point	-0.80598	-0.68217	3.16277	GPSP
Starboard GPS Ant. Ref. Point	-0.80778	0.76454	3.14528	GPSS
Multi-Beam Ref.Point	0.24503	0.00401	-0.48191	MB
Keel BM	0.44007	-0.00202	-0.61410	MBF
Keel BM	-0.22895	-0.00227	-0.53363	MBA
Port Side BM	0.10603	-1.42637	1.07535	BMP
Starboard Side BM	0.10926	1.45859	1.04250	BMS
Centerline Cab BM	-0.19024	0.03192	2.65903	BMC

Units = meters

Appendix B

Point to Point Inverse Launch 2805

<i>Pt. 1</i>	<i>Pt. 2</i>	<i>Dist.</i>	<i>Northing</i>	<i>Easting</i>	<i>Elevation</i>	<i>ID</i>
18	31	0.004	-0.003	0.003	-0.00141	BMC
9	29	0.001	0.001	- 0.001	0.00051	BMP
39	49	0.003	-0.003	0.001	-0.00063	BMS
8	48	0.001	-0.001	-0.001	0.00016	CLS
10	30	0.002	-0.001	0.002	0.00033	GPSP
11	41	0.000	0.000	0.000	0.00034	GPSS
16	53	0.001	0.000	0.001	0.00024	IMU
17	54	0.002	0.000	0.002	0.00029	IMUR
4	46	0.006	0.005	0.002	-0.00018	MB
5	47	0.001	0.000	0.001	0.00016	MBA
3	45	0.002	0.001	0.001	-0.00017	MBF

Units = meters

FAIRWEATHER

Multibeam Echosounder Calibration

Launch 2805 200kHz

Vessel

4/14/2012	105	Shillshoal
Date	Dn	Local Area

SST Francksen, ST Bravo, AST Robinson

Calibrating Hydrographer(s)

7125	Hull Mounted	2009
MBES System	MBES System Location	Date of most recent EED/Factory Check

1812027	
Sonar Serial Number	Processing Unit Serial Number

Fixed Hull Mount	1/26/2012
Sonar Mounting Configuration	Date of current offset measurement/verification

Applanix POS/MV S/N:3628 IMU S/N:294	3/13/2012
Description of Positioning System	Date of most recent positioning system calibration

Acquisition Log

4/14/2012	105	Shillshoal	1' seas, wind 5kts, MCLR
Date	Dn	Local Area	Wx

	10 to 50
Bottom Type	Approximate Water Depth

Brooksk, Franksen, Bravo, Robinson

Personnel on board

Comments

2012_105_2805.000

POSMV Filename(s)

2012_105_180653	1806	47/40/25.1N	122/25/22.24W	26.06	
SV Cast #1 filename	UTC Time	Lat	Lon	Depth	Ext. Depth

2012_105_193159	1931	47/40/25.1N	122/25/22.24W	24	
SV Cast #2 filename	UTC Time	Lat	Lon	Depth	Ext. Depth

2012_105_222342	2223	47/40/25.1N	122/25/22.24W	25.09	
SV Cast #3 filename	UTC Time	Lat	Lon	Depth	Ext. Depth

view parallel to track, one line with induced roll (outerbeam) or same lines bounded slope (nadir)
[same direction, different speed]

NAV TIME LATENCY

SV Cast #	hsx Line Filename	Heading	Speed (kts)	Remarks
	2012M_1052030.hsx	130	4.0	
	2012M_1052033.hsx	303	4.0	
	2012M_1052035.hsx	125	8.0	
	2012M_1052038.hsx	305	8.0	
	2012M_1052042.hsx	135	8.0	

PITCH view parallel to track, same line (at nadir) [opposite direction, same speed]

SV Cast #	XTF Line Filename	Heading	Speed (kts)	Remarks
	2012M_1052047.hsx	303	4.0	
	2012M_1052050.hsx	128	4.0	
	2012M_1052052.hsx	305	4.0	
	2012M_1052054.hsx	128	4.0	
	2012M_1052057.hsx	305	4.0	

HEADING/YAW view parallel to track, offset lines (outerbeams) [opposite direction, same speed]

SV Cast #	XTF Line Filename	Heading	Speed (kts)	Remarks
	2012M_1052100.hsx	140	4.0	
	2012M_1052102.hsx	303	4.0	
	2012M_1052104.hsx	140	4.0	
	2012M_1052105.hsx	302	4.0	
	2012M_1052107.hsx	135	4.0	
	2012M_1052109.hsx	302	4.0	
	2012M_1052112.hsx	135	4.0	

ROLL view across track, same line [opposite direction, same speed]

SV Cast #	XTF Line Filename	Heading	Speed (kts)	Remarks
	2012M_1052116	217	4.0	induced roll
	2012M_1052120	119	4.0	induced roll
	2012M_1052124	217	4.0	no induced roll

Processing Log

4/14/2012 | 105 | CST Beduhn, ENS Madsen

Date Dn Personnel

- Data converted --> HDCS_Data in CARIS
- TrueHeave applied 2012_105_2805_CONCAT.000.fixed
- SVP applied 2012_105_2805.svp
- Tide applied

Zone file _____

Lines merged

Data cleaned to remove gross fliers

Compute correctors in this order

1. Precise Timing 2. Pitch bias 3. Heading bias 4. Roll bias

Do not enter/apply correctors until all evaluations are complete and analyzed.

PATCH TEST RESULTS/CORRECTORS

Evaluators	Latency (sec)	Pitch (deg)	Roll (deg)	Yaw (deg)
Beduhn	0.00	-0.89	-0.41	0.77
Zacharias	0.00	-0.90	-0.35	1.29
Loy	0.00	-1.20	-0.34	1.00
MacDonald	0.00	-0.71	-0.40	0.70
Averages	0.00	-0.93	-0.38	0.94
Standard Deviation	0.00	0.20	0.04	0.27
FINAL VALUES	0.00	-0.93	-0.38	0.94

Final Values based on _____

Resulting HVF File Name FA_2805_200kHz_7125_256bms_2012.hvf

MRU Align StdDev gyro 0.27 Value from standard deviation of Heading offset values
 MRU Align StdDev Roll/Pitch 0.12 Value from averaged standard deviations of pitch and roll offset values

NARRATIVE

- HVF Hydrographic Vessel File created or updated with current offsets

Name: Tami Beduhn

Date: 4/15/2012

FAIRWEATHER

Multibeam Echosounder Calibration

Launch 2805 400kHz

Vessel

4/14/2012	105	Shillshoal
Date	Dn	Local Area

SST Francksen, ST Bravo, AST Robinson

Calibrating Hydrographer(s)

7125	Hull Mounted	2009
MBES System	MBES System Location	Date of most recent EED/Factory Check

1812027	
Sonar Serial Number	Processing Unit Serial Number

Fixed Hull Mount	1/26/2010
Sonar Mounting Configuration	Date of current offset measurement/verification

Applanix POS/MV S/N:3628 IMU S/N:294	3/13/2012
Description of Positioning System	Date of most recent positioning system calibration

Acquisition Log

4/14/2012	105	Shillshoal	1' seas, wind 5kts, MCLR
Date	Dn	Local Area	Wx

	10 to 50
Bottom Type	Approximate Water Depth

Brooks, Franksen, Bravo, Robinson

Personnel on board

Comments

2012_105_2805.000

POSMV Filename(s)

2012_105_180653	1806	47/40/25.1N	122/25/22.24W	26.06	
SV Cast #1 filename	UTC Time	Lat	Lon	Depth	Ext. Depth

2012_105_193159	1931	47/40/25.1N	122/25/22.24W	24	
SV Cast #2 filename	UTC Time	Lat	Lon	Depth	Ext. Depth

2012_105_222342	2223	47/40/25.1N	122/25/22.24W	25.09	
SV Cast #3 filename	UTC Time	Lat	Lon	Depth	Ext. Depth

view parallel to track, one line with induced roll (outerbeam) or same lines bounded slope (nadir)
[same direction, different speed]

NAV TIME LATENCY

SV Cast #	hsx Line Filename	Heading	Speed (kts)	Remarks
	2012M_1052135.hsx	142	4.0	
	2012M_1052138.hsx	303	4.0	
	2012M_1052140.hsx	130	8.0	
	2012M_1052141.hsx	306	8.0	
	2012M_1052143.hsx	130	7.6	
	2012M_1052144.hsx	305	4.0	

PITCH view parallel to track, same line (at nadir) [opposite direction, same speed]

SV Cast #	XTF Line Filename	Heading	Speed (kts)	Remarks
	2012M_1052204.hsx	138	4.0	
	2012M_1052205.hsx	305	4.0	
	2012M_1052208.hsx	140	4.0	
	2012M_1052209.hsx	303	4.0	

HEADING/YAW view parallel to track, offset lines (outerbeams) [opposite direction, same speed]

SV Cast #	XTF Line Filename	Heading	Speed (kts)	Remarks
	2012M_1052148.hsx	306	4.0	
	2012M_1052150.hsx	132	4.0	
	2012M_1052152.hsx	306	4.0	
	2012M_1052146.hsx	135	4.0	
	2012M_1052156.hsx	143	4.0	
	2012M_1052158.hsx	135	4.0	

ROLL view across track, same line [opposite direction, same speed]

SV Cast #	XTF Line Filename	Heading	Speed (kts)	Remarks
	2012M_1052211.hsx	240	4.0	induced roll
	2012M_1052215.hsx	118	4.0	induced roll
	2012M_1052219.hsx	282	4.0	not induced roll

Processing Log

4/14/2012 | 105 | CST Beduhn, ENS Madsen

Date Dn Personnel

- Data converted --> HDCS_Data in CARIS
- TrueHeave applied 2012_105_2805_CONCAT.000.fixed
- SVP applied 2012_105_2805.svp
- Tide applied

Zone file _____

Lines merged

Data cleaned to remove gross fliers

Compute correctors in this order

1. Precise Timing 2. Pitch bias 3. Heading bias 4. Roll bias

Do not enter/apply correctors until all evaluations are complete and analyzed.

PATCH TEST RESULTS/CORRECTORS

Evaluators	Latency (sec)	Pitch (deg)	Roll (deg)	Yaw (deg)
Kay MacDonald	0.00	-0.90	-0.11	0.88
Daniel Smith	0.00	-1.09	-0.17	0.96
Tami Beduhn	0.00	-1.07	-0.12	0.96
Caryn Zacharias	0.00	-0.90	-0.18	0.75
Averages	0.00	-0.99	-0.15	0.89
Standard Deviation	0.00	0.10	0.04	0.10
FINAL VALUES	0.00	-0.99	-0.15	0.89

Final Values based on _____

Resulting HVF File Name FA_2805_400kHz_7125_512bms_2012.hvf

MRU Align StdDev gyro 0.10 Value from standard deviation of Heading offset values
 MRU Align StdDev Roll/Pitch 0.07 Value from averaged standard deviations of pitch and roll offset values

NARRATIVE

- HVF Hydrographic Vessel File created or updated with current offsets

Name: Tami Beduhn

Date: 4/15/2012

Side Scan Sonar Calibration

Field Unit: *Fairweather* (S220)

Date of Test: 3/8/2012 (Dn 068)

Calibrating Hydrographer(s): Beduhn, Smith, Loy, Cruz

SIDE SCAN SYSTEM INFORMATION

Side Scan System: Klein System Lightweight 5000

System Location: Launch 2805

TPU Serial Number: 176

Towfish Serial Number: 321

Cable Type: Stainless steel armored w/grease termination

Date of Most Recent EED / Factory Checkout: Unkown

VESSEL INFORMATION

Sonar Configuration: Towed

Cable Measurement System (if applicable): marked cable (5m increments)

Date of Current Vessel Offset Measurement / Verification: March 15, 2012

Date of Current Cable Measurement / Verification (if applicable): March 15th, 2012

TEST INFORMATION

Wind / Seas / Sky: Clear skys, light wind

Locality: Newport, OR

Sub-Locality: Yaquina River, near the turning basin

Description of Bathymetry: flat/gently sloping

Bottom Type: sandy/muddy

Approximate Water Depth: 8-10 m

Description of Target: bouy block

Approximate Target Size: (should be approximately 1m L x 1m W x 1m H)

TEST INFORMATION (continued)

Target Position: 44 37 34.01 N 124 02 16.56 W

Description of Positioning Method: MBES

Estimated Target Position Error: 5m

Approximate Survey Speed: 5-7 kts

Approximate Towfish Altitude: 4-7 m

DATA ACQUISITION INFORMATION					
Line Number	Heading	Speed	Fish Altitude	Range Scale	Target Seen?
112	122	4.55 kts		50 m	Y
105	298	6.3 kts		50 m	Y
111	121	4.4 kts		50 m	Y
106	125	4 kts		50 m	Y
111	292	7 kts		75 m	Y
105	127	5 kts		50 m	Y
112			7 m	75 m	Y
104		4.5 kts	5-6 m	50 m	Y
113				75 m	Y
106		4.5 kts		50 m	Y
104				75 m	Y
110		4.5 kts	6 m	50 m	Y
105		7 kts	6 m	75 m	Y
109				50 m	Y
103		7 kts		75 m	Y
113		6.9 kts		75 m	Y
111	121	6 kts		100 m	Y
105	123	5 kts		100 m	Y
112	290	7 kts	7 m	100 m	Y
106	126	5 kts		100 m	Y
113	298	7 kts		100 m	Y
104	126	5 kts		100 m	Y
106	296	7 kts		100 m	Y
111	120	5 kts	6 m	100 m	Y
105	296	7.5 kts	7 m	100 m	Y
112	120	5.5 kts	7 m	100 m	Y
104	293	8 kts	6 m	100 m	Y
110	120	5 kts	5 m	100 m	Y

Contact Northing	Contact Easting		Mean Easting	Mean Northing	
0.917	45.506		417602.7706	4941943.314	
1.501	45.276				
1.183	45.269		1.96Std Dev East'n	1.96Std Dev Nor'n	
0.246	45.181		4.02	2.67	
2.375	44.765				
2.181	44.468		Target Easting	Target Northing	
6.179	44.395		417601.621	4941943.169	
3.468	44.218				
0.958	43.772		The Target		
0.658	43.554				
5.397	43.494				
1.341	43.334				
0.99	43.139				
3.655	43.116				
1.599	43.031				
1.896	42.694				
3.23	42.166				
2.261	42.045				
0.965	42.082				
2.45	41.942				
5.162	41.863				
7.852	41.862				
6.067	41.852				
3.963	40.512				

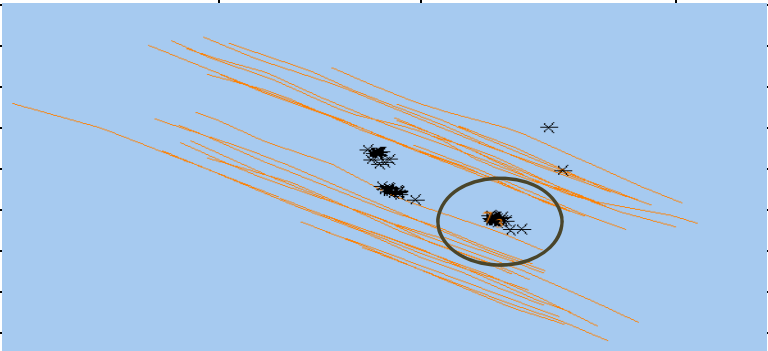
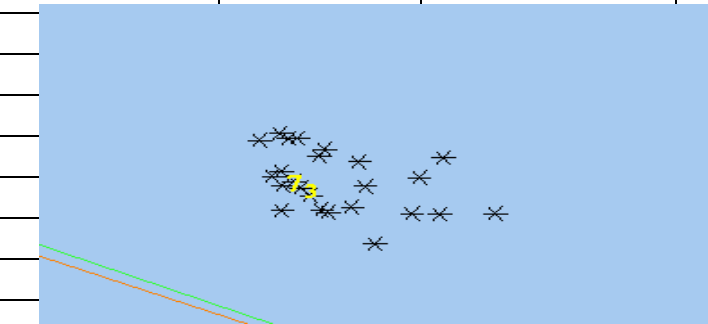

TEST RESULTS

Number of Passes on Target: 28
 Successful Target Detections: 24
 Mean Detected Position (Easting and Northing): 417602.77 4941943.31
 Distance from Mean Position to True Position (m): 1.16
 Approximate 95% Confidence Radius (m): 3.35

NARRATIVE

Three bouy blocks were located in the area of side scan testing. The easternmost one was used for patch testing, however all three showed up well in the majority of the side scan passes. Of the 28 passes, 24 had successful detection well within the allowable accuracy of 10 meters.

NOAA POS/MV Calibration Report

Fill out all fields! See previous years as an example.

Yellow areas require screen grabs!

Ship: FAIRWEATHER

Vessel: 2805

Date: 3/13/2012

Dn: 73

Personnel: SS Abraham, ENS Smith, ENS Younkin

PCS Serial #: 3628

IMU Serial #: 294

IP Address: 129.100.1.200

POS controller Version (Use Menu Help > About): 5.1.0.2

POS Version (Use Menu View > Statistics): _____

GPS Receivers

Primary Receiver Serial #: 31171727

Secondary Receiver Serial #: 31185275

2011_068_2805.000
 POSMV filename(s)

Calibration area

Location: Yaquina Bay

Approximate Position: _____

Lat	44	37	39.5
Lon	124	2	52.3

DGPS Beacon Station: FT Stevens

DGPS Receiver Serial#: _____

Frequency: 287Khz

Satellite Constellation

(Use View> GPS Data)

Primary GPS

Insert screen grabs

Secondary GPS

Note any differences from Primary GPS Receiver

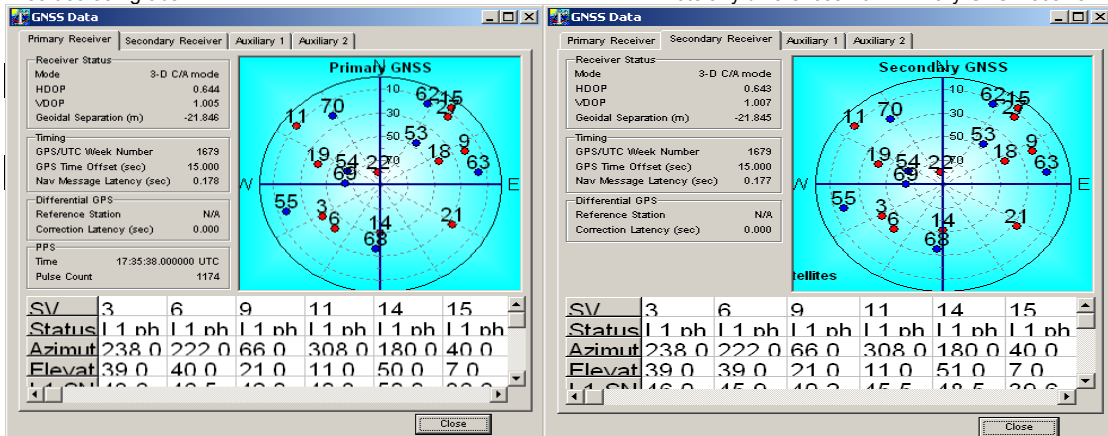

PDOP 2.17

(Use View> GAMS Solution)

POS/MV Configuration Settings

GAMS Parameter Setup

Two Antenna Separation (m)	1.443
Heading Calibration Threshold (deg)	0.500
Heading Correction (deg)	0.000

Baseline Vector

X Component (m)	0.000
Y Component (m)	0.000
Z Component (m)	0.000

Ok Close Apply View

POS/MV Calibration

Calibration Procedure:

(Refer to POS MV V4 Installation and Operation Guide, 4-25)

Start time: 1720

End time: 1801

Heading accuracy achieved for calibration: 0.049

Calibration Results:

GAMS Parameter Setup

Two Antenna Separation (m)	1.450
Heading Calibration Threshold (deg)	0.500
Heading Correction (deg)	0.000

Baseline Vector

X Component (m)	-0.018
Y Component (m)	1.449
Z Component (m)	-0.008

Ok Close Apply View

Save POS Settings on PC

(Use File > Store POS Settings on PC)

File Name: 2011_116_2806_GAMS

C:\HYPACK 2011\Projects\HSRR_2011\Raw\GNSS_Data\POSMV_Data

General Notes:

The POS/MV uses a Right-Hand Orthogonal Reference System

The right-hand orthogonal system defines the following:

- The x-axis is in the fore-aft direction in the appropriate reference frame.
- The y-axis is perpendicular to the x-axis and points towards the right (starboard) side in the appropriate reference frame.
- The z-axis points downwards in the appropriate reference frame.

The POS/MV uses a Tate-Bryant Rotation Sequence

Apply the rotation in the following order to bring the two frames of reference into complete alignment:

- a) Heading rotation - apply a right-hand screw rotation θ_z about the z-axis to align one frame with the other.
- b) Pitch rotation - apply a right-hand screw rotation θ_y about the once-rotated y-axis to align one frame with the other.
- c) Roll rotation - apply a right-hand screw rotation θ_x about the twice-rotated x-axis to align one frame with the other.

SETTINGS

Input/Output Ports (Use Settings > Input/Output Ports)

COM1

Input/Output Ports Set-up

COM1 | COM2 | COM3 | COM4 | COM5

Baud Rate: 9600

Parity: None Even Odd

Data Bits: 7 Bits 8 Bits

Stop Bits: 1 Bit 2 Bits

Flow Control: None Hardware XON/XOFF

Output Select: NMEA

NMEA Output:

- \$INGST
- \$INGGA
- \$INHDT
- \$INZDA
- \$INVTG
- \$PASHR

Update Rate: 5 Hz

Talker ID: IN

Input Select: None

Roll Positive Sense: Port Up Starboard Up

Pitch Positive Sense: Bow Up Stern Up

Heave Positive Sense: Heave Up Heave Down

Close Apply

COM2

Input/Output Ports Set-up

COM1 | COM2 | COM3 | COM4 | COM5

Baud Rate: 115200

Parity: None Even Odd

Data Bits: 7 Bits 8 Bits

Stop Bits: 1 Bit 2 Bits

Flow Control: None Hardware XON/XOFF

Output Select: Binary

Binary Output:

Update Rate: 50 Hz

Frame: Sensor 1 Sensor 2

Formula Select: SIMRAD 3000 (TSS)

Input Select: None

Roll Positive Sense: Port Up Starboard Up

Pitch Positive Sense: Bow Up Stern Up

Heave Positive Sense: Heave Up Heave Down

Close Apply

COM3

Input/Output Ports Set-up

COM1 | COM2 | **COM3** | COM4 | COM5

Baud Rate 4800	Parity <input checked="" type="radio"/> None <input type="radio"/> Even <input type="radio"/> Odd	Data Bits <input type="radio"/> 7 Bits <input checked="" type="radio"/> 8 Bits	Stop Bits <input checked="" type="radio"/> 1 Bit <input type="radio"/> 2 Bits	Flow Control <input checked="" type="radio"/> None <input type="radio"/> Hardware <input type="radio"/> XON/XOFF
-------------------	--	--	---	---

Output Select
None

Input Select
Base 1 GPS

Base GPS Input
Input Type: RTCM 1 or 9 Datum: WGS84

Line
 Serial Modem Modem Settings

Close Apply

SETTINGS Continued

Heave Filter

Heave Bandwidth (sec) 12.000

Damping Ratio 0.707

Ok Close Apply

Events (Use Settings > Events)

Events

Event 1
 Positive Edge Trigger
 Negative Edge Trigger

Event 2
 Positive Edge Trigger
 Negative Edge Trigger

Ok Close Apply

INSTALLATION (Use Settings > Installation)

Lever Arms & Mounting Angles

Lever Arms & Mounting Angles | Sensor Mounting | Tags, Multipath & AutoStart

Ref. to IMU Lever Arm X (m) 0.000 Y (m) 0.000 Z (m) 0.000	IMU Frame w.r.t. Ref. Frame X (deg) 0.000 Y (deg) 0.000 Z (deg) 0.000
Ref. to Primary GPS Lever Arm X (m) -0.806 Y (m) -0.682 Z (m) -3.174	Ref. to Vessel Lever Arm X (m) 0.000 Y (m) 0.000 Z (m) 0.000
Notes: 1. Ref. = Reference 2. w.r.t. = With Respect To 3. Reference Frame and Vessel Frame are co-aligned	Ref. to Centre of Rotation Lever Arm X (m) 0.000 Y (m) 0.000 Z (m) 0.000

Ok Close Apply View

In Navigation Mode , to change parameters go to Standby Mode !

Tags, Multipath and Auto Start

(Use Settings > Installation > Tags, Multipath and Auto Start)

The dialog box has three tabs: 'Lever Arms & Mounting Angles', 'Sensor Mounting', and 'Tags, Multipath & AutoStart'. The 'Tags, Multipath & AutoStart' tab is active. It contains three sections: 'Time Tag 1' with radio buttons for POS Time, GPS Time, and UTC Time (UTC Time is selected); 'Time Tag 2' with radio buttons for POS Time, GPS Time, UTC Time, and User Time (POS Time is selected); and 'AutoStart' with radio buttons for Disabled and Enabled (Enabled is selected). A 'Multipath' section has radio buttons for Low, Medium, and High (Low is selected). At the bottom are 'Ok', 'Close', 'Apply', and 'View' buttons, and a note: 'In Navigation Mode, to change parameters go to Standby Mode!'.

Sensor Mounting

(Use Settings > Installation > Sensor Mounting)

The dialog box has three tabs: 'Lever Arms & Mounting Angles', 'Sensor Mounting', and 'Tags, Multipath & AutoStart'. The 'Sensor Mounting' tab is active. It contains six sections for coordinate and angle inputs: 'Ref. to Aux. 1 GPS Lever Arm' (X, Y, Z in meters), 'Ref. to Aux. 2 GPS Lever Arm' (X, Y, Z in meters), 'Ref. to Sensor 1 Lever Arm' (X, Y, Z in meters), 'Sensor 1 Frame w.r.t. Ref. Frame' (X, Y, Z in degrees), 'Ref. to Sensor 2 Lever Arm' (X, Y, Z in meters), and 'Sensor 2 Frame w.r.t. Ref. Frame' (X, Y, Z in degrees). All input fields contain '0.000'. At the bottom are 'Ok', 'Close', 'Apply', and 'View' buttons, and a note: 'In Navigation Mode, to change parameters go to Standby Mode!'.

User Parameter Accuracy

(Use Settings > Installation > User Accuracy)

The dialog box has a title bar 'User Parameter Accuracy' and a close button. It contains four input fields under the heading 'RMS Accuracy': 'Attitude (deg)' with value 0.050, 'Heading (deg)' with value 0.050, 'Position (m)' with value 2.000, and 'Velocity (m/s)' with value 0.500. At the bottom are 'Ok', 'Close', and 'Apply' buttons.

Frame Control

(Use Tools > Config)

User Frame Primary GPS Measurement
 IMU Frame Auxiliary GPS Measurement
 Use GAMS enabled

GPS Receiver Configuration

(Use Settings> Installation> GPS Receiver Configuration)

Primary GPS Receiver

Secondary GPS Receiver

Post Processing of GAMS Calibration Processing Log

Date	Dn	Personnel
3/13/2012	073	ENS Smith
<input checked="" type="checkbox"/>	POS Pac Processing	Allow decimeter level freedom when processing
<input checked="" type="checkbox"/>		Reprocess using new values, but restrict to 10 cm of freedom
<input checked="" type="checkbox"/>		Reprocess using new values, again use 10 cm of freedom
<input checked="" type="checkbox"/>		Continue iterating until values no longer change
	Final Antenna Separation/ Lever Arms Determined	<input checked="" type="checkbox"/> See FOO/CST with values
	New Values entered in POS View?	<input type="checkbox"/> Values

GAMS Calibration Post-Processing Results

Date: 3/13/2012 Dn: 73
Vessel: 2805
POS File Name: GAMMS_073_CONCAT.000
POSPac Project Name: 2012_073_2805_GAMS.000
Project Location: T:\Testing_2012\Caris\GNSS_DATA

Lever Arm Offsets

(Project Settings > GNSS-Inertial Processor > Lever Arms and Mounting Angles)

	X	Y	Z
Reference to IMU Lever Arm	-0.008	-0.031	0.130

	X	Y	Z
Starting Value (Reference to Primary GNSS Lever Arm)	-0.77	-0.75	-3.15

POSPac Display Calibrated Installation Parameters

	X	Y	Z
Run 1	-0.783	-0.745	-3.159
Run 2	-0.783	-0.745	-3.159
Run 3			

GAMS Calibration Results

Two Antenna Separation (m) 1.454

ERDDM Acquisition Log

Launch 2805 400kHz

Vessel

3/13/2012		Yaquina Bay	15-20Kt
Date	Dn	Local Area	Wx

SS Abraham, ENS Smith, ENS Younkin
Personnel

Comments

Slack Observed at approximately 1900 | Fort Stevens, WA - 287 kHz (100 BPS)
Tidal Cycle Notes | USCG DGPS Beacon Used

2011_073_2805.100 - 111
POSMV filename(s)

POS File	Azimuth	Vessel Speed	RPM	Start and End Time
2011_068_2805.100	5 Minute Break			
2011_068_2805.101, 102	125	04	670	1812 start, 1817 end
2011_068_2805.102, 103	125	06	1020	1817 start, 1822 end
2011_068_2805.103, 104	306	06	800	1822 start, 1827 end
2011_068_2805.104, 105	306	4.3 (at idle)	600	1827 start, 1832 end
2011_068_2805.105, 106	5 Minute Break			
2011_068_2805.106, 107	125	08	1440	1838 start, 1843 end
2011_068_2805.107	306	08	1230	1843 start, 1848 end
2011_068_2805.107, 108	5 Minute Break			
2011_068_2805.108, 109	125	010	1730	1853 start, 1858 end
2011_068_2805.109, 110	306	010	1710	1858 start, 1903 end
2011_068_2805.110, 111	5 Minute Break			1908 end

Processing Log

3/13/2012	073	SS Abraham, ENS Smith, ENS Younkin
Date	Dn	Personnel

- POS Files Processed in POS Pac | Singlebase - P367 (Newport Airport)
Smartbase or Singlebase? Station used.
- SBET Processed in Pydro Using the ERDDM Tool
- Graph and Table Values compared with previous year
- Documentaion Complete in DAPR Appendix
- See OPS/CST for updating HVF with new values

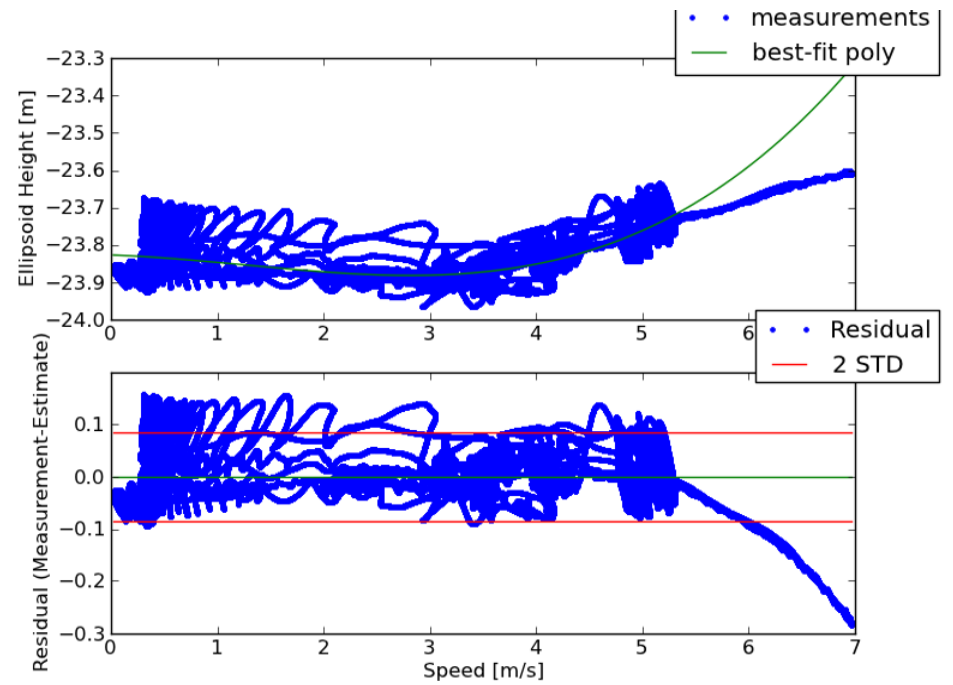
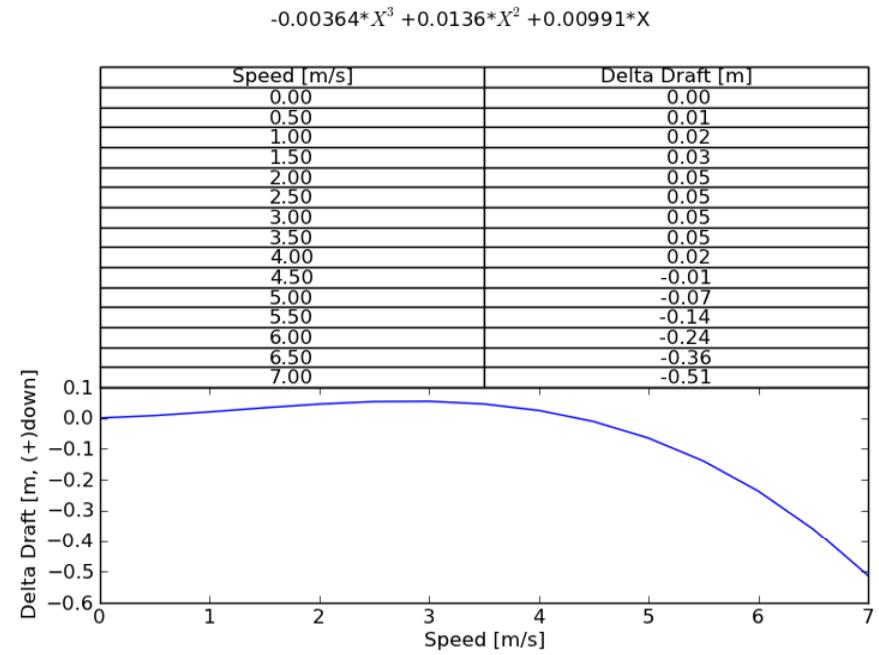
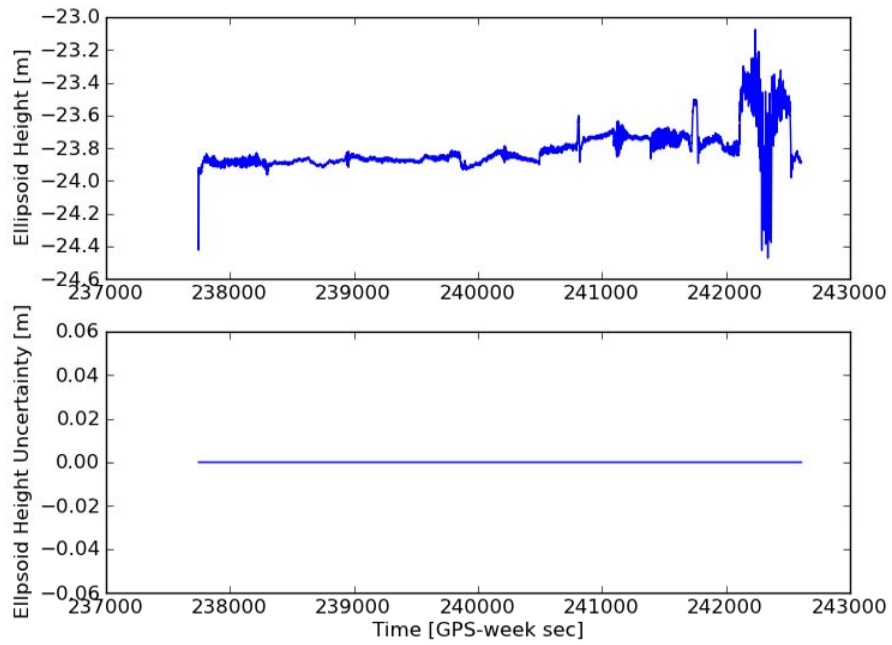

2808 Offsets and Measurements - Summary

Measurement aka	IMU to RP*	IMU to 7125 (Receiver) <i>SWATH1 x,y,z & MRU to Trans</i>	Port Ant to 7125 <i>Nav to Trans x,y,z</i>	RP* to Waterline	Port Ant to Stbd Ant	IMU to Port Ant	IMU to Heave
Coord. Sys.	Caris	Caris	Caris	Caris	Scaler Distance	Caris Pos/Mv	Caris Pos/Mv
x	0.000	0.004	0.685	n/a	1.453	-0.682	0.000
y	0.000	0.250	1.086	n/a		-0.837	0.000
z	0.000	0.477	3.637	-0.093		-3.160	0.000

*IMU is Reference Point

-0.123 (2010 used for K5K)

Vessel Offsets for 2808 7125 are derived from the NGS Survey, January 2010, Trimble Equipment Specs, and 2011 and 2010 Measured Values.

Calculations

Coord. Sys./ Source	IMU to 7125	Port Ant to 7125	RP to Waterline	Port Ant to Stbd Ant	IMU to Port Ant	IMU to Heave
NGS	IMU (m) x 0.00000 y 0.00000 z 0.00000	IMU to x -0.68151 Port Ant (m) y -0.83666 (calculated) z 3.15974	RP to Waterline (m) (waterline z 0.093 worksheet)	IMU to x -0.68151 Port Ant (m) y -0.83666 (calculated) z 3.15974	IMU (m) x 0.00000 y 0.00000 z 0.00000	IMU (m) x 0.00000 y 0.00000 z 0.00000
MBES RP Rcvr - Phase Center (m)	x 0.00351 y 0.24969 z -0.47677	IMU to x 0.00351 Phase Ctr y 0.24969 (calculated) z -0.47677	2010 RP to Waterline (m) (waterline z 0.123 worksheet)	IMU (m) x, y, z 0.00000 Top of Stbd Ant (m) x 0.77098 y -0.83402 z 3.13235	Top of Port Ant (m) x -0.68151 y -0.83666 z 3.14844 Base to top of Port Ant (measured) (m) z 0.073 Base to top of Stbd Ant (measured) (m) z 0.073 Bottom of Stbd Ant (calculated) (m) z 3.05935 Base to Phase Cntr of Stbd Ant (eqp spc) (m) z 0.0843	Heave Pt (m) x 0.00000 (by design) y 0.00000 z 0.00000
Coord. Sys. NGS	IMU to x 0.00351 Phase Ctr y 0.24969 z -0.47677	Port Ant to 7125 x 0.68502 y 1.08635 z -3.63651	RP to Waterline x n/a y n/a z 0.093	Port Ant to Stbd Ant Scalar Distance 1.4526	IMU to Port Ant x -0.68151 y -0.83666 z 3.15974	IMU to Heave x 0.00000 y 0.00000 z 0.00000
Coord. Sys. CARIS	x 0.00351 y 0.24969 z 0.47677	Coord. Sys. CARIS x 0.68502 y 1.08635 z 3.63651	Coord. Sys. CARIS x n/a y n/a z -0.093		Coord. Sys. Pos/Mv x -0.83666 y -0.68151 z -3.15974	Coord. Sys. Pos/Mv x 0.00000 y 0.00000 z 0.00000

Description of Offsets for Launch 2808

All Values Shown are in CARIS Coordinates

The Ship Reference Frame (SRF) for Launch 2808 was based from the IMU reference point as the 0,0,0 point. Physical locations were measured with x,y,z offsets from this point. These locations were used to calculate offsets of items with respect to each other, as described for each offset.

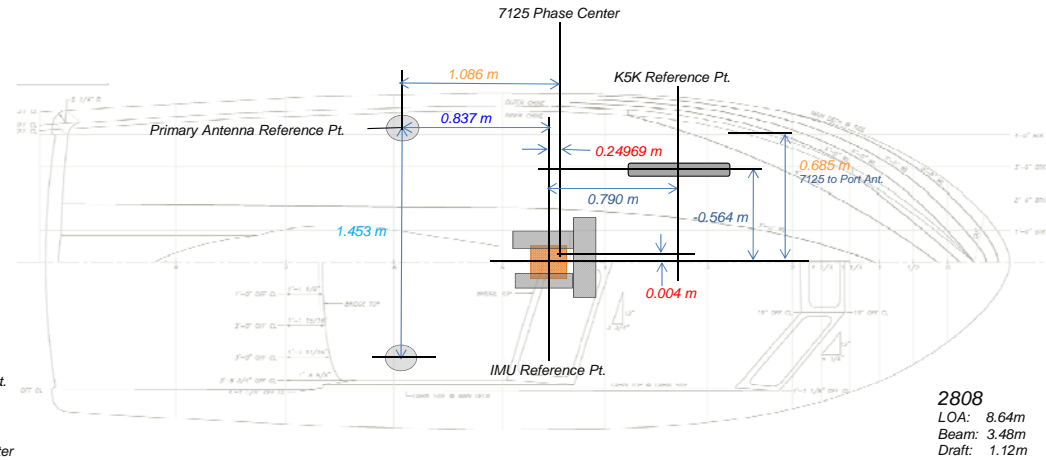
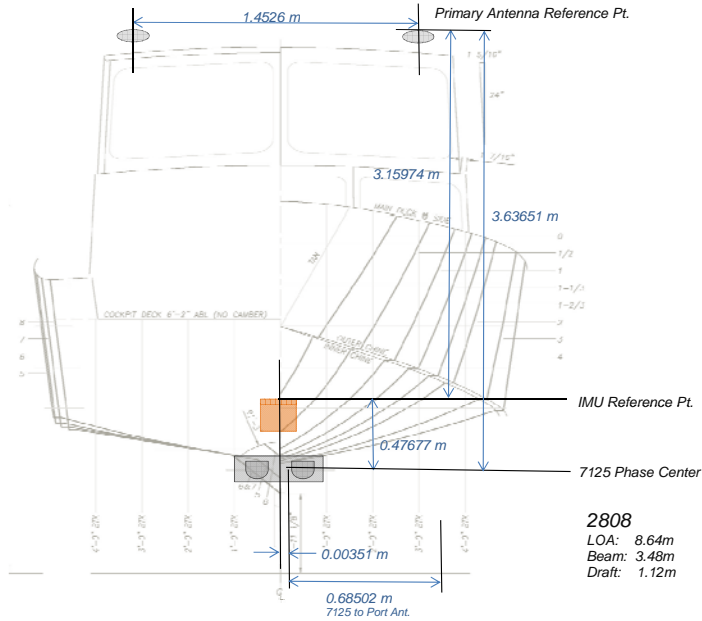

2808
LOA: 8.64m
Beam: 3.48m
Draft: 1.12m

IMU to 7125		
x	y	z
0.004	0.250	0.477

The physical positions of the IMU and the receiver phase center of the 7125 were measured during the NGS survey. These physical measurements were taken while the launch was secured on the pier and thought to be as level as possible. The measured values for the IMU and MB were taken directly for the report. The difference is the offset from the IMU to the phase center of the 7125 which was then transposed from the NGS to the CARIS coordinate system.

Port Ant to 7125		
x	y	z
0.685	1.086	3.637

The values were calculated by subtracting the physical height of the of the Port Antenna to the IMU x, y, z values from the respective values of the IMU to the 7125. The calculated values were then transposed from the NGS to the CARIS coordinate system.

RP to Waterline		
x	y	z
n/a	n/a	-0.093

The average vertical distance from Port Benchmark to waterline and the Starboard Benchmark to the waterline were measured by FAIRWEATHER personnel using a steel tape and bubble level. These values were combined with the Z value of the Benchmarks to the RP/IMU to get an average for the waterline to RP. The Waterline Measurement value is in NGS coordinates initially and is converted to CARIS coordinates.

Port Ant to Stbd Ant
Scalar Distance
1.453

The location of the phase center of the port and starboard POS/MV antennas were surveyed by NGS. The z-values were adjusted to the phase center. Then the scalar distance between the phase centers was calculated.

IMU to Port Antenna		
x	y	z
-0.682	-0.837	-3.160

The location of the IMU and the location of the top of port antenna were surveyed by NGS. The z-value of the antenna was calculated by subtracting the height of the antenna and then adding the value from the base of the antenna to the phase center of the antenna. The calculation results were then transposed from the NGS to the CARIS coordinate system.

IMU to Heave		
x	y	z
0.000	0.000	0.000

The Heave Point is assumed to coincide with the IMU location.

IMU to K5K		
x	y	z
-0.564	0.790	0.777

The location of the IMU and the location of the forward keel benchmark were surveyed by NGS. BM to K5K were measured by FAIRWEATHER personnel using a steel tape and bubble level.

Waterline Measurements

Measuring Party: Francksen, Stuart, Pfundt, Smith

2808

Waterline measurements should be negative and cm!

	2808	
	Port Benchmark to Waterline	Stbd Benchmark to Waterline
Measure 1	-94.3	-98.3
Measure 2	-95.8	-97.1
Measure 3	-96.5	-98.4
Avg (cm)	-95.53	-97.93
Avg (m)	-0.9553	-0.9793
Stdev	0.01124	0.00723
BM Z-value (m)*	1.07600	1.04444
BM to WL (m)	0.121	0.065
Individual measurement	0.13300	0.06144
	0.11800	0.07344
StDev for TPU xls (of 6 #s)	0.032	0.06044

Measuring Party: Francksen, Pfundt, Abraham

2808

Waterline measurements should be negative and cm!

	2808	
	Port Benchmark to Waterline	Stbd Benchmark to Waterline
Measure 1	-96.2	-97.1
Measure 2	-92.1	-96.1
Measure 3	-94.0	-96.8
Avg (cm)	-94.10	-96.67
Avg (m)	-0.9410	-0.9667
Stdev	0.02052	0.00513
BM Z-value (m)	1.07600	1.04444
BM to WL (m)	0.135	0.078
Individual measurement	0.11400	0.07344
	0.15500	0.08344
StDev for TPU xls (of 6 #s)	0.034079	0.07644

Fill in Yellow squares only!

Date: 3/14/2011
 Fuel Level: 62.6 GAL (about 1/2 full)
 Draft Tube:

Port-to-Stbd Z-difference

Theoretical	Actual	Error
0.0316	-0.0240	-0.0556

RP to WL Average (m)

0.093 NGS Coordinate System (do not enter into CARIS directly)
 (Add this value to VSSL_Offsets & Measurements_20XX.xls)

utilized in Offsets and Measurements and TPU spreadsheet

Date: 3/21/2011
 Fuel Level: 100gal
 Draft Tube:

Port-to-Stbd Z-difference

Theoretical	Actual	Error
0.0316	-0.0257	-0.0572

RP to WL Average (m)

0.106 NGS Coordinate System (do not enter into CARIS directly)
 (or add this value to VSSL_Offsets & Measurements_20XX)

US DEPARTMENT OF COMMERCE
NATIONAL OCEANIC & ATMOSPHERIC ADMINISTRATION
NATIONAL OCEAN SERVICE
NATIONAL GEODETIC SURVEY
GEODETIC SERVICES DIVISION
INSTRUMENTATION & METHODOLOGIES BRANCH

**NOAA SURVEY VESSEL 2808
POS MV COMPONENTS SPATIAL RELATIONSHIP
SURVEY
FIELD REPORT**

Kendall L. Fancher
January, 2010



**NOAA SURVEY VESSEL 2808
POS MV COMPONENTS SPATIAL RELATIONSHIP SURVEY**

PURPOSE

The primary purpose of the survey was to precisely determine the spatial relationship between various hydrographic surveying sensors, launch bench marks and the components of a POS MV navigation system aboard the NOAA survey vessel 2808.

PROJECT DETAILS

This survey was conducted in Seattle, WA at the NOAA Western Center on the 27th of January, 2010. The weather was foggy then sunny with temperatures in the 40s to 50s. For this survey, the vessel was on blocks, supported by boat jacks. The vessel was reported to have been leveled relative to the IMU.

INSTRUMENTATION

A Leica TDA5005 precision total station was used to make all measurements.

Technical Data:

Standard Deviation	
Horizontal angle	0.5 seconds
Vertical angle	0.5 seconds
Distance measurement	1mm + 1ppm

Leica precision prisms were used as sighting targets. Prisms were configured to have a zero mm offset.

PERSONNEL

Kendall Fancher NOAA/NOS/NGS/GSD/I&M BRANCH
(540) 373-1243
kendall.fancher@noaa.gov

Dennis Lokken NOAA/NOS/NGS/GSD/I&M BRANCH
(540) 373-1243
dennis.lokken@noaa.gov

**NOAA SURVEY VESSEL 2808
POS MV COMPONENTS SPATIAL RELATIONSHIP SURVEY**

DEFINITION OF THE REFERENCE FRAME

For this survey, data was collected in a 3-D right handed Cartesian coordinate system. The origin of this coordinate system is defined as the center of the IMU target. The Y (Northing) axis is parallel to the centerline of the launch and is positive towards the bow of the launch. The X (Easting) axis is perpendicular to the Y axis and is positive towards the starboard side of the launch. The Z (Elevation) axis is perpendicular to the XY plane and is positive towards the top of the launch. The coordinates of the points established this survey are reported in this coordinate system and are provided in Appendix A.

SURVEY METHODOLOGY

Four temporary control points, (1, 2, 3, and 4), were established around the vessel such that every point to be positioned on the launch could be observed from at least two separate locations.

Coordinates of 100.000N, 100.000E, and 100.000U were assumed for temporary control point 1. A distance and height difference were measured between control points 1 and 2. Temporary control point 2 was assumed to have an Easting of 100.000. The measured distance between these two points was used to determine the Northing for temporary control point 2. The height difference between the two points was used to determine the Up component for control point 2.

Control point 1 was occupied and control point 2 was observed to initialize the instrument. After initialization, control point 4 and all visible points to be observed on the launch were observed in both direct and reverse. The stability of the instrument setup was checked at conclusion of the data set collection by checking back to temporary control point 2.

Control point 2 was occupied and control point 1 was observed to initialize the instrument. After initialization, control point 3 and all visible points to be observed on the launch were observed in both direct and reverse. The stability of the instrument setup was checked at conclusion of the data set collection by checking back to temporary control point 1.

Control point 3 was occupied and control point 2 was observed to initialize the instrument. After initialization, control point 4 and all visible points to be observed on the launch were observed in both direct and reverse. The stability of the instrument setup was checked at conclusion of the data set collection by checking back to temporary control point 2.

NOAA SURVEY VESSEL 2808 POS MV COMPONENTS SPATIAL RELATIONSHIP SURVEY

Control point 4 was occupied and control point 3 was observed to initialize the instrument. After initialization, all visible points to be observed on the launch were observed in both direct and reverse. Control point 1 was also observed in order to evaluate the accuracy of the traverse. Inverse computations between the original and observed control point yielded a horizontal accuracy, or traverse closure of 0.001m and a vertical accuracy of 0.000m. The stability of the instrument setup was checked at conclusion of the data set collection by checking back to temporary control point 2.

Inverses were computed between the two positions determined for all points surveyed to evaluate their accuracy relative to the temporary control network. Inverse reports are included in appendix B.

The reference frame was rotated using CENTERLINE STERN BM (CLS) as the point of rotation. A zero degree azimuth was used during the rotation from CLS to CENTERLINE BOW BM (BMB). The reference frame was then translated to relocate the origin of the reference frame to the IMU. The resulting coordinates are reported in appendix A.

DISCUSSION

The positions given for the POS GPS antennas (Zephyr Model II p/n 57970-00) are to the top center of the antenna. To correct the Z value provided in this report for each antenna to the electronic phase center, I recommend the following steps be taken;

- 1) Determine the physical height of the GPS antenna. This information is probably located on the antenna or with equipment documentation.
- 2) Investigate to find the electronic phase center offset of the antenna. This information is probably located on the antenna or with equipment documentation. This value may also be available at the NGS website for antenna modeling.
- 3) Subtract the total height of the antenna from the Z value for each antenna. This will give you a Z value for the antenna ARP (antenna reference point)
- 4) Then add to this value the electronic phase center offset value appropriate for the antenna model.



NOAA SURVEY VESSEL 2808 POS MV COMPONENTS SPATIAL RELATIONSHIP SURVEY

Two reference points (MBF and MBA) were positioned in order to facilitate future measurements to the Multi-Beam sensor by launch personnel. These reference points are punch marks set along the center of the keel, at the locations described in the image at right.



A point on the Multi-Beam transducer (MB) was measured directly this survey. The measured point was at the center of the bottom of the transducer. No mark was left to indicate the measured point.

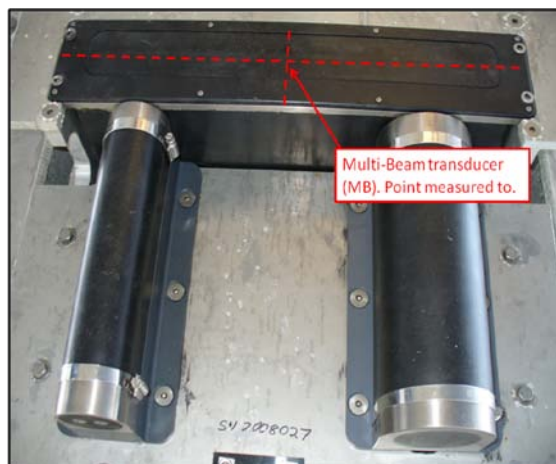

The point positioned for the Inertial Motion Unit (IMU) this survey was the center of the target affixed to the top of the unit. Additionally, a reference mark (IMUR) was established on the plate the IMU is attached to at a point where two scribed lines intersect, forward of the IMU.

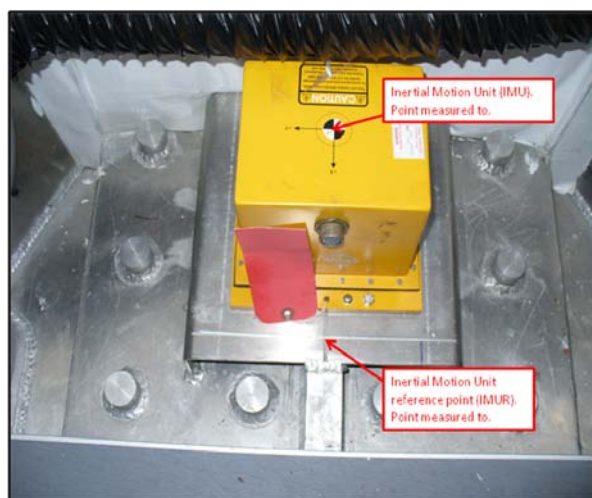

NOAA SURVEY VESSEL 2808
POS MV COMPONENTS SPATIAL RELATIONSHIP SURVEY

STATION LISTING

BMB-	CENTERLINE BOW BM The center of a cross mark inscribed into the top of a square metal flange, welded to the deck, along the centerline and near the bow of the launch.
CLS-	CENTERLINE STERN BM The center of a cross mark inscribed into the top of a square metal flange, welded to the deck, along the centerline and near the stern of the launch.
BMP-	PORT SIDE BM The center of a cross mark inscribed into the top of a square metal flange, welded to the top of the deck, near the middle of and along the port side of the launch.
BMS-	STARBOARD SIDE BM The center of a cross mark inscribed into the top of a square metal flange, welded to the top of the deck, near the middle of and along the starboard side of the launch.
MBF-	KEEL BM A punch mark set along the bottom center of the keel, fore of the multi-beam transducer, 0.030 m from a point where the keel makes a 90 degree angle upwards.
MBA-	KEEL BM A punch mark set along the bottom center of the keel, aft of the multi-beam transducer, 0.030 m from a point where the keel makes a 90 degree angle upwards.
IMU-	IMU TARGET Center of a target affixed to the top of the IMU housing.
IMUR-	IMU REFERENCE BM The intersection of two scribed lines atop a metal support plate for the IMU and forward of the IMU.
GPSP-	PORT SIDE GPS ANTENNA REFERENCE POINT The top center of the port side GPS antenna for the POS system.
GPSS-	STARBOARD GPS ANTENNA REFERENCE POINT The top center of the starboard side GPS antenna for the POS system.
MB-	MULTI-BEAM REFERENCE POINT The physical bottom center of the Multi-Beam transducer.

Appendix A

Coordinate Report Launch 2808

<i>Pt Name</i>	<i>North(Y)</i>	<i>East(X)</i>	<i>UP(Z)</i>	<i>ID</i>
IMU Target	0.00000	0.00000	0.00000	IMU
IMU Reference BM	0.13282	-0.00186	-0.16518	IMUR
Centerline Stern BM	-4.07730	0.01391	0.61506	CLS
Centerline Bow BM	3.44544	0.01391	1.44047	BMB
Portside GPS Ant. Ref. Point	-0.83666	-0.68151	3.14844	GPSP
Starboard GPS Ant. Ref. Point	-0.83402	0.77098	3.13235	GPSS
Multi-Beam Ref.Point	0.24969	0.00351	-0.47677	MB
Keel BM	0.44021	-0.00126	-0.60545	MBF
Keel BM	-0.22600	0.00192	-0.53583	MBA
Port Side BM	0.08204	-1.42963	1.07600	BMP
Starboard Side BM	0.08324	1.46250	1.04444	BMS

Units = meters

Appendix B

Point to Point Inverse Launch 2808

<i>Pt. 1</i>	<i>Pt. 2</i>	<i>Dist.</i>	<i>Northing</i>	<i>Easting</i>	<i>Elevation</i>	<i>ID</i>
3	40	0.001	-0.001	0.000	0.00026	MBF
5	42	0.003	-0.002	-0.001	0.00013	MBA
4	41	0.002	-0.001	-0.002	0.00062	MB
14	55	0.006	-0.005	0.004	0.00049	IMUR
13	56	0.006	-0.004	0.004	0.00055	IMU
43	6	0.001	0.000	0.001	0.00048	CLS
33	44	0.000	0.000	0.000	0.00006	BMS
8	22	0.001	-0.001	0.000	0.00039	BMP
17	25	0.005	0.000	0.005	0.00011	BMB
24	34	0.001	0.000	0.000	0.00049	GPSS
23	7	0.000	0.000	0.000	0.00022	GPSP

Units = meters

FAIRWEATHER

Multibeam Echosounder Calibration

Launch 2808 200kHz

Vessel

4/14/2012	105	Shilshole
Date	Dn	Local Area

Smith, Marcus, Bowker
Calibrating Hydrographer(s)

Reson 7125	Hull Mounted	2009
MBES System	MBES System Location	Date of most recent EED/Factory Check

1812023	
Sonar Serial Number	Processing Unit Serial Number

Fixed Hull Mount	1/26/2010
Sonar Mounting Configuration	Date of current offset measurement/verification

Applanix POS/MV S/N:2560 IMU S/N:991	3/28/2012
Description of Positioning System	Date of most recent positioning system calibration

Acquisition Log

4/14/2012	105	Shilshole	sunny, 3 kt wind, light chop
Date	Dn	Local Area	Wx

Bottom Type	Approximate Water Depth
-------------	-------------------------

Marcum, Smith, Marcus, Bowker
Personnel on board

8 kt lines have noisy data
Comments

2012_121_2808.238-256
POSMV Filename(s)

2012_121_160540.he	1605	47/40/25.89N	122/25/29.63W	30	
SV Cast #1 filename	UTC Time	Lat	Lon	Depth	Ext. Depth

2012_121_172655.he	1726	47/40/25.89N	122/25/29.63W	32	
SV Cast #2 filename	UTC Time	Lat	Lon	Depth	Ext. Depth

SV Cast #3 filename	UTC Time	Lat	Lon	Depth	Ext. Depth

view parallel to track, one line with induced roll (outerbeam) or same lines bounded slope (nadir)
[same direction, different speed]

NAV TIME LATENCY

SV Cast #	XTF Line Filename	Heading	Speed (kts)	Remarks
	2012M_1051713	122	4.0	line 11
	2012M_1051716	138	8.0	line 11, Noisy Data
	2012M_1051715	317	4.0	Line 11
	2012M_1051718	314	8.0	line 11
	2012M_1051729	130	8.0	Line 11
	2012M_1051730	316	8.0	Line 11

PITCH

view parallel to track, same line (at nadir) [opposite direction, same speed]

SV Cast #	XTF Line Filename	Heading	Speed (kts)	Remarks
	2012M_1051713	122	4.0	Line 11
	2012M_1051715	317	4.0	Line 11
	2012M_1051719	130	4.0	Line 11
	2012M_1051721	310	4.0	Line 11

HEADING/YAW

view parallel to track, offset lines (outerbeams) [opposite direction, same speed]

SV Cast #	XTF Line Filename	Heading	Speed (kts)	Remarks
	2012M_1051723	126	4.0	Line 12
	2012M_1051724	322	4.0	Line 13
	2012M_1051726	115	4.0	Line 1
	2012M_1051728	306	4.0	Line 2

ROLL

view across track, same line [opposite direction, same speed]

SV Cast #	XTF Line Filename	Heading	Speed (kts)	Remarks
	2012M_1051734	234	4.0	Line 3
	2012M_1051737	060	4.0	Line 3
	2012X_1051925	239	4.0	Line 3, purposely waked by 2805
	2012X_1051928	058	4.0	Line 3, purposely waked by 2805

Processing Log

4/14/2012 | 105 | Faulkes

Date Dn Personnel

- Data converted --> HDCS_Data in CARIS
 - TrueHeave applied 2012_105_2808_Concat.000.fixed
 - SVP applied nearest in distance
 - Tide applied
- Zone file _____
- Lines merged
- Data cleaned to remove gross fliers

Compute correctors in this order

1. Precise Timing 2. Pitch bias 3. Heading bias 4. Roll bias

Do not enter/apply correctors until all evaluations are complete and analyzed.

PATCH TEST RESULTS/CORRECTORS

Evaluators	Latency (sec)	Pitch (deg)	Roll (deg)	Yaw (deg)
Faulkes	0.00	-1.45	0.19	0.68
Zacharias	0.00	-1.65	0.18	0.58
Beduhn	0.00	-1.47	0.12	0.49
Loy	0.00	-1.50	0.17	
MacDonald	0.00	-1.60	0.13	
Averages	0.00	-1.53	0.16	0.58
Standard Deviation	0.00	0.09	0.03	0.10
FINAL VALUES	0.00	-1.53	0.16	0.58

Final Values based on _____

Resulting HVF File Name _____

MRU Align StdDev gyro 0.10 Value from standard deviation of Heading offset values
 MRU Align StdDev Roll/Pitch 0.06 Value from averaged standard deviations of pitch and roll offset values

NARRATIVE

- HVF Hydrographic Vessel File created or updated with current offsets

Name: Tami Beduhn _____

Date: 4/15/2012 _____

FAIRWEATHER

Multibeam Echosounder Calibration

Launch 2808 400kHz

Vessel

4/30/2012	121	Shilshole
Date	Dn	Local Area

SST Franksen, AST Marcus, PS Raymond, SS Brooks

Calibrating Hydrographer(s)

Reson 7125	Hull Mounted	2009
MBES System	MBES System Location	Date of most recent EED/Factory Check

1812023	
Sonar Serial Number	Processing Unit Serial Number

Fixed Hull Mount	1/26/2010
Sonar Mounting Configuration	Date of current offset measurement/verification

Applanix POS/MV S/N:2560 IMU S/N:991	3/28/2012
Description of Positioning System	Date of most recent positioning system calibration

Acquisition Log

4/30/2012	121	Shilshole	OVC, seas 2-3ft, wind 10-15
Date	Dn	Local Area	Wx

Bottom Type	Approximate Water Depth
-------------	-------------------------

SS Brooks, SST Franksen, AST Marcus, PS Raymond

Personnel on board

Comments

2012_121_2808.238-256

POSMV Filename(s)

2012_121_160540.he	1605	47/40/25.89N	122/25/29.63W	30	
SV Cast #1 filename	UTC Time	Lat	Lon	Depth	Ext. Depth

2012_121_172655.he	1726	47/40/25.89N	122/25/29.63W	32	
SV Cast #2 filename	UTC Time	Lat	Lon	Depth	Ext. Depth

SV Cast #3 filename	UTC Time	Lat	Lon	Depth	Ext. Depth
---------------------	----------	-----	-----	-------	------------

view parallel to track, one line with induced roll (outerbeam) or same lines bounded slope (nadir)
[same direction, different speed]

NAV TIME LATENCY

SV Cast #	XTF Line Filename	Heading	Speed (kts)	Remarks
	2012M_1211632.Hsx	132°	4.0	swervy, low quality
	2012M_1211635	312°	4.0	
	2012M_1211637	132	4.0	
	2012M_1121639	312	8.0	
	2012M_1211641	132°	8.0	
	2012M_1211642	312	8.0	

PITCH view parallel to track, same line (at nadir) [opposite direction, same speed]

SV Cast #	XTF Line Filename	Heading	Speed (kts)	Remarks
	2012M_1211647	132	4.0	
	2012M_1211649	312	4.0	
	2012M_1211652	61°	4.0	
	2012M_1211655	241°	4.0	

HEADING/YAW view parallel to track, offset lines (outerbeams) [opposite direction, same speed]

SV Cast #	XTF Line Filename	Heading	Speed (kts)	Remarks
	2012M_1211702	132	4.0	roll warning on line
	2012M_1211705	310	4.0	
	2012M_1211709	138	4.0	half line due to set
	2012M_1211710	310	4.0	
	2012M_1211712	138	4.0	
	2012M_1211715	305	4.0	broke line due to set and buoy
	2012M_1211717	138	4.0	half line due to set

ROLL view across track, same line [opposite direction, same speed]

SV Cast #	XTF Line Filename	Heading	Speed (kts)	Remarks
	2021M_1211720	300	4.0	
	2012M_1211722	145	4.0	
	2012M_1211724	310	4.0	

Processing Log

4/30/2012 | 121 | Faulkes

Date Dn Personnel

- Data converted --> HDCS_Data in CARIS
 - TrueHeave applied 2012_121_2808_Concat
 - SVP applied HSRR 2808_121 Nearest in distance in 3 hours
 - Tide applied zero tide
- Zone file _____
- Lines merged
- Data cleaned to remove gross fliers

Compute correctors in this order

1. Precise Timing 2. Pitch bias 3. Heading bias 4. Roll bias

Do not enter/apply correctors until all evaluations are complete and analyzed.

PATCH TEST RESULTS/CORRECTORS

Evaluators	Latency (sec)	Pitch (deg)	Roll (deg)	Yaw (deg)
Faulkes	0.00	-1.20	0.26	0.39
Raymond	0.00	-1.17	0.29	
Zacharias	0.00	-1.10	0.27	
Beduhn	0.00	-1.12	0.25	0.42
Averages	0.00	-1.15	0.27	0.41
Standard Deviation	0.00	0.05	0.02	0.02
FINAL VALUES	0.00	-1.15	0.27	0.41

Final Values based on _____

Resulting HVF File Name _____

MRU Align StdDev gyro 0.02 Value from standard deviation of Heading offset values
 MRU Align StdDev Roll/Pitch 0.03 Value from averaged standard deviations of pitch and roll offset values

NARRATIVE

- HVF Hydrographic Vessel File created or updated with current offsets

Name: Tami Beduhn _____

Date: 4/15/2012 _____

POS/MV Configuration Settings

GAMS Parameter Setup

Two Antenna Separation (m) 1.453

Heading Calibration Threshold (deg) 0.500

Heading Correction (deg) 0.000

Baseline Vector

X Component (m) 0.000

Y Component (m) 0.000

Z Component (m) 0.000

Ok Close Apply View

Calibration Procedure:

(Refer to POS MV V4 Installation and Operation Guide, 4-25)

Start time: 1957

End time: 2026

Heading accuracy achieved for calibration: 0.049

Calibration Results:

GAMS Parameter Setup

Two Antenna Separation (m) 1.453

Heading Calibration Threshold (deg) 0.500

Heading Correction (deg) 0.000

Baseline Vector

X Component (m) 0.002

Y Component (m) 1.452

Z Component (m) -0.340

Ok Close Apply View

Save POS Settings on PC

(Use File > Store POS Settings on PC)

File Name: _____

C:\HYPACK 2011\Projects\HSRR_2011\Raw\GNSS_Data\POS MV_Data

General Notes:

The POS/MV uses a Right-Hand Orthogonal Reference System

The right-hand orthogonal system defines the following:

- The x-axis is in the fore-aft direction in the appropriate reference frame.
- The y-axis is perpendicular to the x-axis and points towards the right (starboard) side in the appropriate reference frame.
- The z-axis points downwards in the appropriate reference frame.

The POS/MV uses a Tate-Bryant Rotation Sequence

Apply the rotation in the following order to bring the two frames of reference into complete alignment:

- a) Heading rotation - apply a right-hand screw rotation θ_z about the z-axis to align one frame with the other.
- b) Pitch rotation - apply a right-hand screw rotation θ_y about the once-rotated y-axis to align one frame with the other.
- c) Roll rotation - apply a right-hand screw rotation θ_x about the twice-rotated x-axis to align one frame with the other.

SETTINGS

Input/Output Ports (Use Settings > Input/Output Ports)

COM1

Input/Output Ports Set-up

COM1 | COM2 | COM3 | COM4 | COM5

Baud Rate: 9600

Parity: None Even Odd

Data Bits: 7 Bits 8 Bits

Stop Bits: 1 Bit 2 Bits

Flow Control: None Hardware XON/XOFF

Output Select: NMEA

NMEA Output:

- \$INGST
- \$INGGA
- \$INHDT
- \$INZDA
- \$INVTG
- \$PASHR

Update Rate: 1 Hz

Talker ID: IN

Roll Positive Sense: Port Up Starboard Up

Pitch Positive Sense: Bow Up Stern Up

Heave Positive Sense: Heave Up Heave Down

Input Select: None

Close Apply

COM2

Input/Output Ports Set-up

COM1 | COM2 | COM3 | COM4 | COM5

Baud Rate: 115200

Parity: None Even Odd

Data Bits: 7 Bits 8 Bits

Stop Bits: 1 Bit 2 Bits

Flow Control: None Hardware XON/XOFF

Output Select: Binary

Binary Output:

Update Rate: 50 Hz

Frame: Sensor 1 Sensor 2

Formula Select: SIMRAD 3000 (TSS)

Roll Positive Sense: Port Up Starboard Up

Pitch Positive Sense: Bow Up Stern Up

Heave Positive Sense: Heave Up Heave Down

Input Select: None

Close Apply

COM3

Input/Output Ports Set-up

COM1 | COM2 | **COM3** | COM4 | COM5

Baud Rate: 4800

Parity: None Even Odd

Data Bits: 7 Bits 8 Bits

Stop Bits: 1 Bit 2 Bits

Flow Control: None Hardware XON/XOFF

Output Select: None

Input Select: Base 1 GPS

Base GPS Input: Input Type: RTCM 1 or 9

Line: Serial Modem

Modem Settings

Close Apply

COM4

Input/Output Ports Set-up

COM1 | COM2 | COM3 | **COM4** | COM5

Baud Rate: 4800

Parity: None Even Odd

Data Bits: 7 Bits 8 Bits

Stop Bits: 1 Bit 2 Bits

Flow Control: None Hardware XON/XOFF

Output Select: NMEA

NMEA Output:

- \$GPGST
- \$GPGGA
- \$GPHDT
- \$GPZDA
- \$GPRVTG
- \$PASHR

Update Rate: 2 Hz

Talker ID: GP

Roll Positive Sense: Port Up Starboard Up

Pitch Positive Sense: Bow Up Stern Up

Heave Positive Sense: Heave Up Heave Down

Input Select: None

Close Apply

COM5

Input/Output Ports Set-up

COM1 | COM2 | COM3 | COM4 | **COM5**

Baud Rate: 9600

Parity: None Even Odd

Data Bits: 7 Bits 8 Bits

Stop Bits: 1 Bit 2 Bits

Flow Control: None Hardware XON/XOFF

Output Select: NMEA

NMEA Output:

- \$INGST
- \$INGGA
- \$INHDT
- \$INZDA
- \$INVTG
- \$PASHR

Update Rate: 1 Hz

Talker ID: IN

Roll Positive Sense: Port Up Starboard Up

Pitch Positive Sense: Bow Up Stern Up

Heave Positive Sense: Heave Up Heave Down

Input Select: None

Close Apply

SETTINGS Continued

Heave Filter

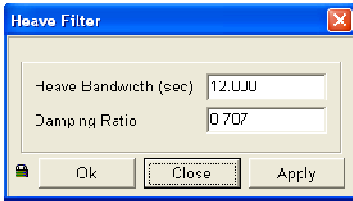

Heave Filter dialog box with the following fields:

Heave Bandwidth (sec)	12.000
Damping Ratio	0.707

Buttons: Ok, Close, Apply

Events

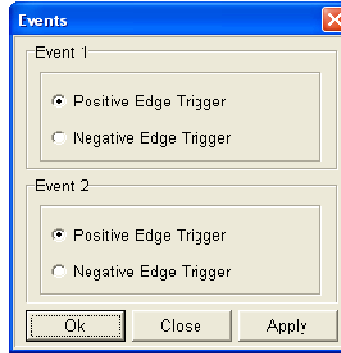

Events dialog box with two event configurations:

Event 1

- Positive Edge Trigger
- Negative Edge Trigger

Event 2

- Positive Edge Trigger
- Negative Edge Trigger

Buttons: Ok, Close, Apply

INSTALLATION

(Use Settings > Installation)

Lever Arms and Mounting Angles

(Use Settings > Installation > Lever Arms and Offsets)

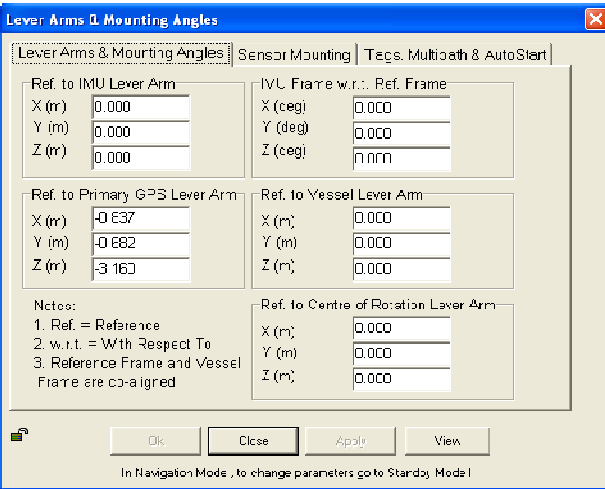

Lever Arms & Mounting Angles dialog box with the following sections:

- Lever Arms & Mounting Angles** (selected tab)
- Sensor Mounting**
- Tags, Multipath & AutoStart**

Ref. to IMU Lever Arm

X (m)	0.000
Y (m)	0.000
Z (m)	0.000

Ref. to Primary GPS Lever Arm

X (m)	-0.837
Y (m)	-0.682
Z (m)	-3.163

Ref. to Yessel Lever Arm

X (m)	0.000
Y (m)	0.000
Z (m)	0.000

Ref. to Centre of Rotation Lever Arm

X (m)	0.000
Y (m)	0.000
Z (m)	0.000

IVL Frame w.r.t. Ref. Frame

X (deg)	0.000
Y (deg)	0.000
Z (deg)	0.000

Notes:

1. Ref. = Reference
2. w.r.t. = With Respect To
3. Reference Frame and Vessel Frame are co-aligned

Buttons: Ok, Close, Apply, View

In Navigation Mode, to change parameters go to Standby Mode!

Tags, Multipath and Auto Start

(Use Settings > Installation > Tags, Multipath and Auto Start)

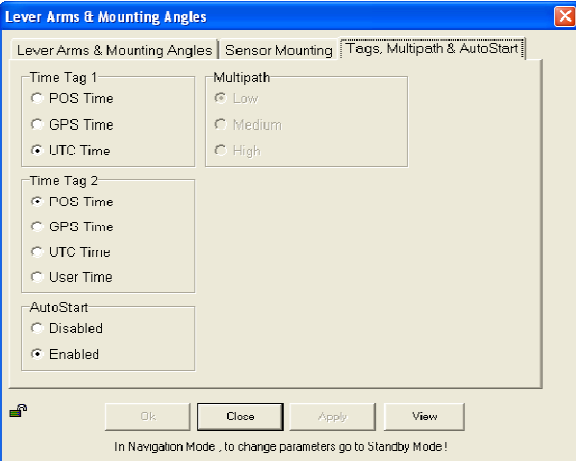

Tags, Multipath and Auto Start dialog box with the following sections:

- Tags, Multipath & AutoStart** (selected tab)

Time Tag 1

- POS Time
- GPS Time
- UTC Time

Time Tag 2

- POS Time
- GPS Time
- UTC Time
- User Time

AutoStart

- Disabled
- Enabled

Multipath

- Low
- Medium
- High

Buttons: Ok, Close, Apply, View

In Navigation Mode, to change parameters go to Standby Mode!

Sensor Mounting

(Use Settings > Installation > Sensor Mounting)

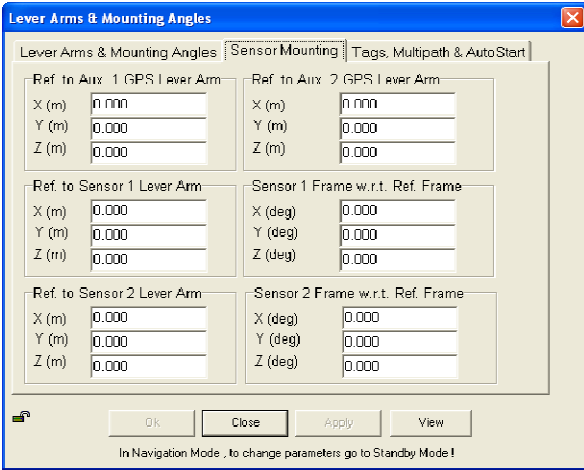

User Parameter Accuracy

(Use Settings > Installation > User Accuracy)

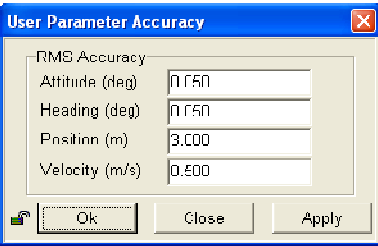

Frame Control

(Use Tools > Config)

<input type="checkbox"/>	User Frame	<input type="checkbox"/>	Primary GPS Measurement
<input type="checkbox"/>	IMU Frame	<input type="checkbox"/>	Auxiliary GPS Measurement
<input type="checkbox"/>	Use GAMS enabled		

GPS Receiver Configuration

(Use Settings> Installation> GPS Receiver Configuration)

Primary GPS Receiver

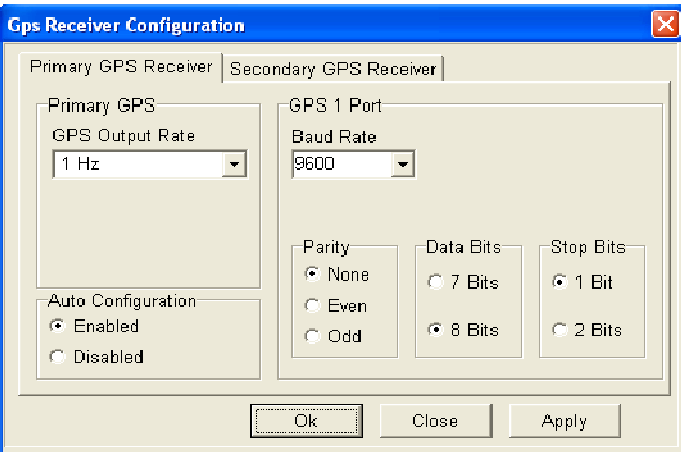

Secondary GPS Receiver

Post Processing of GAMS Calibration Processing Log

3/29/2012	089	ENS Smith, ENS Flowers
Date	Dn	Personnel
<input checked="" type="checkbox"/>	POS Pac Processing	Allow decimeter level freedom when processing
<input checked="" type="checkbox"/>		Reprocess using new values, but restrict to 10 cm of freedom
<input checked="" type="checkbox"/>		Reprocess using new values, again use 10 cm of freedom
<input checked="" type="checkbox"/>		Continue iterating until values no longer change
	Final Antena Seperation/ Lever Arms Determined <input checked="" type="checkbox"/>	See FOO/CST with values
	New Values entered in POS View? <input type="checkbox"/>	Values

GAMS Calibration Post-Processing Results

Date: 3/28/2012 Dn: 088
Vessel: 2808
POS File Name: 2012_088_2808.000
POSPac Project Name: 2012_088_2808_GAMS
Project Location: Yaquina Bay

Lever Arm Offsets

(Project Settings > GNSS-Inertial Processor > Lever Arms and Mounting Angles)

	X	Y	Z
Reference to IMU Lever Arm	-0.008	-0.031	0.130

	X	Y	Z
Starting Value (Reference to Primary GNSS Lever Arm)	-0.725	-0.72	-3.17

Trailing 10 Minute Average Using Pydro Macro

(W:\Control\HorCon\Pubs-Refs\Scripts\CalcOUTstats.py)

	X	Y	Z
Run 1	-0.727	-0.718	-3.17
Run 2	-0.727	-0.718	-3.17
Run 3			

GAMS Calibration Results

Two Antenna Separation (m) **1.453**

ERDDM Acquisition Log

Launch 2808 200kHz

Vessel

4/14/2012	105	Shilshole	0-1 ft chop
Date	Dn	Local Area	Wx

SS Marcum, ENS Smith, AST Marcus, AST Bowker

Personnel

Comments

slack 1140 local time	Robinson Point, WA - 323 kHz (200 BPS)
Tidal Cycle Notes	USCG DGPS Beacon Used

POSMV filename(s)

POS File	Azmuth	Vessel Speed	RPM	Start and End Time
2012_105_2808.104		5 minute wait		1808 start, 1814
2012_105_2808.105	013		04	1814 start, 1819
2012_105_2808.106	013		06	1819 start, 1824
2012_105_2808.106	013		08	1824 Start, 1829
2012_105_2808.107	013		010	1829 start, 1834
2012_105_2808.108	193		010	1834 start, 1840
2012_105_2808.109	193		08	1840 start, 1844
2012_105_2808.109	193		06	1844 start, 1849
2012_105_2808.110	193		04	1849 start, 1856
2012_105_2808.111, 112		5 minute wait		1856 start, 1901

Processing Log

4/15/2012	106	ENS Smith
Date	Dn	Personnel

POS Files Processed in POS Pac Smartbase - (P426, SEAI, RPT5, PRDY, KTBW)
Smartbase or Singlebase? Station used.

SBET Processed in Pydro Using the ERDDM Tool

Graph and Table Values compared with previous year

Documentaion Complete in DAPR Appendix

See OPS/CST for updating HVF with new values

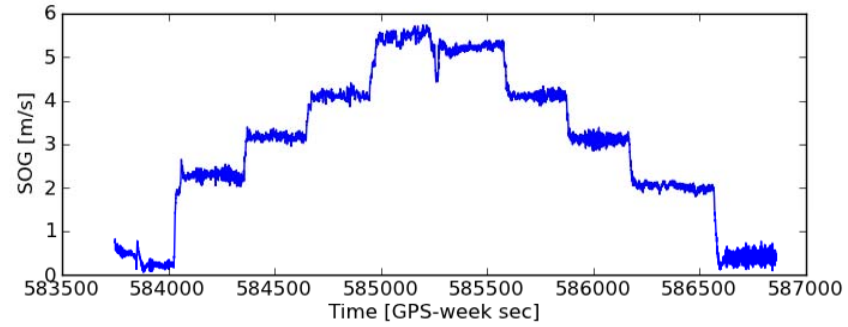
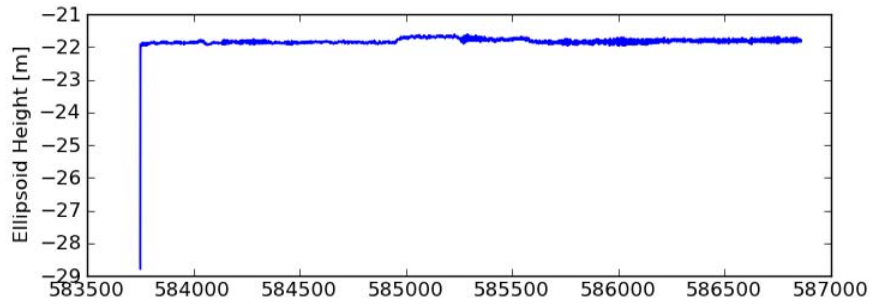

$$-0.00697 * X^3 + 0.0484 * X^2 - 0.0885 * X$$

Speed [m/s]	Delta Draft [m]
0.00	0.00
0.50	-0.03
1.00	-0.05
1.50	-0.05
2.00	-0.04
2.50	-0.03
3.00	-0.02
3.50	-0.02
4.00	-0.03
4.50	-0.05
5.00	-0.11
5.50	-0.18
6.00	-0.30

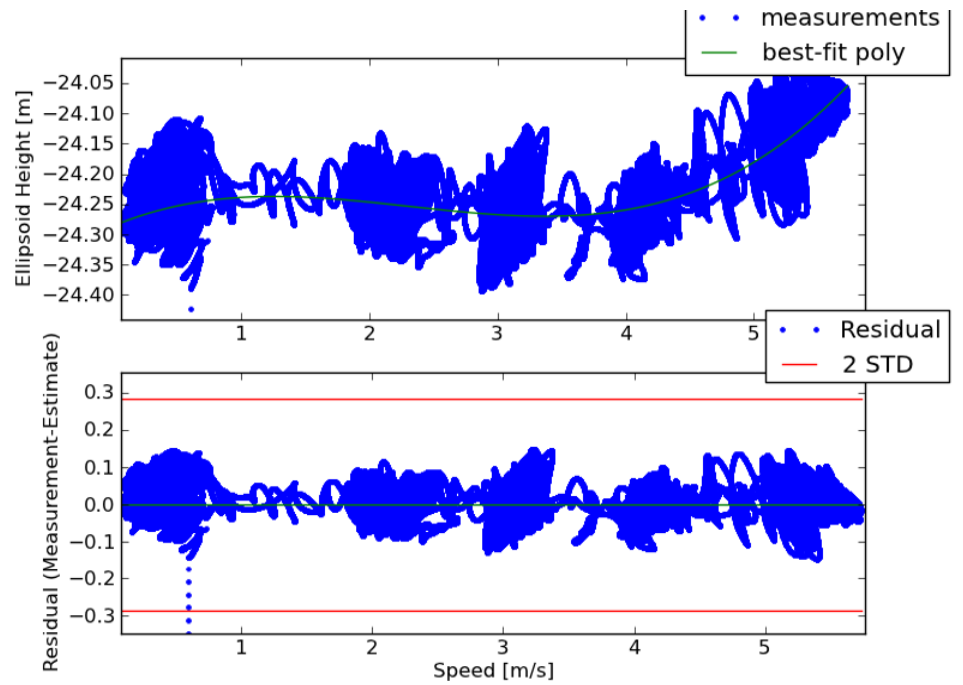
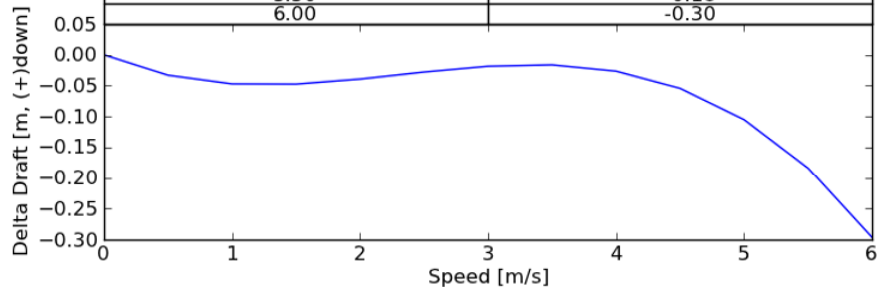

S220 Offsets and Measurements - Summary

Measurement Coord. Sys.	IMU to 7/8111 (MRU to Trans)		Port Ant to 7/8111 (Nav to Trans)		Waterline to RP*		Port Ant to Stbd Ant		IMU to Port Ant		IMU to Heave	
	Caris		Caris		Caris				Caris	Pos/Mv	Caris	Pos/Mv
x	2.868	2.071	n/a	Scaler Distance	1.997	0.797	-11.892	1.866	-7.028			
y	8.252	20.144	n/a			-11.892	0.797	-7.028	1.866			
z	4.752	17.821	0.081			13.068	-13.068	-2.086	-2.086			

*Top of IMU is RP (Reference Pt)

Vessel Offsets for S220 7111 are derived from Westlake Survey Report NOAA Fairweather 09-23-03, Fairweather Centerline Survey (NGS) Report March 2009, and measurements by FA personnel in 2010 and 2011.

Calculations

Coordinate Systems used as listed	IMU to 7/8111		Port Ant to 7/8111		Waterline to RP*		Port Ant to Stbd Ant		IMU to Port Ant		IMU to Heave						
	Westlake		NGS		Westlake		NGS		NGS		Westlake						
IMU Base	easting	0.000	Top of IMU to Port Ant	x	-11.892	IMU Base to baseline at Keel (ft) elevation	12.856	Phase Center Port Ant	x	-11.892	IMU Top (m)	x	0.000	IMU to Bulkhd (Frame) 52 (ft) easting	-11.638	IMU Base to baseline at Keel (ft) elevation	12.856
	northing	0.000		y	0.797	IMU Base to baseline at Keel (m) elevation	3.919		y	0.797		y	0.000	(m) easting	-3.547	(m) elevation	3.919
	(ft/m) elevation	0.000		(m)	z	13.068			(m)	z	13.068		z	0.000			
8111 (from IMU Base to sensor)			CARIS											Frame 0 (FP) to Frame 52 (m) easting	-27.737	Top of IMU to Base of IMU (m) elevation	0.168
easting	27.072		Port Ant	x	0.797	Waterline to Keel (ft) elevation	13.67	Top of old Stbd Ant (pre-2010)	x	-11.886	Top of old Port Ant (pre-2010)	x	-11.892			Top of IMU to Keel (m) elevation	4.086
(ft) northing	9.410			y	-11.892	Waterline to Keel (m) elevation	4.167		y	2.794		y	0.797	IMU to Frame 0 (FP) (m) easting	24.190		
elevation	15.042		(m)	z	-13.068	See Ship's Draft Spreadsheet		Top to Base of Old (pre-2010) Ant measured (in)	z	2.477	Top to Base of Old (pre-2010) Ant measured (in)	z	2.477	Heave Pt* to Frame 0 (FP) (ft) easting	102.42	Center of Gravity above baseline (ft) elevation	16.37
8111 (from IMU Base to sensor)			Westlake											(m) easting	31.218	Mean Metacentric height (ft) elevation	3.88
easting	8.252		(m) easting		8.252	Top of IMU to Base of IMU (m) elevation	0.168	Top of Stbd Ant Post	x	-11.886	Top of Port Ant Post	x	-11.892	IMU to Centerline (ft) northing	6.122	Heave Pt* to baseline at Keel (ft) elevation	20.25
(m) northing	2.868		Top of IMU to 8111	northing	2.868	Top of IMU to Keel (m)	4.086		y	2.794		y	0.797	(m) northing	1.866	(m) elevation	6.172
elevation	4.585			elevation	4.752			Base to Phase Ctr New(2010) Ant listed on Ant(m)	z	12.988	Base to Phase Ctr New(2010) Ant listed on Ant (m)	z	12.984	(m) northing	1.866		
Base of IMU to Top of IMU (m) elevation	-0.168		CARIS	(m)	x	2.868			(m)	z	0.0843	Base to Phase Ctr New(2010) Ant listed on Ant (m)	z	0.0843	Heave Pt* to Centerline (m) northing	0	(*Heave Pt is Metacenter) (FP is Forward Perpendicular)
2010 value -> Correction based on Ref Surface -0.322 (m) elevation	0			Top of IMU to 8111	z	4.752											

IMU to 7/8111		Port Ant to 7/8111		Waterline to RP*		Stbd Antenna		IMU to Port Ant		IMU to Heave					
Westlake	easting	8.252	CARIS	x	2.071	Westlake	easting	N/A	NGS	(m)	x	-11.892	Westlake	easting	-7.028
Top-IMU to 8111 (m) elevation	northing	2.868		y	20.144	Waterline to IMU (m) elevation	0.081	Top of IMU to Stbd Ant (aka Stbd Ant Phase Center)	y	0.797	Top of IMU to Port Ant (aka Port Ant Phase Center)	y	0.797	Top-IMU to Heave (ft) northing	1.866
		4.752	(m)	z	17.821				z	13.072		z	13.068	Heave Pt* (r) elevation	-2.086
Coord Sys. CARIS			Coord Sys. CARIS			Coord. Sys CARIS					Coord Sys. POS/MV			(*see Description Tab)	
x	2.868		x	2.071		x	N/A	Port Ant to Stbd Ant	x	-11.892	x	-11.892	x	-7.028	
y	8.252		y	20.144		y	N/A	Scalar Distance (m)	y	0.797	y	0.797	y	1.866	
z	4.752		z	17.821		z	0.081		z	-13.068	z	-13.068	z	-2.086	

S220 Offsets and Measurements - Summary

Measurement	IMU to 8160 (MRU to Trans)		Port Ant to 8160 (Nav to Trans)		Waterline to RP*		Port Ant to Stbd Ant		IMU to Port Ant		IMU to Heave	
Coord. Sys.	Caris		Caris		Caris		Scaler Distance		Caris	Pos/Mv	Caris	Pos/Mv
x		0.493		-0.304		n/a		1.997	0.797	-11.892	1.866	-7.028
y		7.665		19.557		n/a			-11.892	0.797	-7.028	1.866
z		4.726		17.794		0.081			13.068	-13.068	-2.086	-2.086

*Top of IMU is RP (Reference Pt)

Vessel Offsets for S220 8160 are derived from Westlake Survey Report NOAA Fairweather 09-23-03, Fairweather Centerline Survey (NGS) Report March 2009, and measurements by FA personnel.

Derivations

Coord. Sys.	IMU to 8160		Port Ant to 8160	
	Westlake		NGS 2009	
IMU	easting	0.000	Top of IMU	x -11.892
Base	northing	0.000	to Port Ant	y 0.797
	(ft/m) elevation	0.000	(m)	z 13.068
8160 (from IMU Base to sensor)	CARIS		CARIS	
	easting	25.149	Port	x 0.797
	(ft) northing	1.619	Ant	y -11.892
	elevation	14.956	(m)	z -13.068
8160 (from IMU Base to sensor)	Westlake		Westlake	
	(m) easting	7.665	(m) easting	7.665
	(m) northing	0.493	Top of IMU northing	0.493
	elevation	4.559	to 8160 elevation	4.726
Base of IMU to Top of IMU	CARIS		CARIS	
	(m) elevation	-0.168	(m)	x 0.493
			Top of IMU	y 7.665
2010 value -> Correction based on Ref Surface			to 8160	z 4.726
-0.206	(m) elevation	0		

	IMU to 8160		Port Ant to 8160	
	Westlake		CARIS	
Top of IMU	easting	7.665	(m)	x -0.304
to 8160 (m)	northing	0.493		y 19.557
	elevation	4.726	(m)	z 17.794
Coord Sys	CARIS		CARIS	
	x	0.493	x	-0.304
	y	7.665	y	19.557
	z	4.726	z	17.794

S220 Offsets and Measurements - Summary

Measurement aka Coord. Sys.	IMU to RP*	IMU to TOW PT K5K	Caris
x	0.000		1.866
y	0.000		-42.642
z	0.000		-7.402

*IMU is Reference Point

Vessel Offsets for S220 Tow Point are derived from Fairweather Centerline Survey (NGS) Report March 2009, and

2011 Measured Values.

Calculations

Coord. Sys./

Source

NGS

IMU to TOW PT K5K			
IMU (m)	x	0.00000	
	y	0.00000	
	z	0.00000	

A-FRAME PIVOT STBD (m)

x	-39.727
y	3.366
z	2.385

A-FRAME PIVOT STBD

to TOW PT	x	-2.915
(measured)	y	-1.500
	z	5.017

Coord. Sys.

NGS

IMU to TOW PT K5K			
IMU to	x	-42.642	
TOW PT	y	1.866	
	z	7.402	

Coord. Sys.	x	1.866
CARIS	y	-42.642
	z	-7.402

Description of Offsets for FAIRWEATHER S-220

All Values Shown are in CARIS Coordinates

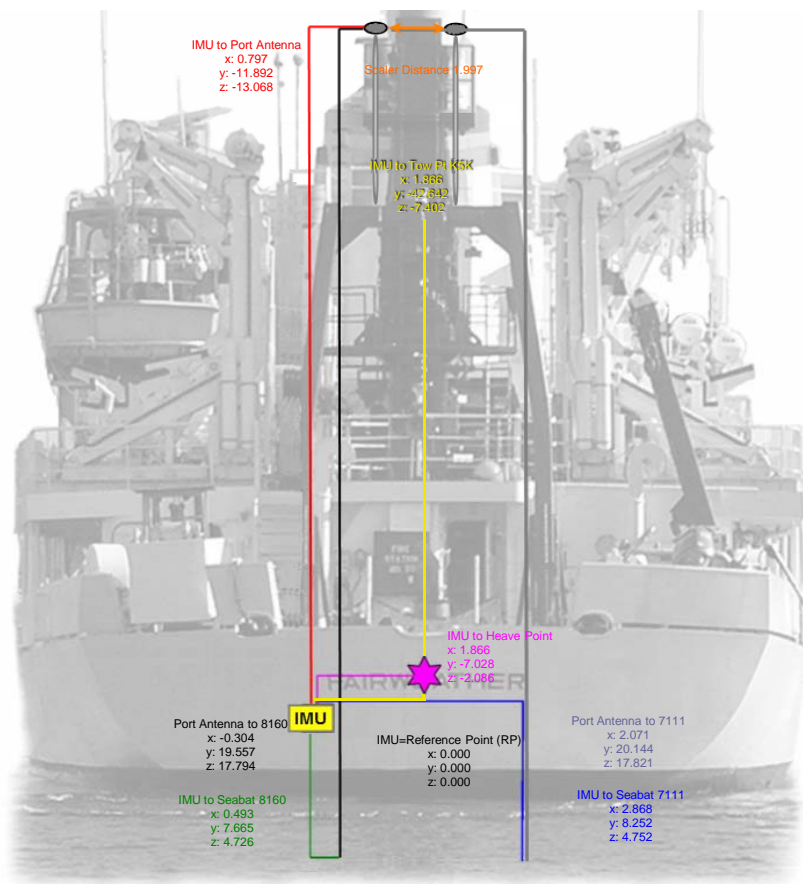
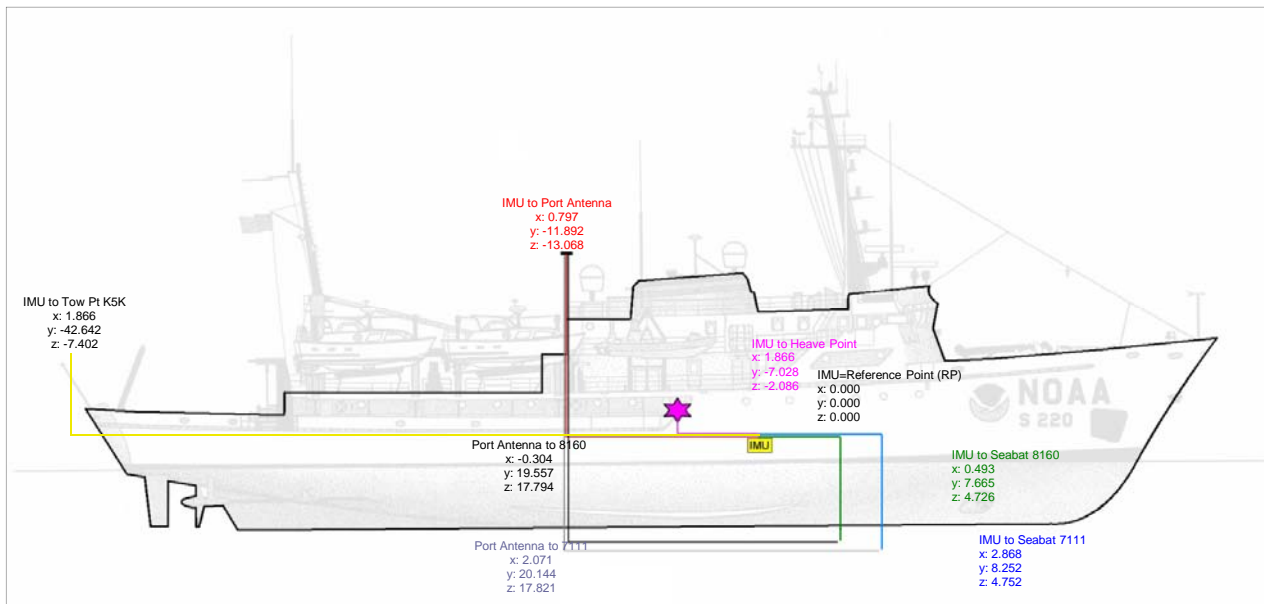

IMU to 7/8111 (MRU to Trans)		
x	y	z
2.868	8.252	4.752

The lever arms between the IMU and phase center of the 7111 transducer are taken from the Westlake report along with the the -0.168 m offset included for the height of the IMU.

IMU to 8160 (MRU to Trans)		
x	y	z
0.493	7.665	4.726

The lever arms between the IMU and phase center of the 8160 transducer are taken from the Westlake report with the addition of the -0.168 m offset included for the height of the IMU.

IMU to TOW PT K5K		
x	y	z
1.866	-42.642	-7.402

The offsets were determined using the NGS 2009 survey values for the A-Frame Stbd Pivot and measurements by FA personnel. Measurements between the A-Frame Pivot and the Tow point were made with a steel tape and digital level to determine the deployed angle of the A-Frame.

Port Ant to 7/8111 (Nav to Trans)		
x	y	z
2.071	20.144	17.821

Relative positions obtained from Port Ant to 7/8111 via IMU.

Port Ant to 8160 (Nav to Trans)		
x	y	z
-0.304	19.557	17.794

Relative positions obtained from Port Ant to 7/8111 via IMU.

Port Ant to Stbd Ant	
Scaler Distance	1.997

Using the NGS 2009 survey values for the antennas, a calculated vector for antenna separation was determined. The distance from Top of Antenna to Phase Center does not affect this calculation and therefore was not included.

IMU to Port Ant		
x	y	z
0.797	-11.892	13.068

This information comes from a combination of the Westlake, NGS surveys, and measurements by FA personnel. The NGS 2009 survey was to the top of the antenna, that distance (z-value) was measured in 2010 and subtracted to get the xyz of the antenna post. Then the distance (z-value) up to the phase center to the new 2010 antenna was added to obtain the xyz of the phase center of the newly installed (May2010) antenna.

Waterline to RP*		
x	y	z
n/a	n/a	0.081

The height of the IMU above the keel comes from the Westlake survey value of 3.919 m plus the measured value of the top of the IMU to the base plate, to get an IMU height above the keel. The draft (waterline to keel) used for the FAIRWEATHER is based on observations, Ship's Draft spreadsheet. Differencing the value of IMU to keel and waterline to keel gives the waterline to RP distance.

IMU to Heave		
x	y	z
1.866	-7.028	-2.086

Key points on the IMU, from the Westlake survey, are its location with respect to the ship's reference frame. It is 4.087 m (3.919 m to base line + 0.168 m for IMU height above base plate) above the keel, 1.866 m port of centerline and 3.547 m forward of frame 52. This information is needed to reference the IMU to the ship's Heave Measurement Location (Heave Point). *

IMU to Heave	
From pg 3 of the Westlake Survey	

SUMMARY

- IMU foundation plate is level to within +/-0.001 feet.
- IMU foundation plate is located 12.856 feet above baseline established at the keel.
- IMU is parallel to ship's centerline to within +/- 0.001 feet. Location of scribed centerline intersection is 6.122 feet port of ship's centerline.
- IMU foundation plate centerline is located 11.638' feet forward of bulkhead 52.

IMU to Heave

* From the Art Anderson inclination experiment the position of the metacenter was used as the position of the ship's Heave Point. (There may be a better way to determine the Heave Point, but this decision was based upon available information). The metacenter is defined by the center of buoyancy. As a vessel inclines through small angles, the center of buoyancy moves through the arc of a circle whose center is at the metacenter.

Important numbers and information determined from the Art Anderson report are the location of the metacenter and how it is positioned with respect to the vessel. The longitudinal location of the metacenter is defined as 102.42 feet (31.217 m) aft of the forward perpendicular. The height of the metacenter is 20.25 feet (6.172 m) above the keel. There is an assumption of the metacenter being on the centerline of the vessel. Similar values for the RAINIER's metacenter are 32.52 m aft of the forward perpendicular and 5.2 m above the keel. The difference in the height of the metacenter can be attributed to the difference between the FA's and RA's average draft which is 13.12 feet as opposed to approximately 14.5 feet respectively.

Referencing the metacenter (Heave Point, HP) to the IMU information requires information about the frame spacing of the vessel. From the Westlake survey, the IMU is located 3.547 m forward of frame 52. From Inclination document, the HP is 31.217 m aft of the forward perpendicular. From engineering drawings of the ship frame spacing is approximately 21 inches. The calculation for the longitudinal location of the HP with respect to frame zero, the Forward Perpendicular (FP) is as follows:

$$52 \text{ (frame)} * 21 \text{ (inches/frame)} / 12 \text{ (inches/ft)} * .3048 \text{ (m/ft)} - 3.547 \text{ m} = 24.190 \text{ m from frame 0.}$$

$$31.217 \text{ m (HP aft of FP)} - 24.190 \text{ m (IMU aft of FP)} = 7.027 \text{ m (HP aft of IMU)}$$

The calculation for the vertical separation between the IMU and the HP is based on the height of the metacenter being 6.172m and the height of the IMU being 4.087 m above the keel. Differencing yields the metacenter being 2.085 m above the IMU.

The calculation for the athwartship separation is based upon the assumption that the HP is on the centerline and the knowledge that the IMU is 1.866 m to port of the centerline.

Sources

Offset values for the ship were derived from three sources. Three static offset surveys, an inclination experiment, and values measured or approximated by ship's personnel.

On September 23, 2003 an offset survey of the NOAA Ship FAIRWEATHER was conducted by:

Westlake Consultants, Incorporated
15115 SW Sequoia Parkway, Suite 150
Tigard, Oregon 97224
Phone (503) 684-0652

The relocation of the POS M/V antenna forced a partial resurvey in Feb-2007 by Steven Breidenbach of NGS (values no longer utilized).

While in drydock, another NGS (Centerline) survey was conducted March, 2009.

These values relate the physical positions of one sensor to the next with the base plate of the IMU being the point of origin. All dimensions in the document are given in feet and decimal feet.

On July 16, 2004 an inclination experiment was conducted at MOC-P by:

Art Anderson Associates
202 Pacific Avenue
Bremerton, WA 98337-1932

Calculations

The values for the required lever arms are listed in the S220_Offsets and Measurements spreadsheet. The reference point and the IMU are identical. Difference in documentation between Westlake and FA calculations are based off of measuring up from the IMU base (Westlake's origin) and the top of the IMU. The top center of the IMU for the POS/MV is the defined origin for the POS/MV and the origin that is being used on all FAIRWEATHER vessels. The distance from the base plate to the top of the IMU is 0.168 m, a value measured by ship's complement. Conversion factor from feet to meters is 0.3048 m/ft.

As a requirement for the TPU, the standard deviation for each position is 3 mm. This value is based upon a conversation with Elaine McDonald of Westlake and is followed up by an Email documenting that fact. The email is located at the end of this document.

Fairweather Draft - 2012

Immediately prior to the FA field season, the draft measurements were taken prior to fueling when the tanks were very empty (Empty) . And again after fueling and once the engineers had transferred the fuel in a satisfactory manner (Full) . The waterline at the IMU was then calculated based on a linear interpolation.

2012		x1	Fwd y1	x2	Aft y2	slope	IMU Depth (ft)	IMU Depth (m)	Min	Max
ave 40-45	Empty - Port	5.25	13.28	189	13.11	-0.00093	13.21	4.027	13.08	14.39
ave 40-45	Empty - Stbd	5.25	13.20	189	13.08	-0.00065	13.15	4.009		
ave 90's	Full - Port	5.25	13.53	189	14.39	0.00468	13.88	4.230		
ave 90's	Full - Stbd	5.25	13.56	189	14.14	0.00316	13.79	4.204		
Description (ie empty, full)		5.25		189		0.00000	0.00	0.000		

The IMU	x-value (ft):	79.36	Draft at IMU (ft)	13.51	4.117	AVG	Value Used in Offsets
	x-value (m):	24.19		0.380	0.116	STDEV	Value used for Waterline Loading Uncertainty

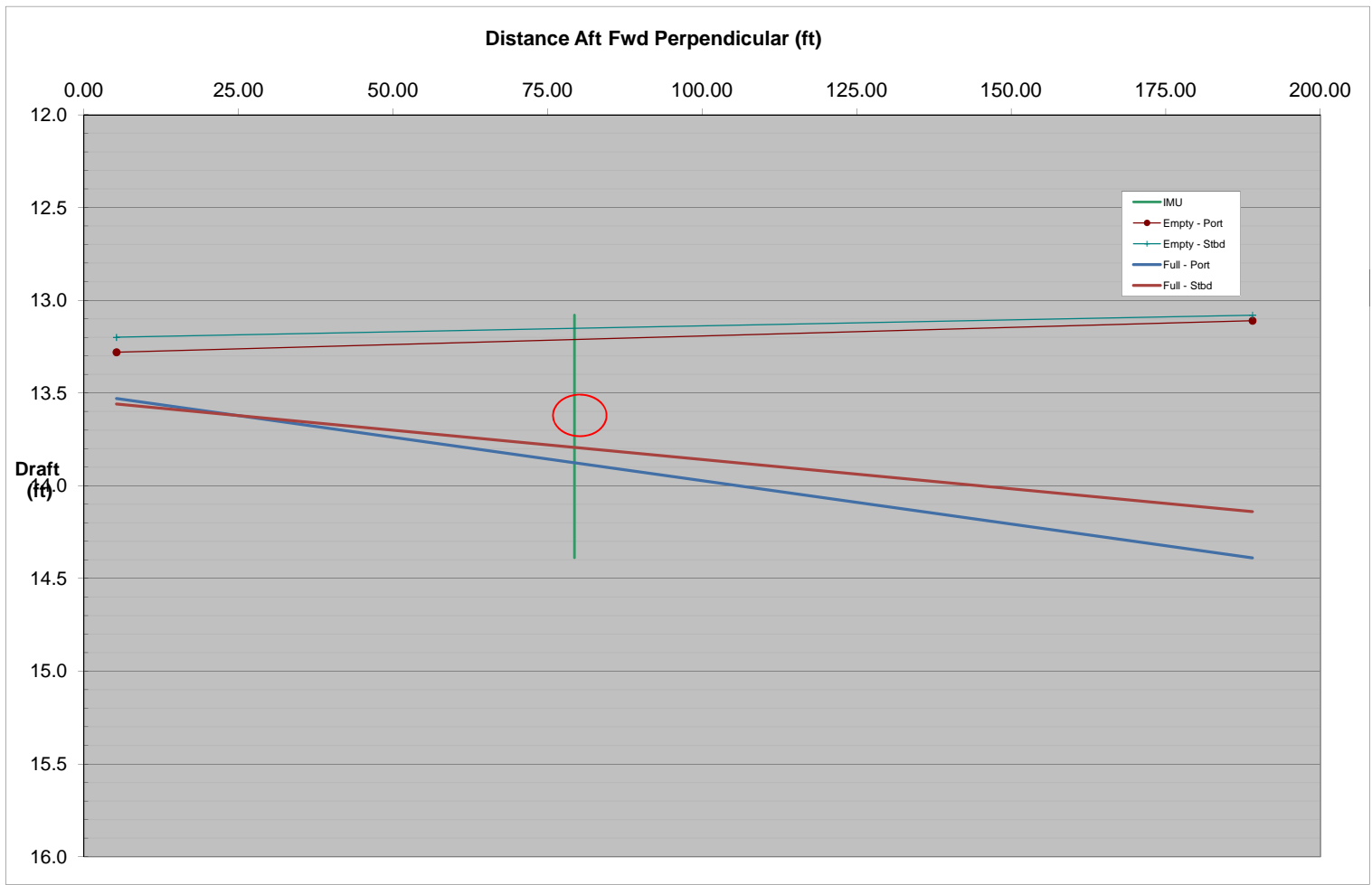

US DEPARTMENT OF COMMERCE
NATIONAL OCEANIC & ATMOSPHERIC ADMINISTRATION
NATIONAL OCEAN SERVICE
NATIONAL GEODETIC SURVEY
GEODETIC SERVICES DIVISION
INSTRUMENTATION & METHODOLOGIES BRANCH

**NOAA SHIP FAIRWEATHER
POS MV COMPONENTS SPATIAL RELATIONSHIP SURVEY
FIELD REPORT**

Kendall Fancher
March , 2009

PRIMARY CONTACTS

Glen Rice

NOAA 757-615-6465

NOAA SHIP FAIRWEATHER POS MV COMPONENTS SPATIAL RELATIONSHIP SURVEY

PURPOSE

The primary purpose of the survey was to precisely determine the spatial relationship of various components of a POS MV navigation system aboard the NOAA ship FAIRWEATHER. Additionally, various reference points (bench marks) were re-established onboard the vessel to aid in future spatial surveys aboard the boat.

PROJECT DETAILS

This survey was conducted while the ship was in dry dock at the Lake Union dry dock in Seattle, WA. The weather conditions over the two days required to conduct this survey were windy, cool, with intermittent rain.

INSTRUMENTATION

The Leica TC2003 total station was used to make all measurements.

Technical Data:

Standard Deviation	
Horizontal angle	0.5 seconds
Vertical angle	0.5 seconds
Distance measurement	0.2mm + 2ppm

A Leica precision prism was used as a sighting target. This prism was configured to have a zero mm offset.

PERSONNEL

Kendall Fancher	NOAA/NOS/NGS/GSD/I&M BRANCH (540) 373-1243
Dennis Lokken	NOAA/NOS/NGS/GSD/I&M BRANCH (540) 373-1243

NOAA SHIP FAIRWEATHER POS MV COMPONENTS SPATIAL RELATIONSHIP SURVEY

DEFINITION OF THE REFERENCE FRAME

To conduct this survey a local coordinate reference frame was established where the Northing (Y) axis runs along the centerline of the ship and is positive from the IMU towards the bow of the ship. The Easting (X) axis is perpendicular to the centerline of the ship and is positive from the IMU towards the right, when looking at the ship from the stern. The Up (Z) axis is positive in an upward direction from the IMU.

SURVEY METHODOLOGY

02/15/2009

Coordinates of 100.000N, 100.000E, and 100.000U were assumed for temporary control point 1. A distance and height difference were measured between temporary control points 1 and 3. These values were used to determine the coordinates at temporary control point 3. Temporary control points 1 and 3 were located along the top deck and on the north side of the dry dock vessel.

Temporary control point 1 was occupied and temporary control point 3 was observed for a backsight. After initialization, temporary control points 2 and 4 (located on the top deck of the dry dock vessel), H1 (located on the bottom deck of the dry dock vessel), and BOW BM were observed in both direct and reverse.

Temporary control point 2 was occupied and temporary control point 3 was observed for a backsight. After initialization, temporary control point W1 (located on the top deck of the dry dock vessel) and D1 (located inside the ship on the D deck along the port side) were observed in both direct and reverse. Temporary control point 1 was also observed and yielded an inverse check of 0.001m horizontally and 0.001m vertically.

Temporary control point 4 was occupied and control point 1 was observed for a backsight. After initialization, temporary control point 5 (located on the south side and on the top deck of the dry dock vessel) was observed in both direct and reverse.

Temporary control point 5 was occupied and control point 4 was observed for a backsight. After initialization, temporary control point D2 (located inside the ship on the D deck along the starboard side) was observed in both direct and reverse.

Temporary control point H1 was occupied and control point 1 was observed for a backsight. After initialization, temporary control point H2 (located on the bottom deck of the dry dock vessel), and USBL BM were observed in both direct and reverse.

Temporary control point H2 was occupied and temporary control point H1 was observed for a backsight. After initialization, 8111 BM and 8160 BM were observed in both direct and reverse. Temporary control point W1 was also observed and yielded an inverse check of 0.019m horizontally and 0.033m vertically.

Temporary control point D1 was occupied and temporary control point D2 was observed for a backsight. After initialization, temporary control point D3 (located in the doorway leading to the mess hall on the D deck) was observed in both direct and reverse.

Temporary control point D3 was occupied and temporary control point D1 was observed for a backsight. After initialization, temporary control point C1 (located on the C deck near the IMU) was observed in both direct and reverse. Temporary control point D2 was also observed and yielded an inverse check of 0.026m horizontally and 0.0001m vertically.

Temporary control point C1 was occupied and temporary control point D3 was observed for a backsight. After initialization, IMU, IMU BOW PORT CORNER, IMU BOW STAR CORNER, IMU STERN STAR CORNER, and IMU STERN PORT CORNER were observed in both direct and reverse.

02/16/2009

Temporary control point 4 was occupied and control point 1 was observed for a backsight. After initialization, temporary control point 6 (located on the south side and on the top deck of the dry dock vessel) and BOW BM were observed in both direct and reverse. Temporary control point D2 was also observed and yielded an inverse check of 0.0004m horizontally and 0.083m vertically.

Temporary control point 6 was occupied and temporary control point 4 was observed for a backsight. After initialization, TRANSOM PIVOT POINT PORT, STERN BM, POS GPS ANT RAIL BM, POS IMU ANT DECK BM, POS GPS ANT STARBOARD, and POS GPS ANT PORT were observed in both direct and reverse.

Temporary control point 3 was occupied and temporary control point 1 was observed for a backsight. After initialization, TRANSOM PIVOT POINT STARBOARD, STERN BM, POS GPS ANT STARBOARD, and POS GPS ANT PORT were observed in both direct and reverse. Temporary control point 6 was also observed and yielded an inverse check of 0.0006m horizontally and 0.001m vertically.

The reference frame was rotated using STERN BM as the point of rotation. A zero degree azimuth was used during the rotation from STERN BM to BOW BM. The reference frame was then translated to relocate the origin of the reference frame to the IMU.

**NOAA SHIP FAIRWEATHER
POS MV COMPONENTS SPATIAL RELATIONSHIP SURVEY**

INVERSE RESULTS

Inverses were computed between the determined positions of those ship benchmarks and sensor points which were determined from two separate locations. The results of these inverses are:

ID	Horizontal Dist.(m)	Elevation Diff(m)
BOW BM	0.0150	0.0240
STERN BM	0.0060	0.0010
POS GPS ANT STARBOARD	0.0100	0.0001
POS GPS ANT PORT	0.0100	0.0000

DISCUSSION

The Fairweather was in dry dock during this survey, however, the dry dock vessel was still subject to movement due to wave action. Conducting a survey such as this while the ship is moving requires that the automatic compensators in the survey instrument be turned off. The survey is therefore conducted with all survey instrumentation set up relative to the mean movement of the related level vials. While every effort was made to make the most precise measurements possible, some additional error accumulation cannot be avoided under these type observing conditions.

The POS GPS antenna coordinates were determined to the top center of the antennas. The Z value should be corrected to the Antenna Reference Point (ARP). In order to apply this correction, the mechanical height of the antenna should be determined and subtracted from the Z value determined during this survey for both of the POS GPS antennas.

**NOAA SHIP FAIRWEATHER
POS MV COMPONENTS SPATIAL RELATIONSHIP SURVEY**

Coordinate Listing using IMU as the Reference Frame Origin

ID	X(NORTHING)m	Y(EASTING)m	Z(UP)m
IMU CENTER	0.000	0.000	0.000
IMU STERN PORT CORNER	-0.071	-0.089	-0.001
IMU BOW PORT CORNER	0.070	-0.086	-0.001
IMU BOW STARBOARD CORNER	0.069	0.087	0.000
IMU STERN STARBOARD CORNER	-0.073	0.086	0.000
BOW BM	28.378	1.805	7.796
STERN BM	-40.306	1.805	2.255
USBL BM	-28.354	1.738	-4.204
8160 BM	8.407	0.395	-4.400
8111 BM	8.532	3.002	-4.666
POS GPS ANT RAIL BM	-12.011	1.785	10.381
POS IMU ANT DECK BM	-11.790	1.780	9.305
POS GPS ANT STARBOARD	-11.886	2.794	13.051
POS GPS ANT PORT	-11.892	0.797	13.047
TRANSOM PIVOT POINT STARBOARD	-39.727	3.366	2.385
TRANSOM PIVOT POINT PORT	-39.722	0.240	2.345

**NOAA SHIP FAIRWEATHER
POS MV COMPONENTS SPATIAL RELATIONSHIP SURVEY**



IMU Reference Points

**NOAA SHIP FAIRWEATHER
POS MV COMPONENTS SPATIAL RELATIONSHIP SURVEY**



POS GPS ANTENNAS

**NOAA SHIP FAIRWEATHER
POS MV COMPONENTS SPATIAL RELATIONSHIP SURVEY**



BOW CENTERLINE REFERENCE POINT

**NOAA SHIP FAIRWEATHER
POS MV COMPONENTS SPATIAL RELATIONSHIP SURVEY**



CENTERLINE REFERENCE POINT ON G DECK

**NOAA SHIP FAIRWEATHER
POS MV COMPONENTS SPATIAL RELATIONSHIP SURVEY**



CENTERLINE REFERENCE POINT ON RAIL AT G DECK

**NOAA SHIP FAIRWEATHER
POS MV COMPONENTS SPATIAL RELATIONSHIP SURVEY**



CENTERLINE STERN REFERENCE POINT

**NOAA SHIP FAIRWEATHER
POS MV COMPONENTS SPATIAL RELATIONSHIP SURVEY**



TRANSOM REFERENCE POINT ON PORT SIDE



TRANSOM REFERENCE POINT ON STARBOARD SIDE

**NOAA SHIP FAIRWEATHER
POS MV COMPONENTS SPATIAL RELATIONSHIP SURVEY**



8111 REFERENCE POINT



**NOAA SHIP FAIRWEATHER
POS MV COMPONENTS SPATIAL RELATIONSHIP SURVEY**



8160 REFERENCE POINT



**NOAA SHIP FAIRWEATHER
POS MV COMPONENTS SPATIAL RELATIONSHIP SURVEY**



USBL REFERENCE POINT



STABILITY TEST:

NOAA Ship FAIRWEATHER (16 Jul 2004)

SHIP AT TIME OF STABILITY TEST--CONDITION 0

		FROM HYDROSTATIC CURVES	FROM INDEPENDENT CALCULATION
Corrected displacement		tons	1638.79 tons
Mean virtual metacentric height obtained from plot of inclining moments versus tangents of angles of heel	$\frac{\text{moment}}{\text{displacement} \times \text{tangent}} = 5987.252 / 1638.790$	feet	3.65 feet
Correction for free surface	$= 374.0 / 1638.790$	feet	0.23 feet
Mean metacentric height G.M. =		feet	3.88 feet
Transverse metacenter above base line corresponding to draft at LCF (corrected for hog or sag)		feet	
Transverse metacenter above base line corrected for trim, and hog or sag		feet	
C.G. above base line		feet	16.37 feet (from figure)
			16.36 feet (from GHS)
Longitudinal metacenter above C.G.		feet	
Moment to alter trim 1 foot, (Long GM x Δ) / L		ft-tons	
Trim by stern		feet	
Trimming lever = (Trim x moment to trim) / displacement		feet	
Longitudinal center of buoyancy (LCB) from origin		feet	
C.G. from origin		feet	102.44 feet (from figure)
			102.42 feet (from GHS)

Period of complete roll _____ seconds

Apparent radius of gyration of vessel $\alpha = \frac{T GM}{1.108}$ _____ feet

Rolling constant $C = \frac{T GM}{B}$ _____

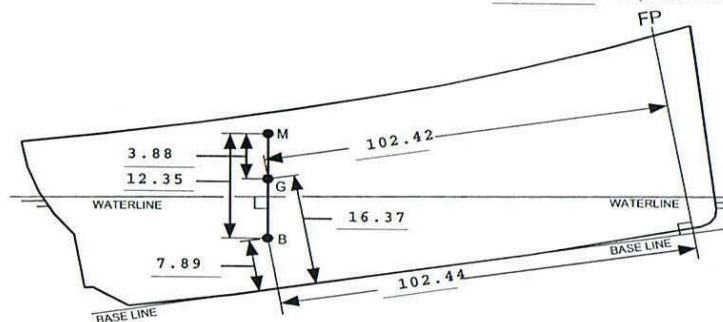

7/29/2004 8:05 AM

Definitions and Basis for Dimensions/Locations

Northings

Northings (Port - Starboard) are with reference to the IMU Foundation Plate centerline scribe.

Positive values are starboard of the IMU.

Negative values are port of the IMU.

Calculated values are in italics.

Eastings

Eastings (Stern to Bow) are with reference to the IMU Foundation Plate centerline scribe.

Positive values are forward of the IMU.

Negative values are aft of the IMU.

Calculated values are in italics.

Elevations

Elevations are with reference to the IMU Foundation Plate centerline scribe = 0 elevation.

Positive values are below the IMU (toward the keel).

Negative values are toward the topside.

Dimensions

All dimensions are in feet and decimal feet. All dimensions provided are "offsets" to IMU centerline.

Ship's Centerline Data

At project initiation, control was established to define the ship's centerline as a plane running from a point on the centerline of the keel at the stern through a point on the centerline of the keel near the bow, to a point on the bow splitting the bow chock.

IMU Referenced Data - Procedure

All data was originally referenced to the ship's geometry.

Following location of the IMU, data was transformed to the IMU as point of origin for

Northings, Eastings, and Elevation. All dimensions provided with reference to the IMU are "offsets."

Ship's Centerline - Control Measurements

(Prior to location of IMU and referencing of data to IMU as point of origin (0,0,0))

Defined by measurements at the keel centerline

	longitude	transverse	elevation
near the bow	1190.674	1000.000	135.8672
at the stern (point of origin)	1000.000	1000.000	100.0000
along the keel (approx 180' forward)	1180.121	1000.000	116.6810

Ship's Baseline

Defined by measurements on the keel

	longitude	transverse	elevation
at the stern (point of origin)	1000.000	1000.000	100.0000
and approx. 129' forward of stern	1129.120	999.985	100.0022

IMU Foundation Plate

	EASTING	NORTHING	ELEVATION
Horizontal alignment per scribed lines on IMU foundation plate		0.001 0.000	
Scribed lines - intersection/centerline of IMU plate	0.000	0.000	0.000
Elevation checks near four corners of IMU Foundation plate *			0.001
<i>* elevation check adjusted for target that created 10 mm offset =.03281 feet</i>			-0.001
			0.000
			-0.001

SUMMARY

- IMU foundation plate is level to within +/-0.001 feet.
- IMU foundation plate is located 12.856 feet above baseline established at the keel.
- IMU is parallel to ship's centerline to within +/- 0.001 feet.
Location of scribed centerline intersection is 6.122 feet port of ship's centerline.
- IMU foundation plate centerline is located 11.638' feet forward of bulkhead 52.

Granite Block

	EASTING	NORTHING	ELEVATION	
Horizontal alignment per scribed lines		1.584 1.583		
Scribed lines - intersection/centerline of granite block	-0.003	1.583		
Elevation checks near four corners of granite block <i>* elevation check adjusted for target that created 10 mm offset = 0.03281 feet</i>			-0.217 -0.217 -0.216 -0.215	Deviation from level -0.001 -0.001 0.001 0.001

SUMMARY

- Granite block is level to within +/-0.001 foot of average elevation = -0.21632 feet
- Granite block is parallel to ship's centerline to within 0.001 foot
Location is 4.54 feet to port of ship's centerline and 1.583 feet starboard of IMU.
- Granite block is aligned with IMU to within 0.003 feet longitudinally.

Array Acoustical Centers - Referenced to IMU

	<i>EASTING</i>	<i>NORTHING</i>	<i>ELEVATION</i>
PORT ARRAY (81-60)	25.149	1.619	14.956

Explanation of Calculations

Acoustic center is defined as the center of the transmitter array with the elevation = 83 mm below mounting face of array.

Easting

Center of array is defined by the foundation plate bolt centerlines (1/2 distance between bolts)

- 27.008 Forward edge of foundation as measured
- 0.104 Forward edge of foundation to centerline of forward bolt hole
- 1.755 Distance from bolt hole centerline to center of array

25.149 feet forward of IMU

Northing

Center of array is defined as the mid-point between the bolt holes on the foundation.

- 1.369 Port edge of foundation as measured
- + 0.078 Port edge of foundation to centerline of bolt hole - per Cascade General
- + 0.172 Distance from bolt hole centerline to array center

1.619 feet starboard of IMU

Elevation

Per Reson drawing 2148M011_001 the elevation is 83 mm below array mounting surface

- 14.679 Array foundation elevation as measured.
- 0.005 Isolation "shim" added between foundation and array
- 0.272 83 mm below array mounting surface to acoustical center

14.956 feet below IMU

Array Acoustical Centers - Referenced to IMU

	<i>EASTING</i>	<i>NORTHING</i>	<i>ELEVATION</i>
STARBOARD ARRAY (81-11)	27.072	9.41	15.042

Explanation of Calculations

Acoustic center is defined as midpoint of the transmitter array in the longitudinal and transverse axes. The elevation is defined as the center of the receiving array.

Easting

Center of array is defined as 0.235' aft of the forward bolt centerlines on transmitter array foundation

- 28.563 Forward edge of foundation fixture plate as measured (receiving plate forward edge)
- 27.349 Forward edge of transmitter array foundation as calculated
- 0.042 Forward edge of foundation to centerline of forward bolt hole - per design
- 0.235 Distance from bolt hole centerline to center of array - per design
- 27.072 feet forward of IMU

Northing

Center of array is defined as the mid-point between the bolt holes on the transmitter array foundation.

- 9.410 Centerline of array foundation as measured on scribe - aft section of fixture plate
- 9.410 feet starboard of IMU

Elevation

Elevation is 0.401 feet above receiver array mounting surface

- 16.085 Mounting foundation fixture plate as measured.
- 15.447 Receiver foundation elevation - as calculated
- + 0.005 Isolation "shim" added between foundation and array
- 0.410 Design distance from mounting surface of array to acoustic center
- 15.042 feet below IMU

Longitudinal Array Foundation - Port Side

	EASTING	NORTHING	ELEVATION	
Horizontal alignment <i>measured</i> at port edge of array foundation		1.369		
		1.369		
Forward edge of array foundation - <i>measured</i>	27.008			
Horizontal alignment - <i>calculated</i> to array centerline		1.619		
<i>Foundation edge is 0.25 feet port of array centerline</i>		1.619		
Elevation checks near four corners of array foundation				deviation from level (average)
			14.680	0.001
			14.681	0.002
			14.678	-0.001
			14.677	-0.002

SUMMARY

- Port longitudinal array foundation average elevation is 14.679 feet.
Variation in elevation is +0.002 to -0.002 feet.
- Port longitudinal array foundation is parallel to ship's centerline and 1.369 feet starboard of IMU.
Calculated array centerline is 1.619 feet starboard of IMU

Longitudinal Array Foundation - Starboard Side

	EASTING	NORTHING	ELEVATION	
Horizontal alignment <i>measured</i> on fixture plate scribe - <i>Design location is 3.292 feet starboard of ship centerline</i>		9.410 9.406		<i>deviation from parallel</i> 0.002 -0.002
Forward edge of array foundation fixture plate - <i>measured</i>	28.563			
Elevation checks near four corners of array foundation "fixture plate"			16.085 16.085 16.084 16.085	<i>deviation from average</i> 0.000 0.000 0.000 0.000
<i>Calculated locations of longitudinal and transverse array foundations</i>				
Forward edge				
Receiver (transverse)	28.563			
Transmitter (longitudinal)	27.349			
	<i>difference = 1.214</i>			
 NOTE: <i>On Transmitter array foundation - from forward edge to center of forward holes = 0.042'</i> <i>On Receiver array foundation distance from forward edge to center of forward holes = 0.076'</i>				
 <i>Calculated elevation of longitudinal and transverse array foundations</i>				
Receiver/Transverse Foundation			15.446	
Transmitter/Longitudinal Foundation			15.709	
	<i>difference = 0.263</i>			

SUMMARY

- Starboard longitudinal array foundation (measured at fixture plate) average elevation is 16.085 feet. Deviation from level (average elevation) is less than 0.001 feet.
- Starboard longitudinal array foundation averages 9.408 feet starboard of IMU. Variation from parallel is from -0.002 feet to +0.002 feet from average.
- Starboard longitudinal array foundation forward edge is 28.563 feet forward of IMU.

Transverse Array Foundation - Port Side

	EASTING	NORTHING	ELEVATION	
Forward Edge - Transverse array foundation - <i>measured</i>	28.343			
	28.338			
Port edge - Transverse array - <i>measured</i>		-0.181		
Centerline of array - <i>calculated</i>				
Foundation forward edge minus 0.25 feet to array centerline	28.093			
	28.088			
Port edge of foundation plus 1.806 feet to calculated array centerline		1.624		
Elevation checks near four corners of array foundation			14.679	deviation from level
			14.675	0.002
0.861 feet below baseline with 0.965 foot offset = 98.180 feet average elevation			14.675	-0.001
			14.677	-0.001
				0.001

SUMMARY

- Transverse array foundation average measured elevation is 14.677 feet below IMU (0.006 feet above design location).
Deviation from level (average elevation) is 0.003 to -0.001 feet
- Transverse array foundation centerline (calculated) averages 28.090 feet forward of IMU.
Variation from parallel to ship's centerline is from -0.003 to 0.003 feet (from average).
- Transverse array centerline is calculated to be 1.624 feet starboard of IMU.

Transverse Array Foundation - Starboard Side

NOTE: Direct Measurements were not taken to the transverse array because a single "fixture plate" covered both transmitter and receiver foundations. The data provided here is primarily "calculated".

	EASTING	NORTHING	ELEVATION
Forward edge - as measured on fixture plate			
Receiver - (transverse)	28.563		
as measured			
Transmitter (longitudinal)	27.349		
<i>difference = 1.214</i>			
 NOTE: On Transmitter array foundation - from forward edge to center of forward holes = 0.042' On Receiver array foundation distance from forward edge to center of forward holes = 0.076'			
Horizontal Alignment		9.406	
centerline scribe on fixture plate			
as measured - forward portion of plate			
(near receiver array)			
Average of measurements on fixture plate		9.408	
 <i>Elevation of longitudinal and transverse array foundations</i>			
Receiver/Transducer Transverse Foundation			15.446
Transmitter/Longitudinal Foundation			15.709
<i>difference = 0.263</i>			

Based on measured elevations averaging 16.085 feet across fixture plate

SUMMARY

- Transverse array foundation is calculated to be 15.446 feet below IMU - calculated from measured elevation of 16.085 feet. Deviation in elevation measurements across the array fixture plate is less than 0.001 feet
- Transverse array foundation forward edge (measured) is 28.563 feet forward of IMU.
- Transverse array centerline is measured to be 9.406 feet starboard of IMU.

Variation from parallel of the fixture plate across entire starboard array is ± 0.002 feet (from average).

Antennae

	<i>EASTING</i>	<i>NORTHING</i>	<i>ELEVATION</i>
Stbd POS MV Antenna -Location	-35.866	12.925	-38.209
Port POS MV Antenna - Location	-35.739	-0.409	-38.283
Foundation Plate Stack Antenna Alignment		7.677	
Foundation Plate Stack Antenna Alignment		7.677	
Port GYRO Foundation Plate Alignment		2.411	
Port GYRO Foundation Plate Alignment		2.411	
Stbd GYRO Foundation Plate Alignment		3.866	
Stbd GYRO Foundation Plate Alignment		3.867	

SUMMARY

- Foundation plate stack antenna alignment is parallel to ship's centerline.
- Port GYRO Foundation Plate is aligned parallel to ship's centerline.
- Starboard GYRO Foundation Plate is aligned parallel to ship's centerline.

FAIRWEATHER

Multibeam Echosounder Calibration

S220 7111

Vessel

4/20/2012	111	Shilshole Bay
Date	Dn	Local Area
2000-2400 Francksen, Bowker; 0000-0400 Faulkes, Robinson		
Calibrating Hydrographer(s)		
7111	Hull Mounted	~5/1/2009 TPU
MBES System	MBES System Location	Date of most recent EED/Factory Check
2009003		
Sonar Serial Number		Processing Unit Serial Number
Fixed Hull Mount		9/23/2003 and 2/15/2009
Sonar Mounting Configuration		Date of current offset measurement/verification
Applanix POS/MV S/N:3627 IMU S/N:292		4/19/2012
Description of Positioning System		Date of most recent positioning system calibration

Acquisition Log

4/20/2012	111	Shilshole Bay	cloudy, choppy, rainy
Date	Dn	Local Area	Wx

Bottom Type	Approximate Water Depth
-------------	-------------------------

2000-2400 Francksen, Bowker; 0000-0400 Faulkes, Robinson

Personnel on board

Patch test was not completed because of a barge on the bouy.

Comments

2012_111_S220, 2012_111_S220_ERDDMa

POSMV Filename(s)

SV Cast #1 filename	UTC Time	Lat	Lon	Depth	Ext. Depth
	~2200				
BOT_0002	0849	47/43/46.55N	122/29/39.42W		
SV Cast #2 filename	UTC Time	Lat	Lon	Depth	Ext. Depth
SV Cast #3 filename	UTC Time	Lat	Lon	Depth	Ext. Depth

view parallel to track, one line with induced roll (outerbeam) or same lines bounded slope (nadir)
[same direction, different speed]

NAV TIME LATENCY

SV Cast #	XTF Line Filename	Heading	Speed (kts)	Remarks
	1110652	271	4, 6	
	1110714	100	6, 4	
	1110743	274	8.0	
	1110757	100	8.0	
	1110814	271	10.0	
	1110827	098	10.0	

PITCH view parallel to track, same line (at nadir) [opposite direction, same speed]

SV Cast #	XTF Line Filename	Heading	Speed (kts)	Remarks
	1110652	271	4, 6	150/45 rpm
	1110714	100	6, 4	160/50 rpm
	1110743	274	8.0	
	1110757	100	8.0	
	1110814	271	10.0	
	1110827	098	10.0	
	1111722	230	4.0	
	1111750	230	5.3	

HEADING/YAW view parallel to track, offset lines (outerbeams) [opposite direction, same speed]

SV Cast #	XTF Line Filename	Heading	Speed (kts)	Remarks
	1111359	050	4.0	logged through turn
	1111411	230	4.0	
	1111426	050	4.0	
	1111644	050	4.0	
	1111655	230	4.0	
	1111711	050	4.0	
		050	4.0	

ROLL view across track, same line [opposite direction, same speed]

SV Cast #	XTF Line Filename	Heading	Speed (kts)	Remarks
	1110339	050	4.0	
	1110353	230	4.8	40 m off line (use not recommended)
	1110403	050	5.0	
	1110414	230	6.0	15 m off line
	1110433	230	4.8	

stopped for 20 minutes for barge to locate

Processing Log

4/24/2012 | 115 | Beduhn

Date | Dn | Personnel

- Data converted --> HDCS_Data in CARIS
- TrueHeave applied all 7 files
- SVP applied NIDWT 4hrs
- Tide applied preliminary

Zone file N395FA2010CORP.zdf

Lines merged

Data cleaned to remove gross fliers

Compute correctors in this order

1. Precise Timing 2. Pitch bias 3. Heading bias 4. Roll bias

Do not enter/apply correctors until all evaluations are complete and analyzed.

PATCH TEST RESULTS/CORRECTORS

Evaluators	Latency (sec)	Pitch (deg)	Roll (deg)	Yaw (deg)
Zacharias	0.00		-0.01	-0.43
Faulks	0.00	-0.28	-0.03	
Raymond	0.00		-0.03	-0.31
Beduhn	0.00	-0.40	-0.01	-0.38
Averages	0.00	-0.34	-0.02	-0.38
Standard Deviation	0.00	0.08	0.01	0.06
FINAL VALUES	0.00	-0.34	-0.02	-0.38

Final Values based on

Resulting HVF File Name

MRU Align StdDev gyro 0.06 Value from standard deviation of Heading offset values
 MRU Align StdDev Roll/Pitch 0.05 Value from averaged standard deviations of pitch and roll offset values

NARRATIVE

- HVF Hydrographic Vessel File created or updated with current offsets

Name: Tami Beduhn

Date: 4/25/2012

FAIRWEATHER

Multibeam Echosounder Calibration

S220 8160

Vessel

6/13/2011 | 164 | Kodiak, Marmot Bay
Date Dn Local Area

Moehl, Bravo
Calibrating Hydrographer(s)

RESON 8160 | Hull Mount S220 | 2004
MBES System MBES System Location Date of most recent EED/Factory Check

Unknown | 35385
Sonar Serial Number Processing Unit Serial Number

Hull Mount |
Sonar Mounting Configuration Date of current offset measurement/verification

Applanix POS/MV v.4 |
Description of Positioning System Date of most recent positioning system calibration

Acquisition Log

6/13/2011 | 164 | Marmot Bay, Kodiak Island | Cldy, Seas <1ft
Date Dn Local Area Wx

| 20-100m
Bottom Type Approximate Water Depth

Moehl, Bravo
Personnel on board

Comments

2011_164_S220.000
TrueHeave filename

| | | | |

| | | | |
SV Cast #2 filename UTC Time Lat Lon Depth

NOAA POS/MV Calibration Report

Fill out all fields! See previous years as an example.

Yellow areas require screen grabs!

Ship: FAIRWEATHER

Vessel: S220

Date: 4/19/2012

Dn: 111

Personnel: Beduhn, Arnold, Robinson, Bowker

PCS Serial # 3627

IMU Serial # 292

IP Address: 129.100.1.231

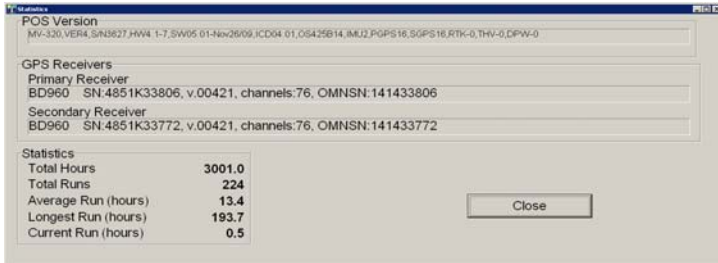

POS Version (Use Menu View > Statistics)

GPS Receivers
Primary Receiver Serial #: 1440904133
Secondary Receiver Serial #: 31180200

2012_111_S220_GAMS.000

POSMV filename(s)

Calibration area

Location: Oak Bay, Puget Sound

Approximate Position:

Lat	47	59	48.17N
Lon	122	40	31.98W

DGPS Beacon Station: Robinson, Pt
Frequency: 323

DGPS Receiver Serial#: _____

Satellite Constellation

(Use View> GPS Data)

Primary GPS

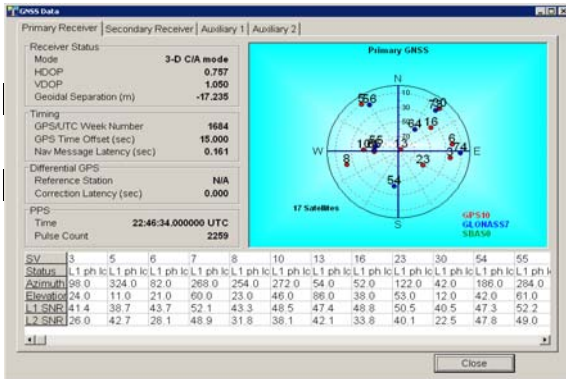

Secondary GPS

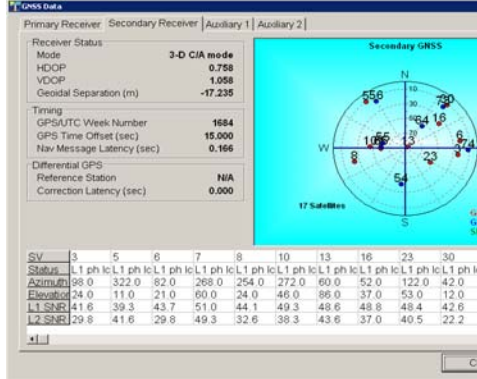

PDOP 1.826-2.514

(Use View> GAMS Solution)

POS/MV Configuration

Settings

Two Antenna Separation (m)	1.995
Heading Calibration Threshold (deg)	0.500
Heading Correction (deg)	0.000
Baseline Vector	
X Component (m)	0.000
Y Component (m)	0.000
Z Component (m)	0.000

POS/MV Calibration

Calibration Procedure:

(Refer to POS MV V4 Installation and Operation Guide, 4-25)

Start time: 2245

End time: 2316

Heading accuracy achieved for calibration: 0.469

Calibration Results:

Gams Parameter Setup

(Use Settings > Installation > GAMS Intallation)

Two Antenna Separation (m)	1.997
Heading Calibration Threshold (deg)	0.500
Heading Correction (deg)	0.000
Baseline Vector	
X Component (m)	-0.007
Y Component (m)	1.997
Z Component (m)	0.012

Save POS Settings on PC

(Use File > Store POS Settings on PC)

File Name: 2012_111_S220_GAMS.000

D:\HYPACK 2012\Projects\HSRR2012\Raw\Positioning

General Notes:

The POS/MV uses a Right-Hand Orthogonal Reference System

The right-hand orthogonal system defines the following:

- The x-axis is in the fore-aft direction in the appropriate reference frame.
- The y-axis is perpendicular to the x-axis and points towards the right (starboard) side in the appropriate reference frame.
- The z-axis points downwards in the appropriate reference frame.

The POS/MV uses a Tate-Bryant Rotation Sequence

Apply the rotation in the following order to bring the two frames of reference into complete alignment:

- a) Heading rotation - apply a right-hand screw rotation θ_z about the z-axis to align one frame with the other.
- b) Pitch rotation - apply a right-hand screw rotation θ_y about the once-rotated y-axis to align one frame with the other.
- c) Roll rotation - apply a right-hand screw rotation θ_x about the twice-rotated x-axis to align one frame with the other.

SETTINGS

Input/Output Ports (Use Settings > Input/Output Ports)

COM1

Input/Output Ports Set-up

COM1 | COM2 | COM3 | COM4 | COM5

Baud Rate: 9600

Parity: None Even Odd

Data Bits: 7 Bits 8 Bits

Stop Bits: 1 Bit 2 Bits

Flow Control: None Hardware XON/XOFF

Output Select: NMEA

NMEA Output:

- \$INGST
- \$INGGA
- \$INHDT
- \$INZDA
- \$INVTG
- \$PASHR

Update Rate: 1 Hz

Talker ID: IN

Roll Positive Sense: Port Up Starboard Up

Pitch Positive Sense: Bow Up Stern Up

Heave Positive Sense: Heave Up Heave Down

Input Select: None

Close Apply

COM2

Input/Output Ports Set-up

COM1 | COM2 | COM3 | COM4 | COM5

Baud Rate: 19200

Parity: None Even Odd

Data Bits: 7 Bits 8 Bits

Stop Bits: 1 Bit 2 Bits

Flow Control: None Hardware XON/XOFF

Output Select: Binary

Binary Output:

Update Rate: 25 Hz

Frame: Sensor 1 Sensor 2

Formula Select: SIMRAD 3000 (TSS)

Roll Positive Sense: Port Up Starboard Up

Pitch Positive Sense: Bow Up Stern Up

Heave Positive Sense: Heave Up Heave Down

Input Select: None

Close Apply

COM3

Input/Output Ports Set-up

COM1 | COM2 | **COM3** | COM4 | COM5

Baud Rate: 9600

Parity: None Even Odd

Data Bits: 7 Bits 8 Bits

Stop Bits: 1 Bit 2 Bits

Flow Control: None Hardware XON/XOFF

Output Select: None

Input Select: Base GPS Input: Base 1 GPS

Input Type: RTCM 1 or 9 Datum: WGS84

Line: Serial Modem Modem Settings

Close Apply

SETTINGS Continued

Heave Filter

Heave Filter

Heave Bandwidth (sec): 12.000

Damping Ratio: 0.707

Ok Close Apply

Events

Events

Event 1: Positive Edge Trigger Negative Edge Trigger

Event 2: Positive Edge Trigger Negative Edge Trigger

Ok Close Apply

INSTALLATION

(Use Settings > Installation)

Lever Arms and Mounting Angles

(Use Settings > Installation > Lever Arms and Offsets)

Lever Arms & Mounting Angles

Lever Arms & Mounting Angles | Sensor Mounting | Tags, Multipath & AutoStart

Ref. to IMU Lever Arm: X (m) 0.000, Y (m) 0.000, Z (m) 0.000

IMU Frame w.r.t. Ref. Frame: X (deg) 0.000, Y (deg) 0.000, Z (deg) 0.000

Ref. to Primary GPS Lever Arm: X (m) -11.892, Y (m) 0.797, Z (m) -13.085

Ref. to Vessel Lever Arm: X (m) 0.000, Y (m) 0.000, Z (m) 0.000

Notes:
1. Ref. = Reference
2. w.r.t. = With Respect To
3. Reference Frame and Vessel Frame are co-aligned

Ref. to Centre of Rotation Lever Arm: X (m) 0.000, Y (m) 0.000, Z (m) 0.000

Ok Close Apply View

In Navigation Mode, to change parameters go to Standby Mode!

Tags, Multipath and Auto Start

(Use Settings > Installation > Tags, Multipath and Auto Start)

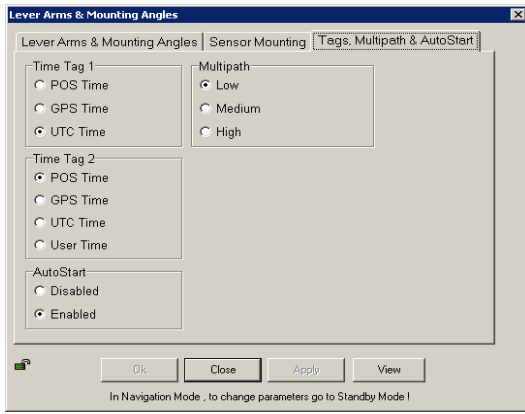

Sensor Mounting

(Use Settings > Installation > Sensor Mounting)

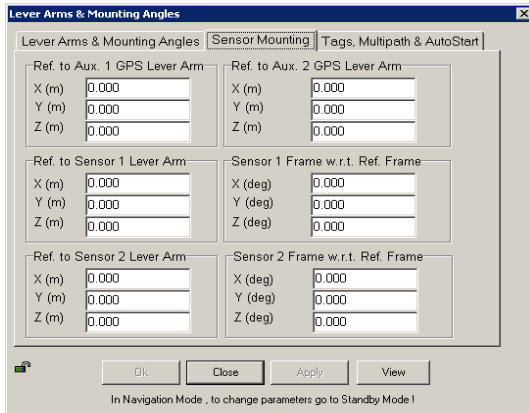

User Parameter Accuracy

(Use Settings > Installation > User Accuracy)

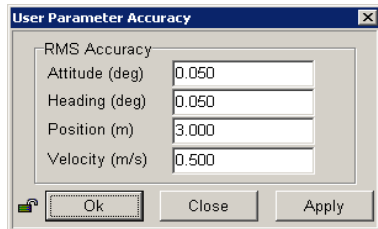

Frame Control

(Use Tools > Config)

Can't Open

<input type="checkbox"/>	User Frame	Primary GPS Measurement	<input type="checkbox"/>
<input type="checkbox"/>	IMU Frame	Auxiliary GPS Measurement	<input type="checkbox"/>
<input type="checkbox"/>	Use GAMS enabled		

GPS Receiver Configuration

(Use Settings> Installation> GPS Receiver Configuration)

Primary GPS Receiver

The dialog box is titled "Gps Receiver Configuration" and has two tabs: "Primary GPS Receiver" (selected) and "Secondary GPS Receiver".

Primary GPS

- GPS Output Rate: 1 Hz

Auto Configuration

- Enabled
- Disabled

GPS 1 Port

- Baud Rate: 9600

Parity

- None
- Even
- Odd

Data Bits

- 7 Bits
- 8 Bits

Stop Bits

- 1 Bit
- 2 Bits

Buttons: Ok, Close, Apply

Secondary GPS Receiver

The dialog box is titled "Gps Receiver Configuration" and has two tabs: "Primary GPS Receiver" and "Secondary GPS Receiver" (selected).

Secondary GPS

- GPS Output Rate: 1 Hz

Auto Configuration

- Enabled
- Disabled

GPS 2 Port

- Baud Rate: 9600

Parity

- None
- Even
- Odd

Data Bits

- 7 Bits
- 8 Bits

Stop Bits

- 1 Bit
- 2 Bits

Buttons: Ok, Close, Apply

Post Processing of GAMS Calibration Processing Log

		ENS Witmer
Date	Dn	Personnel
<input checked="" type="checkbox"/>	POS Pac Processing	Allow decimeter level freedom when processing
<input checked="" type="checkbox"/>		Reprocess using new values, but restrict to 10 cm of freedom
<input checked="" type="checkbox"/>		Reprocess using new values, again use 10 cm of freedom
<input checked="" type="checkbox"/>		Continue iterating until values no longer change
	Final Antena Seperation/ Lever Arms Determined <input checked="" type="checkbox"/>	See FOO/CST with values
	New Values entered in POS View? <input type="checkbox"/>	Values

Processing Log

6/13/2011 | 164 | Moehl, Bravo
 Date Dn Personnel

Data converted --> HDCS_Data in CARIS

TrueHeave applied 2011_164_S220_Patch.000

SVP applied BOT0000.svp NIDWT 3
 Can't process the cast files with the new configs

Tide applied P136FA2011CORP.zdf

Zone file Kodiak project

Lines merged

Data cleaned to remove gross fliers

Compute correctors in this order

1. Precise Timing

2. Pitch bias

3. Heading bias

4. Roll bias

Do not enter/apply correctors until all evaluations are complete and analyzed.

PATCH TEST RESULTS/CORRECTORS

Evaluators	Latency (sec)	Pitch (deg)	Roll (deg)	Yaw (deg)
Moehl	0.00	-0.19	-0.12 *	-0.04
Eisenberg	0.00	-0.30	-0.05	-0.10
Faulkes	0.00	-0.63	-0.57 *	-0.30
Francksen	0.00	0.11	-0.10	-0.74
Froelich	0.00	-0.52	-0.04	-0.44
Morgan	0.00	-0.25	-0.02	-0.20
Averages				
	0.00	-0.30	-0.05	-0.30
Standard Deviation				
	0.00	0.26	0.21	0.26
FINAL VALUES				
	0.00	-0.30	-0.05	-0.30

Final Values based on Averages for Pitch and Yaw; Average with two values removed for Roll*.

Resulting HVF File Name FA_S220_Rsn8160_5to750_2011.hvf

MRU Align StdDev gyro 0.26 Value from standard deviation of Heading offset values
 MRU Align StdDev Roll/Pitch 0.23 Value from averaged standard deviations of pitch and roll offset values

NARRATIVE

*Value for Roll did not use the outlier nor the -0.12 value to determine patch value for use in the hvf, though all the values for Roll were retained for the Standard Deviation calculation.

HVF Hydrographic Vessel File created or updated with current offsets

Name: CST Morgan

Date: 6/23/2011

ERDDM Acquisition Log

S220 8160

Vessel

5/10/2012	131	Port Madison	clear and calm
Date	Dn	Local Area	Wx

Zacharias
Personnel

some currents (east direction required a little more engine order)
Comments

Robinson Point, WA - 323 kHz (200 BPS)
Tidal Cycle Notes USCG DGPS Beacon Used

2012_131_S220_ERDDM.000
POSMV filename(s)

POS File	Azmuth	Vessel Speed	RPM	Start and End Time
REST	drifting	~1.5	---	1049 -> 1054
	276	~4.5	140/40	1059 -> 1104
	094	~4.5	140/50	1119 -> 1125
REST	drifting	~.5-1.5	---	1125 -> 1131
	270	~6.5	160/50	1137 -> 1142
	090	~6.0	160/60	1150 -> 1156
REST	drifting	~0.5-1.5	---	1156 -> 1201
	270	~8.5	175/60	1204 -> 1209
	090	~8.0 (9.0tw)	175/70	1216 -> 1224
REST	drifting	~.1-1.0	---	1225 -> 1231
	270	~10.5	180/75	1233 -> 1238
	090	~9.5	180/80	1245 -> 1251
REST	drifting	~2	---	1251 -> 1258

Processing Log

5/13/2012		ENS Witmer
Date	Dn	Personnel

- POS Files Processed in POS Pac **Smartbase**
Smartbase or Singlebase? Station used.
- SBET Processed in Pydro Using the ERDDM Tool
- Graph and Table Values compared with previous year
- Documentaion Complete in DAPR Appendix
- See OPS/CST for updating HVF with new values

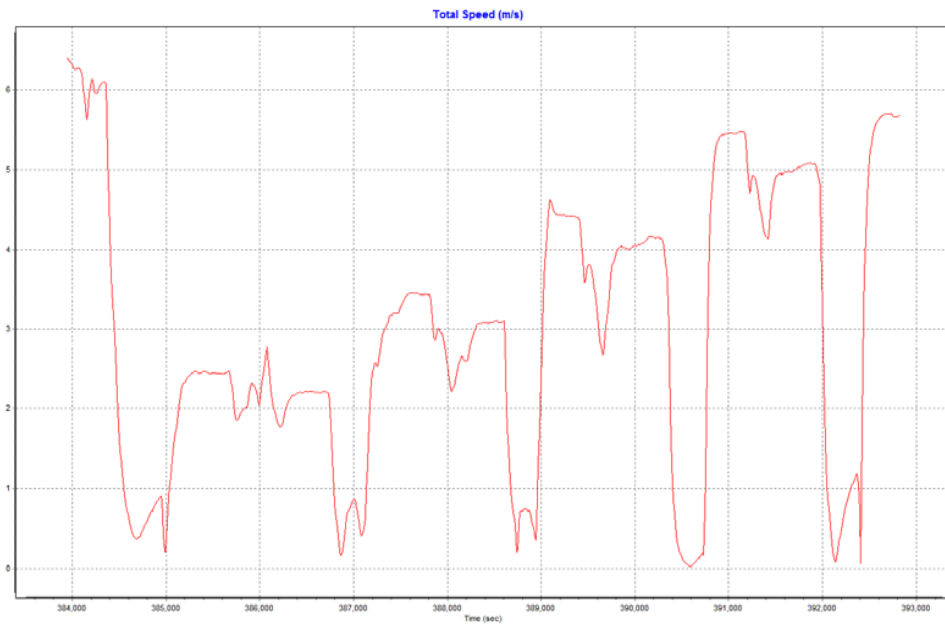
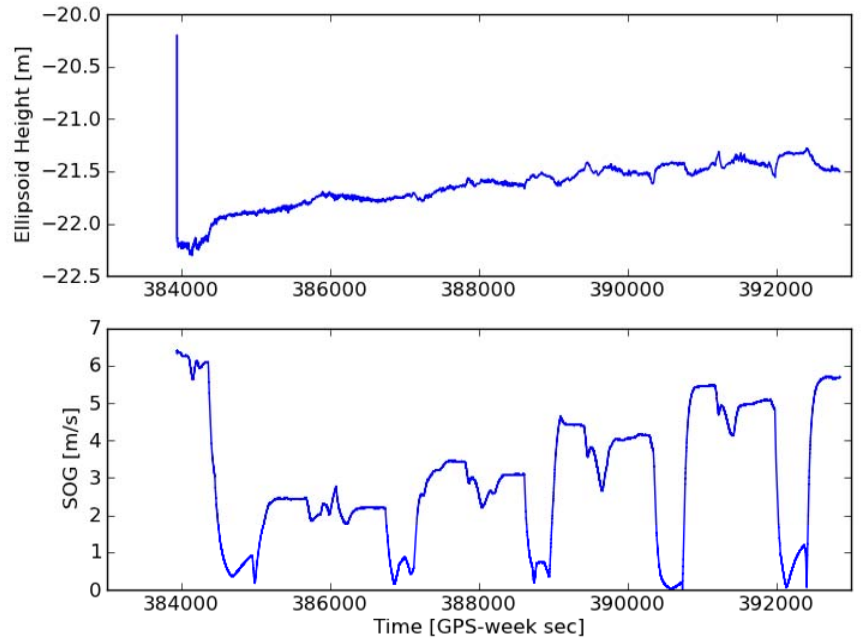
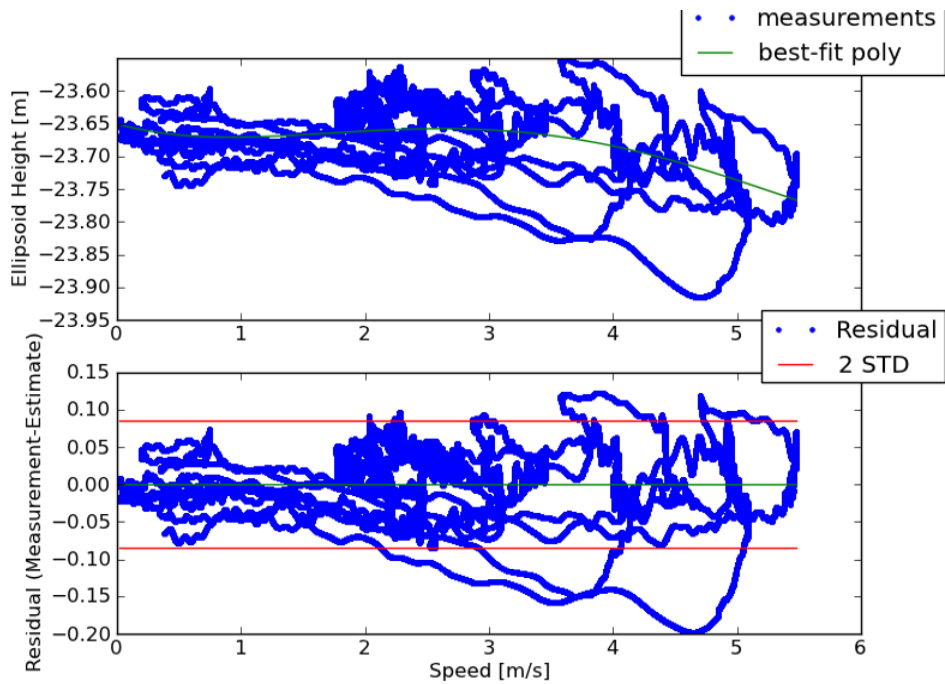

$$-0.000745 \cdot X^4 + 0.0106 \cdot X^3 - 0.0412 \cdot X^2 + 0.0513 \cdot X$$

Speed [m/s]	Delta Draft [m]
0.00	0.00
0.50	0.02
1.00	0.02
1.50	0.02
2.00	0.01
2.50	0.01
3.00	0.01
3.50	0.02
4.00	0.03
4.50	0.06
5.00	0.09
5.50	0.12

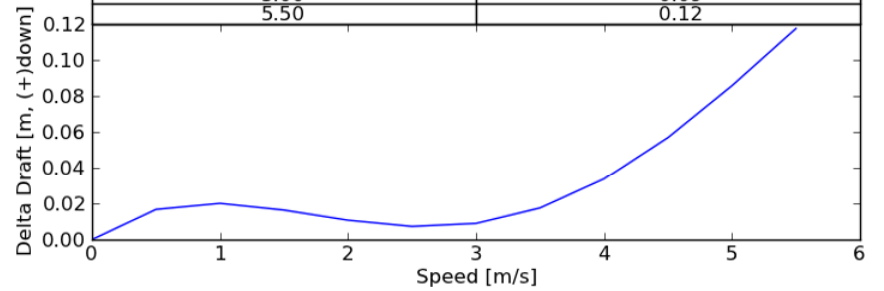

Hypack Coordinate System

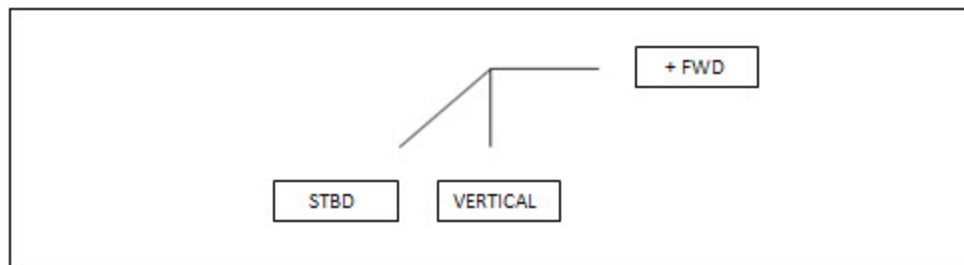
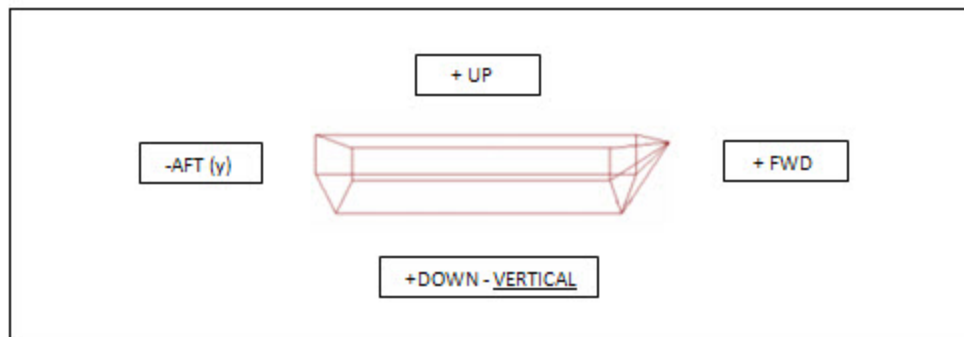
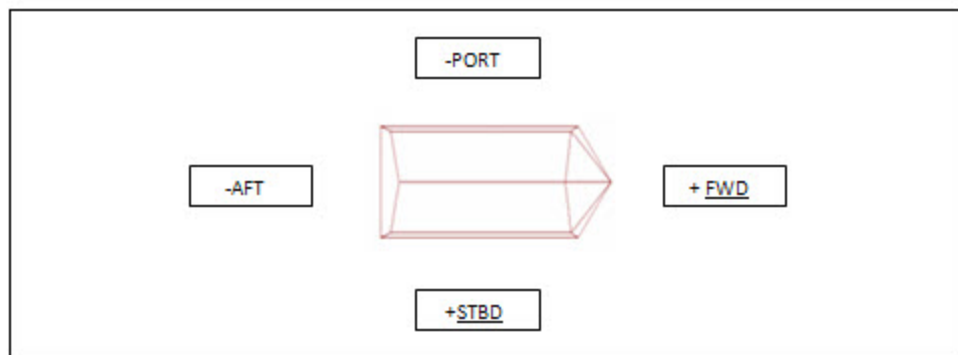

Top Center of IMU is origin of Hypack Coordinate System

NGS/ RESON Coordinate System

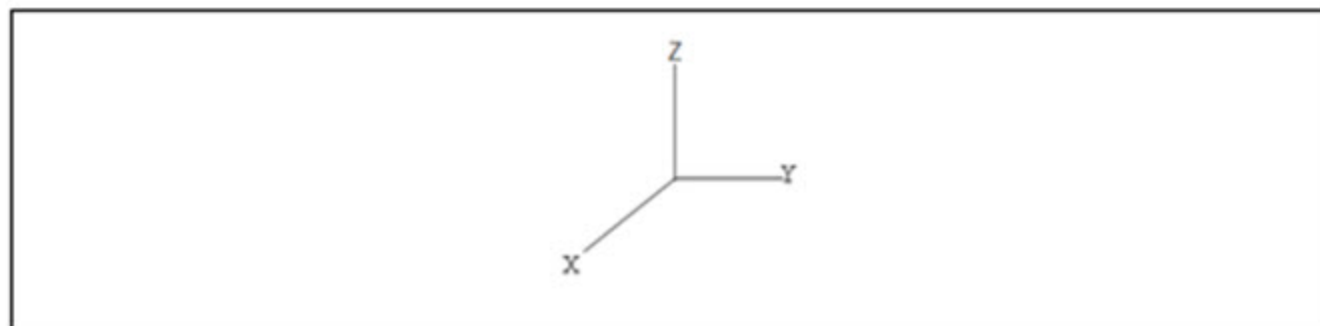
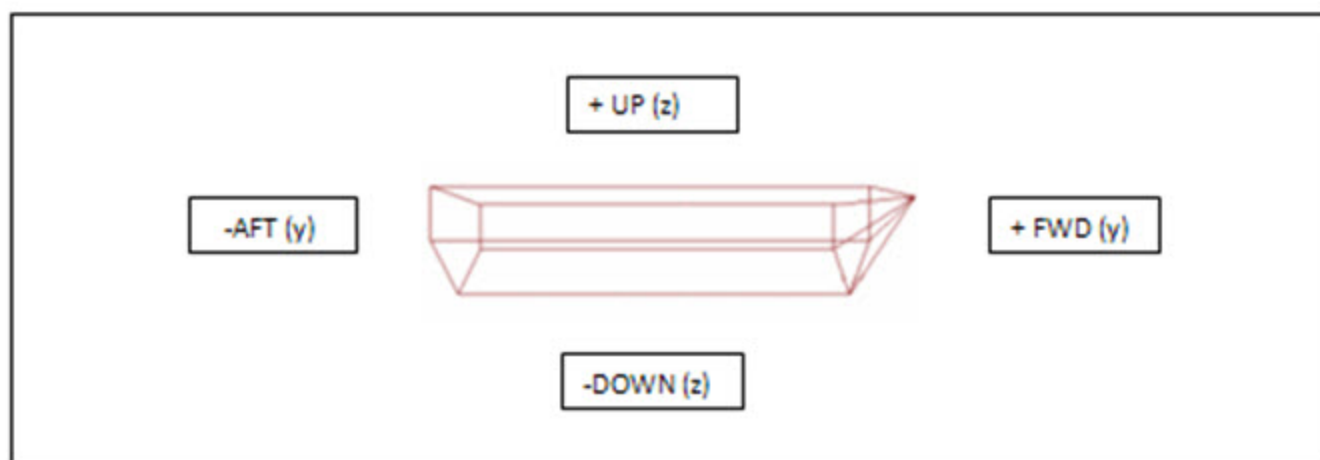
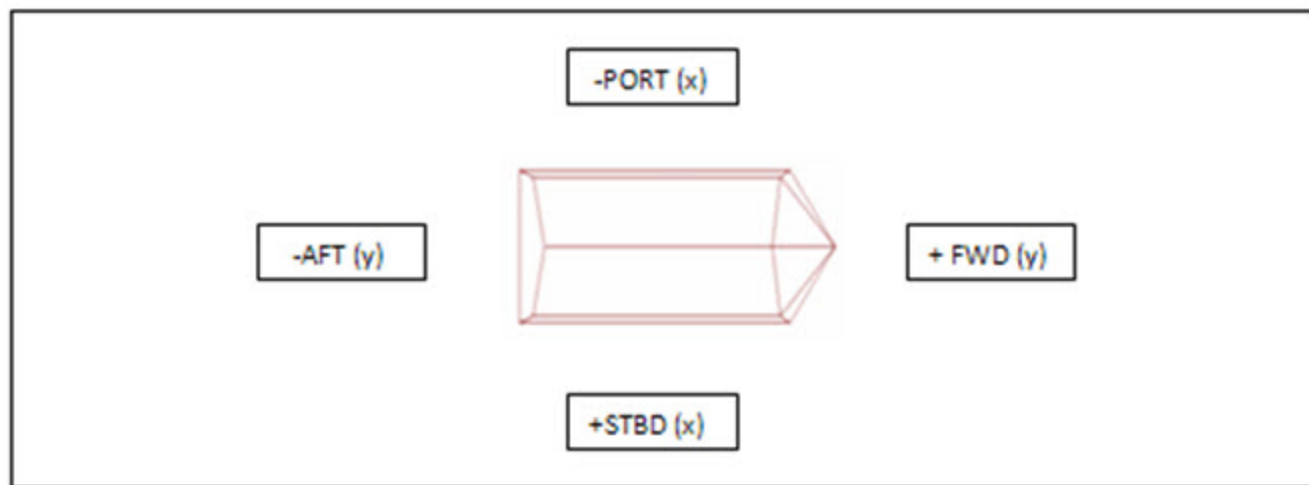

POS/MV Coordinate System

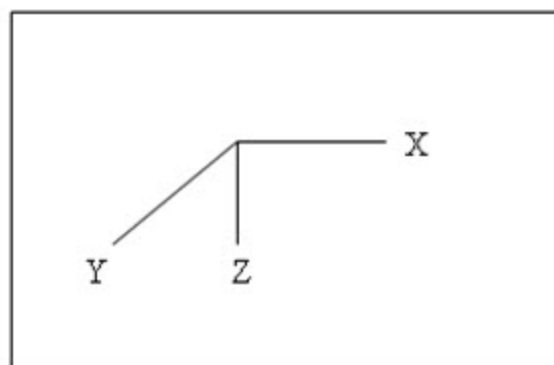
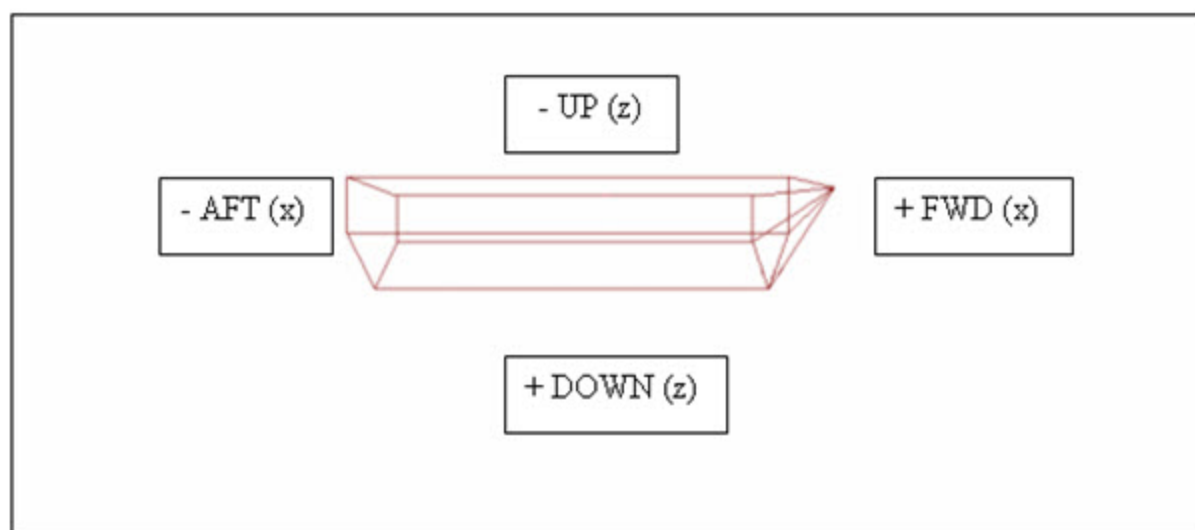
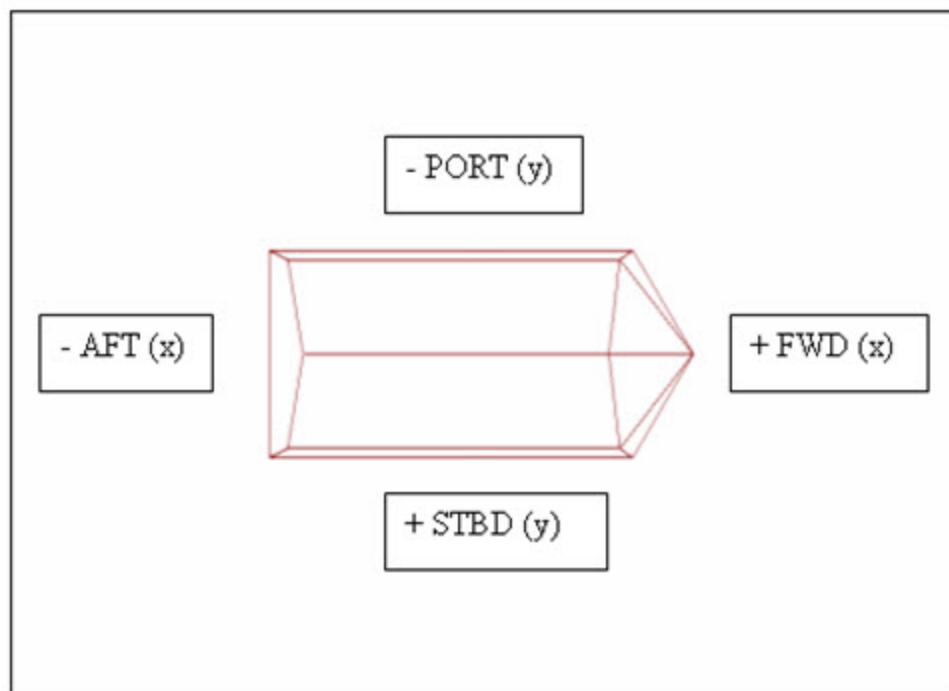

Top Center of IMU is origin of POS/MV Coordinate System

WESTLAKE Coordinate System

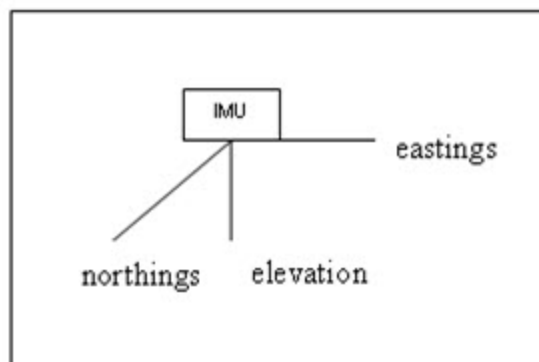
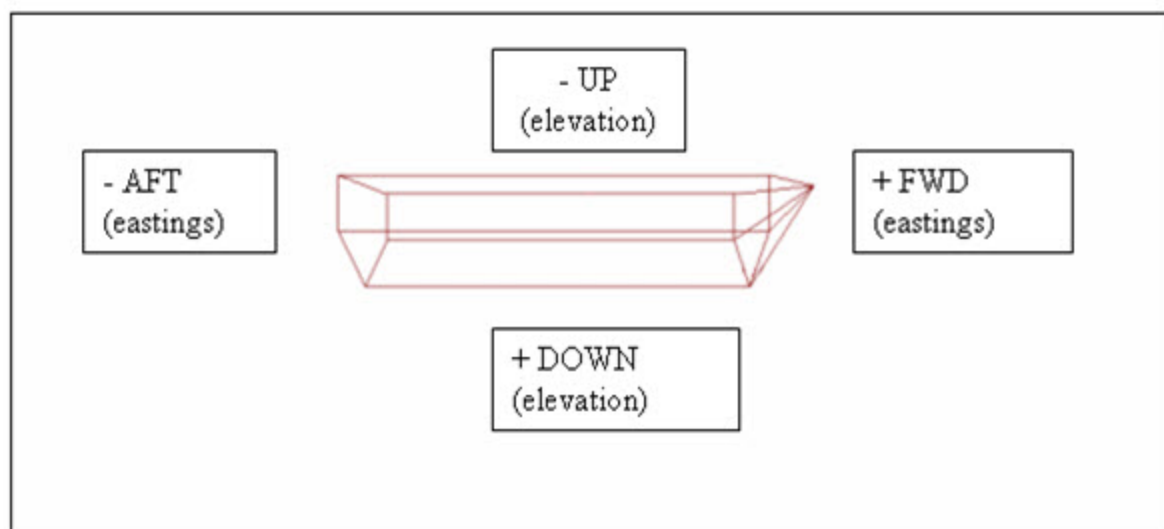
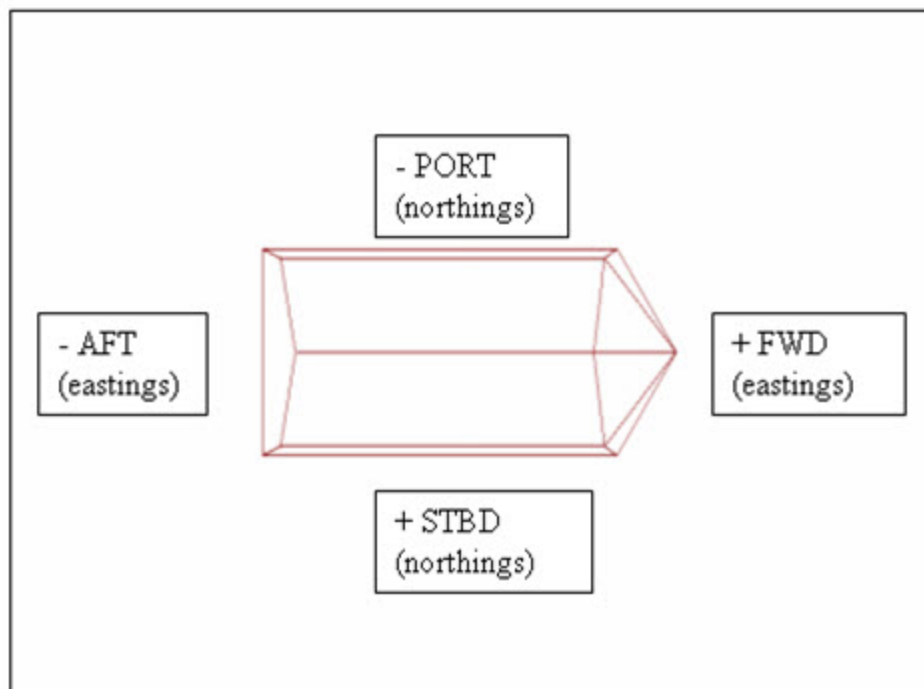

Bottom Center of IMU is origin of Westlake Coordinate System

Appendix III

Total Propagated Uncertainty (TPU)

Fairweather TPU Values

	FAIRWEATHER SURVEY		Appendix III	Process Owner Survey
	Documents Title FA_TPU_Values_2012	Last update October 1, 2012	Version 2012	Effective Date April 1, 2012

Offsets					
	Vessel	FAIRWEATHER-S220	FAIRWEATHER-S220	2805	2808
	Sonar System	Reson 7111	Reson 8160	Reson 7125	Reson 7125
	Frequency			200kHz 400kHz	200kHz 400kHz
	Positioning System	POS/MV Model 320 V4	POS/MV Model 320 V4	POS/MV Model 320 V4	POS/MV Model 320 V4
Offsets	MRU to Trans X	2.868	0.493	0.004	0.004
	MRU to Trans Y	8.252	7.665	0.245	0.250
	MRU to Trans Z	4.752	4.726	0.482	0.477
	Nav to Trans X	2.071	-0.304	0.686	0.685
	Nav to Trans Y	20.144	19.557	1.051	1.086
	Nav to Trans Z	17.821	17.794	3.656	3.637
	Trans Roll	0.00	0.00	0.000	0.000

Standard Deviation					
	Vessel	FAIRWEATHER-S220	FAIRWEATHER-S220	2805	2808
	Sonar System	Reson 7111	Reson 8160	Reson 7125	Reson 7125
	Frequency			200kHz 400kHz	200kHz 400kHz
	Positioning System	POS/MV Model 320 V4	POS/MV Model 320 V4	POS/MV Model 320 V4	POS/MV Model 320 V4
Motion Sensor	Motion Gyro (deg)	0.02	0.02	0.04	0.04
	Heave% Amp	5	5	5	5
	Heave (m)	0.05	0.05	0.05	0.05
	Roll (deg)	0.02	0.02	0.02	0.02
	Pitch (deg)	0.02	0.02	0.02	0.02
	Position Nav (m)	0.5*	0.5	0.5	0.5
	Vessel Speed (m/s)	0.03	0.03	0.03	0.03
Latency	Timing Trans (s)	0.005	0.005	0.005	0.005
	Nav Timing (s)	0.005	0.005	0.005	0.005
	Gyro Timing (s)	0.005	0.005	0.005	0.005
	Heave Timing (s)	0.005	0.005	0.005	0.005
	Pitch Timing (s)	0.005	0.005	0.005	0.005
	Roll Timing (s)	0.005	0.005	0.005	0.005
Vessel Offsets	Offset X (m)	0.007	0.007	0.006	0.006
	Offset Y (m)	0.007	0.007	0.006	0.006
	Offset Z (m)	0.008	0.008	0.006	0.006
Waterline	Loading	0.128	0.128	0.018	0.032
	Draft (m)	0.128	0.128	0.019	0.032
	DeltaDraft (m)	0.10	0.10	0.10	0.075
MRU Alignment	MRU alignStdev gyro	0.06	0.26	0.27 0.10	0.10 0.02
	MRU align roll/pitch	0.05	0.23	0.12 0.07	0.06 0.03
Tides	Tide Meas (m)	0.01	0.01	0.01	0.01
	Tide Zoning (m)	Project Dependent	Project Dependent	Project Dependent	Project Dependent
Sound Velocity	SV Meas (m/s)	0.5	0.5	2.0	2.0
	Surface SV (m/s)	0.5	0.5	0.5	0.5

Vessel Configuration File		Status
Compute TPE Dialog Box		Finalized
		Finalized
		Finalized
		Finalized
		Finalized
		Finalized
		Finalized
		Finalized
		Finalized
		Finalized
		Finalized
		Finalized
		Finalized
		Finalized
		Finalized
		Finalized
	Project Dependent**	Default=0.2, Project Dependent**
	Defaults, Project Dependent**	Defaults, Project Dependent**

*Position Nav adjusted in the HVF to 5m when acquiring in Coarse Acquisition mode, additional information will be submitted in the DAPR and/or the DR.
 **Default values listed, descriptive report will list actual values applied if supplied with Project Instructions or calculated with the Sound speed estimator.
 ^MRU values may change if new patch test values are used.