

W00156

NOAA FORM 76-35A

U.S. DEPARTMENT OF COMMERCE
NATIONAL OCEANIC AND ATMOSPHERIC ADMINISTRATION
NATIONAL OCEAN SURVEY

DESCRIPTIVE REPORT

Type of Survey **Hydrographic Survey**
Field No. NOAA R/V AHI
Registry No. **W00156**

LOCALITY

State **Commonwealth of Northern Mariana Islands**
General Locality **Northern Mariana Islands**
Sub-locality **Rota, Sasanhaya Fish Preserve**

2003

CHIEF OF PARTY

LIBRARY & ARCHIVES

DATE

HYDROGRAPHIC TITLE SHEET

W00156

INSTRUCTIONS — The Hydrographic Sheet should be accompanied by this form, filled in as completely as possible, when the sheet is forwarded to the Office.

FIELD No.

State Commonwealth of Northern Mariana Islands

General Locality Northern Mariana Islands

Sub-Locality Rota, Susanhaya Fish Preserve

Scale 1:10000 **Date of Survey** 09/16/03-09/17/03

Instructions dated N/A **Project No.** OSD-AHB-09

Vessel NOAA R/V AHI

Chief of Party _____

Surveyed by _____

Soundings by echo sounder, hand lead, pole Reson 8101ER MB

Graphic record scaled by _____

Graphic record checked by _____ **Automated Plot** N/A

Verification by Atlantic Hydrographic Branch

Soundings in fathoms feet at MLW MLLW FATHOMS at MLLW

REMARKS: All times in UTC

All soundings corrected with verified tides

Map Projection is UTM zone 55 South

Project: OSD-AHB-09
Registry #: W00156
Territory: Commonwealth of Northern Mariana Islands
Locality: Northern Mariana Islands
Sublocality: Rota, Sasanhaya Fish Preserve
Surveyed by: NOAA R/V *AHI*

The data for this project were collected in support of NOAA's Coral Reef Conservation Program goals to map all shallow (0-30m) coral reefs in US Pacific waters and priority moderate (> 30m) depth areas by 2009. The primary use of the data is to provide bathymetric and backscatter data for previously unmapped areas; in support of ecosystem management requirements for benthic habitat mapping and location of Essential Fish Habitat; and to study the geologic features of the area. It has been determined through the Survey Acceptance Review Process that this data is of suitable quality for nautical chart update purposes.

Data were collected aboard the R/V *AHI* (Acoustic Habitat Investigator), a 25' survey launch owned and operated by the NOAA Pacific Islands Fisheries Science Center in Honolulu, HI. The R/V *AHI*'s survey sensors include a 240 kHz RESON 8101-ER sonar providing bathymetry and imagery data, a TSS/Applanix POS/MV Model 320 which measures position, velocity, attitude and heading, and a Seabird SBE 19 CTD used to measure sound velocity profiles.

Reson 8101ER multibeam Data were collected from 16-17 September 2003, aboard NOAA Survey Launch *AHI* at Guam, Northeastern Island during survey cruise AHI-03-07b. These multibeam data were collected using SAIC ISS-2000 software in the Generic Sensor Format and processed using SABER editing software. Sound velocity corrections from a Seabird SBE19 CTD sensor and motion corrections from a POS-MV vertical reference were applied to the data in real time. Predicted tides were applied to the data in real time.

Horizontal accuracy is 20m (no differential GPS correctors applied), vertical accuracy is depth dependent (~1% of water depth), WGS84 datum. Depths mapped range from 10 - 300 m. The *AHI* was deployed from the NOAA Ship *Oscar E. Sette* and surveyed independently during ship operations in other locations in American Samoa.

For further information regarding survey operations and data processing please see inclusions preceding the Evaluation Report.

APPENDIX V
SUPPLEMENTAL SURVEY AND
CORRESPONDENCE

Multibeam Bathymetric Processing Overview

Data collected using the ISS-2000 software are fully corrected for ship's motion, navigation, sound velocity, and predicted tides (if selected). Using the compatible SAIC SABER processing package (link to manual?), many of these corrections can be re-applied or changed, if desired. In practice at most four processing steps, which have been summarized in a document compiled by PIBHMC personnel (link to SABER How To), are needed for the majority of multibeam bathymetric data collected:

- Application of alternate sound velocity profiles to a limited number of multibeam swath files
- Application of corrected tides (if available and/or needed) to some or all multibeam swath files to replace the predicted tides applied in real time
- Swath editing of all multibeam swath files using the MVE editor (Figure Swath Edit)
- Editing of PFM (pure file magic) grids using the PFM editor (Figure PFM Edit)

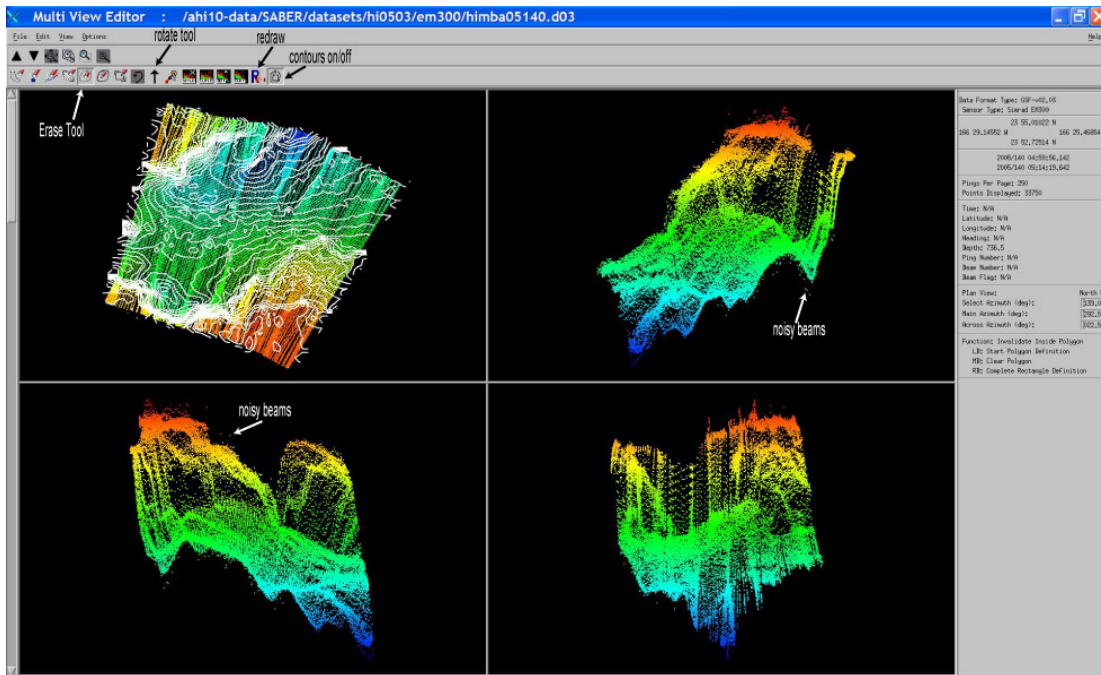

Figure Swath Edit: Individual multibeam swath files are edited with the MVE editor. All changes done with this editor are made to the Generic Sensor Format (GSF) multibeam data files by resetting flags, rather than removing or changing the original data.

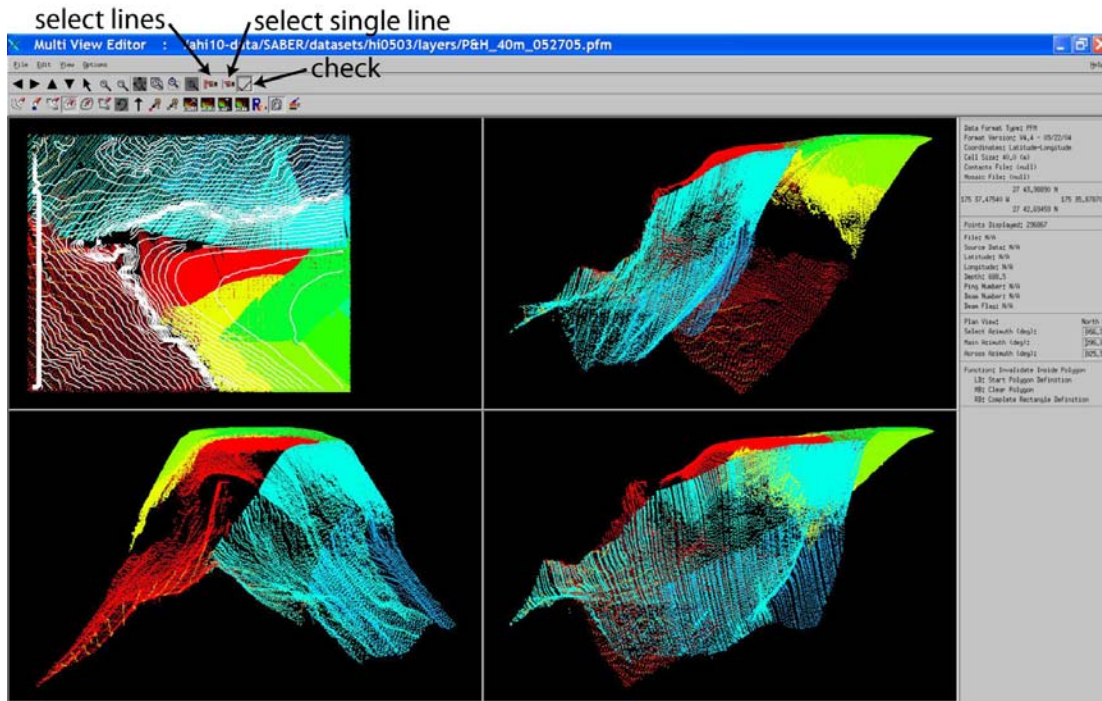
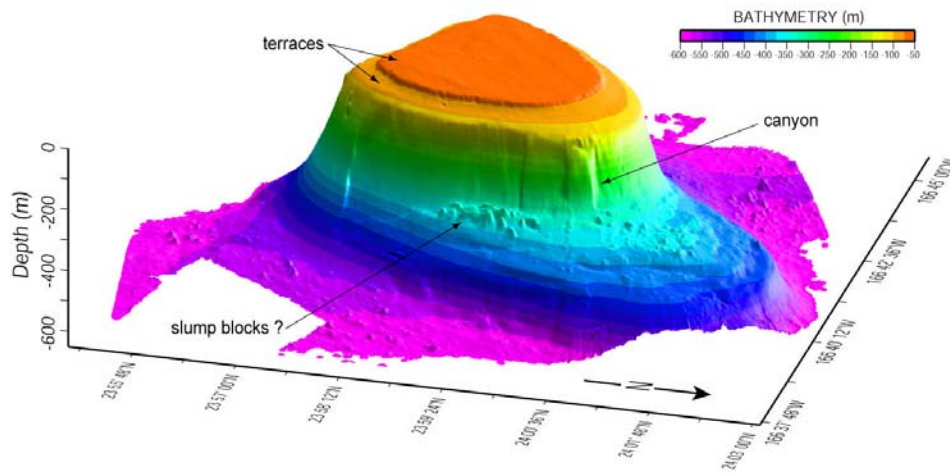

Figure PFM Edit: Several multibeam swaths, represented by different colors, are viewed simultaneously in the PFM editor and the grid can be edited viewing only any combination of files at the same time.

After edits have been made to the PFM grid, the edits are then downloaded back to the GSF files, where flags are set to indicate the edits. These finally processed GSF files are used for data synthesis work at PIBHMC and are documented with FGDC-compliant metadata; the GSF files with metadata are sent to the National Geophysical Data Center (NGDC) on a cruise-by-cruise basis.

After the grid editing is complete, the PFM grid can be downloaded to ascii, xyz or other grid formats or the original GSF files can be regrided and output to these formats. The GSF files, ascii, xyz, and/or grid files can then be transferred to other data processing and visualization packages including:

- MBSsystem: an open source software package for the processing and display of bathymetry and backscatter imagery data derived from multibeam, interferometry, and sidescan sonars (link to <http://www.mbari.org/data/mbsystem/>). MBSsystem is supported by the National Science Foundation.
- GMT (Generic Mapping Tools): GMT is an open source collection of ~60 tools for manipulating geographic and Cartesian data sets and producing output in the encapsulated Postscript (eps) format. It is supported by the National Science Foundation. (link to <http://www.soest.hawaii.edu/gmt/>) (See Figure MBSsystem and GMT Output)



3D Perspective view of Brooks Bank, NWHI looking from 045 degrees. VE = 2x.

Figure MBSsystem and GMT Output. Data processed with SABER were manipulated using MBSsystem and GMT to produce this figure.

- Fledermaus: a commercial product of Interactive Visualization Systems (IVS) (link to <http://www.ivs3d.com/>) for scientific 3-D visualization and analysis of multibeam bathymetry and other standard data formats for high density and resolution data. Figure Fledermaus_Output

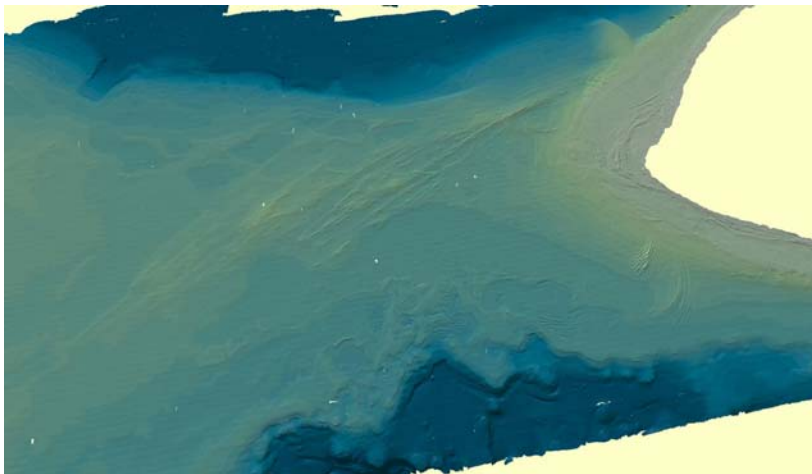
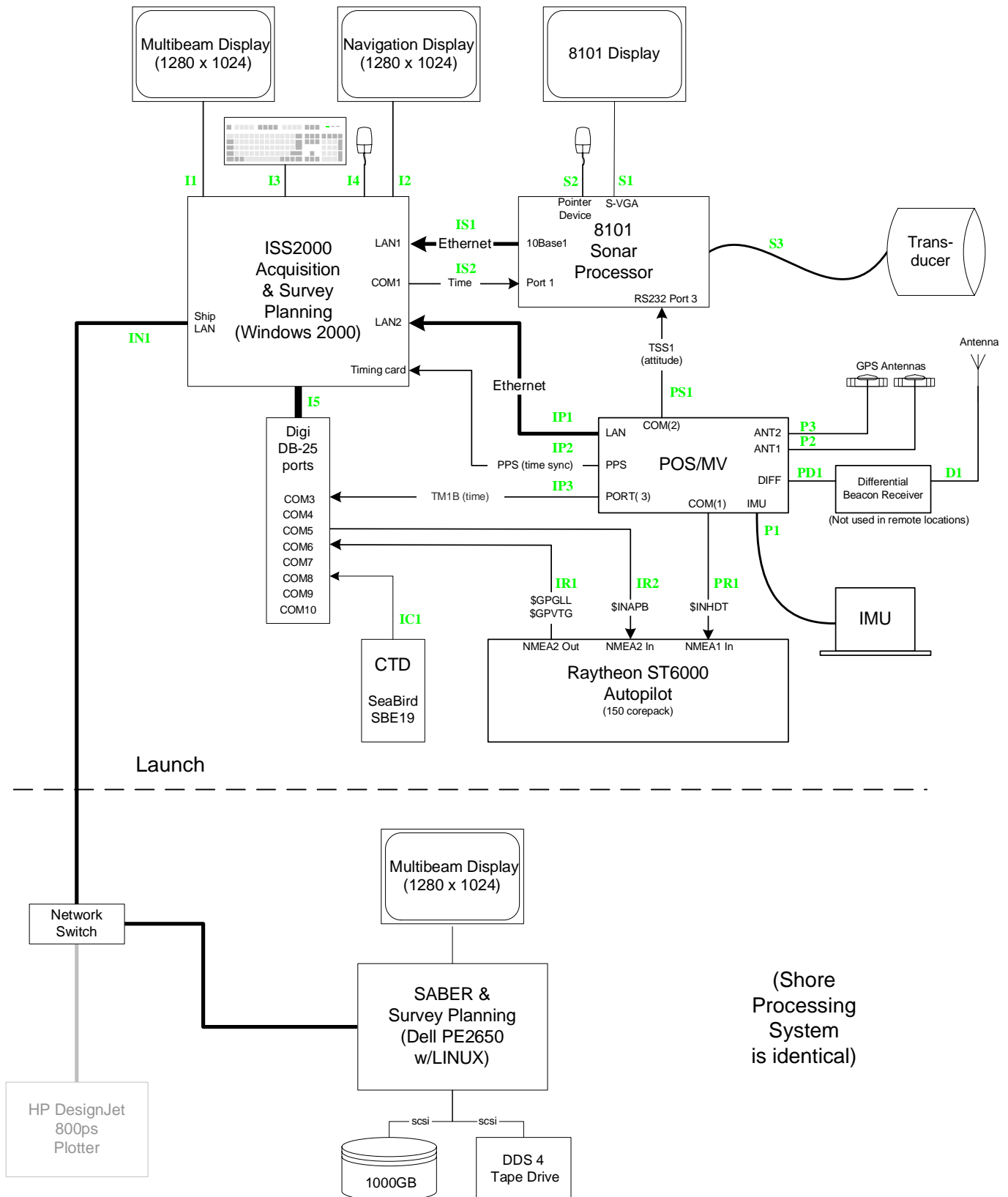

Figure Fledermaus_Output. Fledermaus allows very high resolution 3-D displays of complex surfaces, such as the top of the eastern half of Penguin Bank in the MHI.

- ArcMap: Geographic Information System (GIS) from ESRI Incorporated. ArcMap provides the ability to layer a variety of different outputs for display and analysis.

Acoustic Habitat Investigator (AHI) System Configuration



R/V AHI Safety and Operations Manual



National Marine Fisheries Service
Pacific Islands Fisheries Science Center
Coral Reef Ecosystem Division

Purpose: This document was created to promote safe and standardized operations of the R/V AHI.

Authority: The R/V AHI is owned and operated by the Coral Reef Ecosystem Division (CRED) of the Pacific Islands Fisheries Science Center (PIFSC) in Honolulu, Hawaii. All operations shall be conducted according to the guidelines described within.

Intended Audience: All individuals involved with the daily operations of the AHI shall be familiar with this manual and shall adhere to the policies and procedures described within.

Acknowledgements: Many sections of this manual are based on the USCG Non-Standard Boat Operator's Handbook.

Record of Changes

Revision number	Date of change	Changed by	Summary of changes
1.0	24 Jul 2003	SF	Initial draft
1.1	25 Jul 2003	SF	Addition of Operational Record; edits throughout
1.2	15 Dec 2003	SF	Added AHI Iridium phone # to float plan
1.3	19 Apr 2005	JJ	Change GPS, life vest info, and added Maint sch.
1.4	29 Jan 2007	SF	Updated. Added small boat launch & recovery procedures aboard NOAA ship <i>Hi'ialakai</i> .
1.5	18 Apr 2007	JDC	Added Emergency Procedures section.
1.6	4 May 2007	SF	Review and formatting
1.7	24 May 2007	SF	New Iridium phone numberf

Table of Contents

1.	Vessel description	4
1.1.	Vessel particulars	5
1.2.	Mechanical systems	5
1.3.	Electrical systems	5
1.4.	Deck equipment and ground tackle	6
1.5.	Safety equipment	6
1.6.	Communications equipment	6
1.7.	Navigation equipment	6
2.	Chain of authority	7
3.	Safety procedures	8
3.1.	Personal safety	8
3.2.	Operating parameters	8
3.2.1.	Safe navigation practices	9
3.2.2.	Limitations on operational areas	9
3.2.3.	Vessel speed and trim	9
3.2.4.	Fuel level	10
3.2.5.	Disabling casualties	10
3.3.	Emergency procedures	11
3.3.1.	Anchoring	11
3.3.2.	Using the Sea Anchor	11
3.3.3.	Man Overboard Rescue	13
3.3.4.	Engine Failure	14
3.3.5.	Shipboard Fire	14
3.3.6.	Abandon Ship	14
3.4.	Float plans	15
3.5.	Passengers	16
4.	Launch and Recovery Guidelines aboard NOAA Ship Hi'ialakai	16
5.	Operations records	17
6.	Accident Reporting	17
7.	Periodic Maintenance Plan	17



1. Vessel description

The research vessel AHI (Acoustic Habitat Investigator) is a 25' aluminum-hulled vessel with enclosed cabin as shown in Figure 1. The R/V AHI was designed to transport personnel and survey electronics for seabed mapping surveys in the U.S. Pacific islands. The AHI was outfitted for daytime operations, either working in conjunction with a mother ship such as a NOAA research vessel, or for independent operations based out of small boat harbors in inhabited island groups.

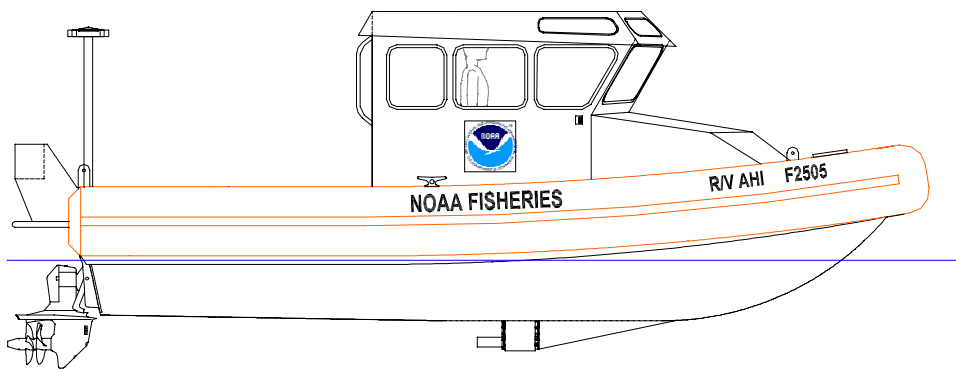

Figure 1: R/V AHI profile drawing

For a vessel of this size, the AHI is designed to be very seaworthy. The hull is built of 5/16" aluminum with three buoyancy tanks integral to the hull. The boat is heavily

constructed in order to withstand routine deployment and recovery from a mother ship via boat davits or ship's crane. A rigid foam collar provides redundant floatation and stability in rough waters as well as protecting the boat when coming alongside the mother ship. The enclosed cabin is air-conditioned and is designed to protect both passengers and survey electronics from the environment.

The AHI was specially built for high-resolution surveying of the seabed in depths from 5 to 200 meters. The hull and cabin house a 240 kHz RESON 8101 multibeam echosounder, a POS/MV position and orientation sensor (with two GPS antennas and an inertial measurement unit), and a small rack of survey electronics and computers. The boat can carry up to six people but typically operates with two or three people, including a coxswain and one or two surveyors. There is no enclosed berthing space. A portable toilet and a cooler for food and water are stored on deck.

1.1. Vessel particulars

- Vessel call sign: WTEQ
- Vessel number: NOAA F2505
- Hull color: Unpainted aluminum cabin and hull with orange foam collar
- Length overall: 25'
- Beam: 10'
- Draft: 3.3'
- Air draft: 8.7' w/life raft on cabin top
12.2' w/ VHF antenna up
- Weight in air: 9,500 lbs
- Weight on trailer: 11,700 lbs

1.2. Mechanical systems

The AHI has a planing hull with a deep-V construction (25° deadrise) and a maximum speed of 21 knots. The boat typically transits at 12 to 18 knots and surveys at 5 to 7 knots. A single fuel tank holds 100 gallons of diesel fuel. Actual fuel consumption varies greatly with engine speed. At a fast transit the boat can use as much as 20 gal/hr, or about 1n mi per gallon of fuel. At survey speeds much less fuel is used. At 12 knots, the boats' range is conservatively estimated at 150 n mi.

The main engine is a 230 hp Volvo Penta KAD43 with dual propeller (DP-S) inboard/outboard drive. The main engine's fuel is delivered through two parallel Racor primary filters and a single Volvo secondary filter. A 3.5 kW Kohler marine generator powers the survey electronics and battery charger. The generator's fuel is delivered through separate primary and secondary filters. The survey electronics and cabin are cooled by an engine-driven air conditioner.

1.3. Electrical systems

Two 12 V marine, deep-cycle 55 A hr. batteries are charged by the main engine's 60 A alternator, the generator's 15 A alternator and a Guest 15 A three-stage battery charger. These batteries are separated to support engine and house loads but a battery combiner automatically charges both batteries. 120 VAC is provided either by the generator or

shore power. A 2200 watt uninterruptible power supply conditions power for the survey electronics.

Navigation lights conform to USCG Navigation Rules (COMDTINST M16672.2C) for motor vessels. Interior and exterior lights are available for day and night operations.

1.4. Deck equipment and ground tackle

- Light anchor: 7 lb Fortress FX-11 with 15' of 5/16" chain and 150' of 5/8" rode
- Heavy anchor: 20 kg (50 lb) Bruce-type with 100' of 5/16" chain and 100' of 3/4" rode
- Chafe protection: 20' old firehose
- Docklines: two 25' and two 15' three-strand 5/8"
- Fenders: 1 small, 3 medium (rigged with a narrow line to fit sea anchor swivel)
- Utility line: 600' of 5/8" double braid used for instrumentation deployment

1.5. Safety equipment

- Three type II auto inflatable PFDs; attached whistles & lightsticks; spare CO₂ cartridges
- Three type II work vests
- Three signal streamers (not attached to PFDs)
- Life ring (type IV) and buoyant cushion (type IV)
- Extendable boat hook
- Throw bag
- Mask, snorkel & fins
- Two paddles
- First aid kit
- Fire extinguishers
 - Main cabin: 11 lb Halotron (A,B,C)
 - Engine compartment: 7 lb FE-241 with automatic & manual activation and engine shutoff
- Two Whale Gulper bilge pumps
- Carbon monoxide alarm
- Handheld 12 VDC Searchlight
- Air horn
- SOLAS flares (1 Mk 3 Parachute, 4 Mk 7 Red, 2 Mk 5 Orange Smoke)
- Sea anchor assembly
- Life raft: 4-man USCG-approved with SOLAS A-pack, cradle & hydrostatic release

1.6. Communications equipment

- Raymarine console-mounted VHF
- Horizon Handheld VHF
- Cellular phone
- Iridium satellite phone

1.7. Navigation equipment

- Magnetic steering compass

- Binoculars with compass
- Handheld bearing compass and Weems plotter
- Paper charts of the operating area
- POS/MV survey-grade position and orientation system providing GPS-derived position, velocity and heading
- Garmin 76Map handheld GPS mounted on console
- RESON survey-grade 8101 240 kHz multibeam echosounder (400 m slant range)
- Raymarine L760+ dual frequency (200 and 50 kHz) echosounder
- Raymarine ST6001 autopilot with heading input from POS/MV
- Nobeltec Visual Navigator with digital charts



2. Chain of authority

As described in the NOAA Small Boat Policy (NAO 217-103), the following personnel are responsible for the safe operations of the R/V AHI. This vessel is designated as a Class I motorboat according to the Small Boat Policy.

- The NOAA Small Boat Program Coordinator is responsible for developing and maintaining the NOAA Small Boat Policy and to facilitate the implementation of this policy.
- The NMFS Line Office Small Boat Officer (LOSBO) is responsible for implementing small boat policy within NMFS.
- The Pacific Islands Fisheries Science Center Director is responsible for all boat operations conducted at PIFSC and for developing a comprehensive policy that covers those operations.
- PIFSC Small Boat Program Coordinator: The Center Director has delegated responsibility for small boat operations to the Small Boat Manger. The Small Boat Manager is responsible for the safe operation, inspection compliance, life cycle management and material condition of all of the PIFSC boats; for developing a vessel policy and/or vessel operations manuals for the boats; for obtaining written guidance from the NOAA Small Boat Program during the development of the vessel policy and vessel operations manuals; and for assigning routine management and oversight of each boat to a responsible person.
- Chief of the Coral Reef Ecosystems Division: The chief of CRED has oversight of the overall scientific operations of the R/V AHI and for ensuring that operations are conducted safely and within the guidelines of the PIFSC vessel policy.

- The CRED Vessel Operations Coordinator (VOC) is responsible for overseeing the division's boats and operators. The VOC is also responsible for managing the division's small boat training operations, training and maintenance.
- AHI Operator-in-charge: The operator in charge of the R/V AHI is the person primarily responsible for this vessel and has oversight of the daily operations of the vessel. This includes routine vessel maintenance, scheduling scientific operations, ensuring that all coxswains are appropriately trained and that operations are conducted in accordance with this manual.
- Coxswains: A list of individuals who are authorized to operate the AHI shall be maintained by the VOC. These individuals must have had the appropriate NOAA small boat training courses and be recommended by the AHI Operator-in-charge. The coxswain may temporarily allow another crewmember to operate the vessel but a designated coxswain must be onboard at all times and shall remain in charge of the vessel.

3. Safety procedures

Safety procedures include those which help ensure personal safety, that the vessel is being operated safely, and that should the vessel become disabled and overdue it will be reported promptly.

3.1. Personal safety

1. Personal floatation devices (PFDs) shall be worn at all times while underway, except in the rare event that diving operations are conducted from AHI, in which case a full wetsuit providing at least 15.5 lbs. of buoyancy may be substituted for a PFD. Personnel operating in the cabin should wear type II inflatable PFDs.
2. Closed-toed shoes shall be worn during deck operations.
3. Hardhats shall be worn when loading and unloading the vessel from the mother ship or when transferring equipment between the boat and the ship.
4. Personnel shall not leave the cabin or the after deck without permission of the coxswain. In particular, personnel shall not walk forward to the foredeck or step over the transom onto the boarding platforms while the boat is underway.
5. Hat, long pants and long-sleeved shirts shall be available should it be necessary to abandon ship.
6. All personnel shall be briefed in the following activities prior to departure:
 - Starting and stopping the main engine and generator,
 - Activation of fire extinguishers,
 - Recovery of Man Overboard,
 - Manual deployment of sea anchor,
 - Manual deployment of EPIRB, and
 - Manual deployment of the life raft.

3.2. Operating parameters

Operating parameters of the R/V AHI include safe navigation practices, limitations on operational areas, matching vessel speed and trim to water conditions, planning fuel usage and identification of disabling casualties which prevent the vessel from being operated.

3.2.1. Safe navigation practices

All vessel actions shall be conducted in accordance with the USCG Navigation Rules (COMDTINST M16672.2C).

3.2.2. Limitations on operational areas

The vessel shall not be operated in the surf zone or in swells near surf breaks!

Coxswains must be aware of the danger of surf breaks. When operating in swells near shore, care must be taken to avoid being “beam to” the seas. Because of the nature of the AHI’s survey equipment is it most natural to survey parallel to the surf break but should anything go wrong (e.g., engine failure or a large swell) the boat could be set into the surf break. Avoid the temptation to survey into these regions.

As a general rule, the vessel shall not be operated in less than ten feet (three meters) of water. Survey operations should not be conducted in less than 20 m of water in most circumstances. If there is no swell and conditions otherwise permit, survey operations may be conducted into waters as shallow as 10 meters. Be very cautious when surveying in remote areas. Recall that damaging the I/O drive can disable the vessel and that the sonar transducer costs \$235,000. In very calm conditions, it may be acceptable to navigate in water shallower than ten feet but it must be at idle speed and with great caution.

Although the AHI is very ruggedly designed, it is not equipped to operate in the open ocean or in remote areas unattended. Operations in these areas shall not be undertaken without an escort vessel. Transits between islands or channel crossings may be undertaken unattended only if a written float plan has been filed that describes the transit, and the vessel is in communication with the shoreside person responsible for monitoring the float plan. At a minimum the shoreside contact must be informed of the time the vessel is entering the channel and estimated time the crossing will be completed. The shoreside contact must also be informed once the crossing is over.

3.2.3. Vessel speed and trim

A large number of small boat mishaps can be attributed to excessive speed. Generally, the coxswain will be the last person onboard to tire as he or she can instinctively adjust his or her stance and body position to the conditions. Speed is hard on the body and on equipment. The AHI is equipped with some very expensive equipment. You don’t want to be the coxswain that hurts someone or damages equipment because of excessive speed. As a crewmember, never hesitate to ask the coxswain to slow down or take up a more forgiving heading.

The trim of a planing-hulled vessel can have a significant impact on hull efficiency, engine performance and reduction of impact stress. Once the vessel is brought up on a plane the trim can be adjusted to reduce water contact (drag). The ideal trim angle is found by gradual manipulation of the trim controls in various sea states until the coxswain becomes acclimated to the hull’s response in a variety of conditions. The following are general guidelines for proper trimming of a planing vessel:

- Bring the boat onto a plane in fairly flat water and trim up (positive numbers on the trim display) to free the hull from the water and reduce drag. Trimming up (or out) raises the bow. If you trim up too far the bow will rise and begin to bounce.

- Trimming down (in) will tuck the outdrive closer against the transom. The boat will handle better when driving into waves but will slow down and create more spray.
- When properly trimmed, the controls will feel light to the touch, speed will increase and spray will be reduced. This is because less wetted surface area of the hull is in contact with the water.

Recall that the AHI has a large sonar transducer on the keel (figure 1). This protrusion has a significant effect on vessel operation. When planing, the sonar remains in contact with the water and causes drag which reduces the hull's speed by at least ten knots over other vessels of this design. You will also notice a spray of water to be ejected out either side of the vessel. Trim still has an effect on the AHI's performance but it is not as noticeable as with other boats.

Another effect of the sonar dome is that the AHI does not track straight at idle speed. The boat seems to pivot about its center so care must be taken when maneuvering alongside a dock or ship.

3.2.4. Fuel level

The amount of fuel onboard the AHI is a critical limitation for any operation. When conducting routine operations the vessel should be fueled any time the fuel gauge indicates less than 5/8 full. The fuel tank is not rectangular; the lower half of the tank contains less fuel than the upper half. Proper mission planning should include completing the operation with at least 25 gallons of fuel remaining (3/8 on the gauge).

gallons	Amount in Tank	Amount to Fill
Full	111	0
7/8	95	16
3/4	79	32
5/8	63	49
1/2	46	65
3/8	30	81
1/4	16	95
1/8	8	103
Empty	0	111

3.2.5. Disabling casualties

Disabling casualties are those which make the boat unserviceable. If a disabling casualty is identified when the AHI is moored, *the boat shall not get underway until the casualty is corrected.* The following is a list of disabling casualties:

- Engine fails to start.
- Engine overheats or is operating above normal temperature range.
- Engine controls (throttle & shift) are inoperable.
- Engine kill switch (motor safety lanyard) is inoperable or missing.
- Engine fails to shift into and out of gear (forward or reverse).
- Engine trim mechanism fails to operate.
- Engine and generator emergency alarms are inoperative.
- Any electrical arcing or sparking occurs.
- Battery boxes are not properly secured.
- Batteries are not covered or protected against accidental contact with other objects.
- Batteries will not charge.
- Steering system is inoperable or restricted (binding or less than full movement).
- Any fuel or lube oil leaks are dripping on a hot portion of the engine or generator.
- Magnetic steering compass is missing or inoperable.
- Both radios are inoperable.
- Both echosounders are inoperable.

- Either bilge pump is inoperable.
- Either cabin or engine compartment fire extinguisher are inoperable.
- Foam collar is loose, incomplete or otherwise not secure.
- Any hull breach or structural damage to hull or cabin.

3.3. Emergency procedures

3.3.1. Anchoring

Guidelines

- AHI should always be anchored from the bow; anchoring from the stern causes the vessel to become less stable and exposes the cabin and engine to flooding. Anchor from the stern only if anchoring from the bow becomes impossible or hazardous.
- Use 7:1 scope in rough weather, 5:1 scope under normal conditions, and whatever scope is sufficient in calm conditions (Ref: Bruce Anchoring Group, Fortress Marine Anchors). Generally, more scope is required on sediment bottoms; if the angle between the bottom and the anchor line is too great, the anchor will be unable to dig itself into the sediment. Be aware that increased scope increases the anchor's load capacity, and accordingly makes it more difficult to recover.
- To recover an anchor, slowly move the boat to a position directly over the anchor, pulling in the line as you go. If you cannot release the anchor by hand, snub the line on a cleat and power backwards slowly to pull the anchor out of the bottom. Do not power forward because that will require more energy and put very heavy loads on the anchor and gear. (Adapted from www.fortressanchors.com.) If powering in reverse does not work, consider powering forward briefly. Failing that, try alternately pulling and slackening the line a few times by hand, then making it fast again and powering backward. As a last resort in freeing a stuck anchor, a mask, snorkel and fins are stowed on board.

Equipment

AHI is equipped with two anchors: a light aluminum Fortress anchor, stored in the bow hatch; and a heavy steel Bruce anchor, stored inboard at the stern.

The Fortress is compact and light and is stowed in the small forward hatch. Called a 'lunch hook', its intended use is for brief, elective anchorings under calm conditions, such as lunch breaks.

The Bruce is a 'working anchor' with a much higher holding capacity than the Fortress. This is the anchor to use in case of emergency or elective anchoring under significantly choppy conditions. However, because it is too large to fit into the forward hatch, it is mounted inboard at AHI's stern. In order to deploy the Bruce, the line must first be run forward and wrapped to the front post. If the anchor is deployed before running the line forward, there will likely be too much tension on the line to safely move the line, and the anchor will have to be made fast to the stern, creating an unstable ride.

In a dire emergency where time is of the essence, the Fortress may be deployed to slow AHI's drift while the Bruce is being rigged.

3.3.2. Sea Anchor

The purpose of a sea anchor is to slow the drift of a disabled vessel in the open ocean. Slowing the drift of a vessel improves the chances of a successful vessel rescue or

recovery from a last known position. It might be used, for example: to conserve fuel if lost at sea and separated from the mother ship; or if AHI needs to be abandoned and recovered at a later time.

Equipment

- Three parts: parachute (yellow bag), parachute retrieval line (red bag) and utility line (blue bag)
- Storage: in the extreme bow of the forward crawl space inside the cabin
- Additional equipment: 1 medium/large fender, stored inboard at AHI's stern

Assembly and preparation

- Engine: shift to neutral or turn off, if not already, as lines are likely to fall in the water after this point
- Location: Readyng the sea anchor for deployment is ideally done on the bow, if conditions permit, because it will ultimately be attached to the front post. If weather prohibits assembly on the bow, it may also be done aft prior to walking the equipment forward for deployment.
- Open the chute bag (yellow), pull out ONLY the swivel assembly (leaving the chute inside the bag), undo the shackle and use it to attach the chute to one end of the utility line (blue bag). Scott/Joyce: although the shackle pin is moused to the shackle, the shackle is not moused to the sea anchor itself. If you have any spare time, or if others do, this could be worth doing.
- Tie medium/large fender to the small swivel attached to the bottom of the yellow bag. This will be the extreme end of the sea anchor.
- Attach the bag/bottom end of the retrieval line (red bag) to a rail or cleat out of the way of the bow post.
- On the bow, flake out about 20' of utility line (blue bag) on deck and take a wrap around bow post to make it temporarily fast.

Deployment

- Check the direction of the boat's drift. If the boat is still orienting itself in the wind, consider waiting for the swing to stop before deployment. The sea anchor must be deployed **upwind of the vessel**, or the vessel will drift down on the sea anchor, possibly leading to tangled lines. This can (1) present a sudden hazard to crew by knocking them overboard or pinching body parts, and/or (2) foul the sea anchor assembly on AHI's transducer, preventing the anchor from deploying properly and possibly damaging the transducer.
- After getting the coxswain's okay, throw the chute bag (yellow), recovery line bag (red) and float overboard, upwind. As AHI drifts away from the assembly, the utility line should become taut, pulling the chute out of the bag. The chute may require a sharp jerk or two on the utility line to assist deployment.
- Once out of the bag, the chute will open naturally under tension as it is pulled through the water. Once the chute is opened, allow up to 30 seconds or so for AHI to re-orient itself under the tension of the sea anchor.
- Begin paying out the utility line. AHI now acts as a pendulum at the end of the utility line. In general the more line you pay out, the more gently the AHI will swing from the sea anchor in the current. The gentlest ride is achieved when the distance between the sea anchor and AHI is equal to the wave interval.
- **Be careful not to lose the recovery line.** If it's not long enough to match the distance between swells, you may consider extending the line with another length on board,

but be very sure of your knot. Without this line, it is extremely difficult to recover the sea anchor.

Retrieval

- Engine: If engine power has been restored, keep the engine in neutral during sea anchor retrieval, as slack lines will likely be in the water
- Haul in on the sea anchor recovery line. Since it is attached to the far side – or outside – of the chute, this action will collapse the chute. Once the leading edge of the chute is on board, you may begin hauling in the utility line. (Note: if you haul in the utility line at the same time as the recovery line, the sea anchor may catch the current and redeploy.)
- Once all gear is on board, communicate that information to the coxswain so they know they are free to put AHI in gear.

3.3.3. Man Overboard Rescue

Since the typical AHI survey crew consists of two people, the most likely MOB scenario will leave only the coxswain on board. The coxswain must be prepared to deal with this situation.

- Locate the MOB, note position, request assistance
 - If you do not have a visual on the victim:
 - i. Immediately note the vessel's position and heading; take a waypoint or write down the coordinates
 - ii. Turn around and retrace your route on a reciprocal heading. If survey equipment is logging, consider disabling logging so your previous track and heading remains apparent on the display. This could be useful in searching the area.
 - iii. Send a radio broadcast
 1. If operating from a mother ship, alert the Officer On Duty, give position & status, inform of plan and request assistance if necessary
 2. If operating in coastal areas, alert all boats in the area of MOB situation: to proceed with caution and assist with search, if necessary
 - iv. Consider throwing a life ring, cushion, or other PFD overboard. This will (1) serve as a drifter drogue, possibly indicating the direction of the victim's drift, and (2) create the chance that the victim will find a PFD to assist them in remaining afloat.
 - If you establish visual contact with the victim, maintain visual contact as you complete the next steps.
 - i. Send a radio broadcast; if you are the only person aboard, you will be required to go aft to help get the victim aboard. If you should fall overboard also, someone must have knowledge of your position and status.
 1. If operating from a mother ship, alert the Officer On Duty, give position & status, inform of plan and request assistance if necessary
 2. If operating in coastal areas, alert all boats in the area of MOB situation: to proceed with caution and assist with search, if necessary

- Prepare for rescue
 - Scan your surroundings for reefs, boat traffic, or any other hazards which will affect your rescue
 - If safe to do so, consider signaling to the victim to reassure them
 - Prepare the boat hook and/or throwbag. Remove them from storage; extend boat hook, open throwbag, and ready them for easy access. Fasten the cockpit door open
- Victim Recovery
 - Motor slightly downseas of the victim so that after your turn you can approach directly upseas in a straight line. Approach victim slowly, but with enough momentum to drift 10-20' after shifting to neutral. Steer so as to bring the victim alongside; avoid aiming directly at them and turning the wheel at the last second.
 - When within 10' of the victim, shift into neutral. Go outside and extend the boat hook to the victim, or throw the throwbag. Assist the victim aboard if necessary, **taking extreme care not to fall overboard yourself.**
- Notify NOAA ship or other boats once all passengers are aboard

3.3.4. Engine Failure

- Anchor immediately if possible (see Sect. 3.3.1). Otherwise, prepare for anchoring in the event that the bottom becomes shallow enough to anchor. Also, mentally prepare to **abandon ship, but only as a last resort** (see Sect. 3.3.6)
- Determine direction of drift (GPS/visually/from multibeam bathy display). Consult charts and/or multibeam coverage monitor to anticipate path of drift.
- Radio NOAA ship or Coast Guard. Inform of location, direction of drift, & status; request assistance.
- If drifting offshore, consider deploying sea anchor (see Sect. 3.3.2)

3.3.5. Shipboard Fire

- Kill engine
- Extinguish fire
 - Automatically in engine compartment (do not open hatch)
 - Manual override in engine compartment (do not open hatch)
 - Manually with extinguisher beside passenger's seat. Aim at base of flames in short bursts. **DO NOT USE WATER.**
- Evacuate cabin to bow or stern; grab fire extinguisher, handheld radio, GPS and Iridium phone (in its case) if possible; also First Aid kit and water
- Mentally review steps for abandoning ship, and remember to **abandon ship only as a last resort** (see Sect. 3.3.6)
- If fire is extinguished, contact NOAA ship or Coast Guard. Inform of location, status and request immediate assistance. Do not attempt to restart AHI.
- Anchor AHI, if safe and feasible

3.3.6. Abandon Ship

- *Resist abandoning ship:* Abandoning ship should always be considered a last resort, for several reasons. It provides: shelter (slowing or preventing hypothermia, sun exposure, dehydration, psychological distress, threat from predators, separation from crewmates, etc.); safety, navigation & communication equipment; a stable environment; and a greater possibility of sighting and rescue.

- *Reasons to abandon ship:* There are several scenarios in which crew might be forced to abandon ship.
 - Catastrophic fire, imminent entry to surf zone and imminent high impact collision are situations of sudden life-threatening peril in which crewmembers may be best off simply abandoning ship without hesitation or preparation. In this case, crew members are advised to stay nearby if possible and reboard AHI if the danger passes; or swim for shore.
 - Other scenarios, such as a slow-spreading fire, an eventual entry to surf zone, or a broken davit on the mother ship may allow crewmembers some preparation time and a more orderly evacuation. (AHI is very unlikely to sink; it will float even with the cabin filled.)
- *Preparation:* There are items which can be lifesaving if you manage to grab them
 - Handheld radio, GPS, Iridium phone (in its case), First Aid kit, water, mask/snorkel/fins
- *Manually deploy life raft and EPIRB*
 - EPIRB: remove pin and pull up. Life raft: undo pelican hook and push raft overboard if necessary
 - Load all above items and personnel into the life raft, and but keep life raft attached to AHI by the life raft's painter as long as you can safely do so. The life-threatening situation may resolve itself (e.g., a fire burns itself out), and you may be able to stay in the more protected environment of the AHI. If you are able to re-board AHI, be sure to keep all the critical equipment with you, in case the life raft becomes parted from AHI accidentally.
- *Conserve:* Use your communications equipment and water judiciously
- *Morale:* Draw strength from each other, and from the rescue crew which you can expect to begin searching for you. Survival favors those who can maintain a positive outlook.

3.4. Float plans

Your diligence in filing a float plan is critical to your chance for rescue, so that minimal time is lost in the initiation of search and rescue operations in the event of emergency.

- Float plans will be filed any time the vessel is operated beyond the sea buoy of the harbor. A float plan form is included in Appendix A.
- Float plans must include, at a minimum, the vessel name, date & time of departure, intended destination or working area, estimated date and time of arrival, the names of persons onboard and the type of operation planned. The float plan will designate a person on shore who is responsible for determining whether the vessel is overdue and will initiate appropriate action as designated by the float plan.
- For operations that will take less than twelve (12) hours and will not require crossing a channel or otherwise operating in the open ocean, a verbal float plan may be filed.
- For operations that will take longer than twelve (12) hours, or will require crossing a channel or otherwise operating in the open ocean, a written float plan is required. This plan shall be accompanied by a tracking and communications procedure that requires the boat to report its position at least twice a day.
- Each person embarking on the vessel must have on file a list of emergency contact information. If contact information is not already on file, it may be added to the float plan. An emergency contact information form is included in Appendix B.

3.5. Passengers

Passengers (non-mission critical personnel) may not be transported aboard the AHI unless approved by the Center Director or his designee. Such passengers may include members of the media, guests, VIPs or service organizations. Approvals will normally be granted when such actions are in the best interest of the Government; the boat is being used for official purposes; and the passengers will not interfere with normal operations.

The boat operator may authorize the boarding and carriage of passengers in emergency situations involving the protection of life at sea.

4. Launch and Recovery Guidelines aboard NOAA Ship *Hi'ialakai*

The following guidelines were provided by the command aboard the NOAA Ship *Hi'ialakai*:

Each day prior to boat launch, and in conjunction with the morning dive briefing, an announcement will be made detailing both morning boat coxswains and who in Deck will be in charge of morning deployments. Details for coxswain and Deck boss assignments for afternoon boat retrievals will be communicated when the respective boats make their “ten minutes out” call to the ship. The Chief Bosun will have the final decision in these assignments.

When launching and recovering boats, the radios of all principal personnel will be set to 82 Alpha to facilitate and streamline communications.

When launching and recovering boats, communication between the Deck and the small boat will be conducted *solely* between the designated “Deck Boss” and boat coxswain. The only exception is if a safety issue or concern is detected by someone else on Deck or in the boat crew. Otherwise all communications will be channeled through the designated parties in charge.

Launching of all small boats will be done at speeds necessary for the Ship to maintain steerageway; unless conditions dictate otherwise. HI-1, HI-2, and Program-supplied Safe Boats will be launched into the seas while AHI will be launched down swell; unless conditions dictate otherwise. Inflatables will be deployed with the Ship at bare steerage or “All Stop” unless conditions dictate otherwise.

Recovery of small boats will be done at roughly 2-4 knots when retrieving boats upswell. This would include HI-1, HI-2, and Program-supplied Safe Boats; unless conditions dictate otherwise. AHI will be recovered downswell at roughly 4-6 knots unless conditions dictate otherwise. Inflatables will be recovered with the Ship maintaining bare steerage or at “All Stop” unless conditions dictate otherwise.



Boats being deployed upswell will cast off the stern line first and the bow line last at the coxswain's direction. Boats being deployed downswell will cast off stern line first and bow line last, again at the coxswain's direction. Boats being recovered upswell will attach the bow line first and stern line last at the coxswain's direction. Boats being recovered downswell will attach the bow line first and stern line last at the coxswain's direction.

As is the case with boat coxswains; personnel handling lines, hooks or davit falls shall demonstrate the required skills necessary to complete their duties to the satisfaction of both the Chief Bosun and the Command. In addition, it should be understood that personnel in training or still somewhat new at their assigned tasks may not be capable of completing the same tasks in more severe conditions. Again, just like coxswain qualifications and abilities or Deck personnel involved in crane and davit operation. The Chief Bosun will have the final say in these matters.

5. Operations records

- An operational record form shall be filled out each time the vessel gets underway. The objectives of the operational record are to guide the coxswain in assessing whether the weather, the personnel and the vessel and its equipment are able to safely conduct operations and to record the type of operation being conducted.
- Operational records are the primary means of recording the daily operations of the R/V AHI. The operational record consists of a departure checklist, a brief description of the times and type of operations, and an arrival checklist. Appendix B contains an operations record form.
- The operations record is not a scientific or a maintenance log; this information shall be recorded elsewhere.
- Any fueling operation, failure of the vessel's equipment or maintenance required while underway shall be recorded.

6. Accident Reporting

Any collision, unintentional grounding, injury to personnel, discharge of oil or fuel, extensive flooding of the vessel or damage to a protected or endangered natural resource shall be recorded in the Operations Record. Any such incident shall be reported immediately to the vessel's captain and the CRED Vessel Operations Coordinator.

7. Periodic Maintenance Plan

Periodic maintenance for the boat's engine and the generator are outlined in the following tables.

Engine Maintenance Checklist

Task	50 hrs	100 hrs	200 hrs	500 hrs	14 days	2 yrs	Pt #, grade, viscosity, and/or volume
Lube steering shaft bearings	X						
Engine oil and filter change		X					VDS-2SAE, 15W/40, 11.0 litre with filter change
Compressor check oil level		X					Oil part # 1141641-9, .1 dm ³
Air filter change		X					Volvo Part # 876185-0
Drive belt (check tension)		X					Volvo Part # 861564
Power steering belt (check tension)		X					Volvo Pt # 973487
Fuel filter/ Prefilter change		X					Volvo Part # 3588378/ Racor Part # 411298
Coolant change			X				20 Litres 50% H2O and 50 % Volvo Pt# 9434699-6
Exhaust pipe check			X				
Seawater pump (check impeller)			X				Volvo Pt # 877061
DP Drive oil change			X				API G 15, SAE 75W/90, PT # 1141634-4
DP Drive check joint and exhaust bellows			X				
DP Drive Re-tighten steering helm screws			X				
DP Drive belt change, compressor			X				
DP Drive belt change, circulation pump			X				Volvo Pt # 977542
Valve clearance adj.				X			0.40 mm (cold eng)
Turbo check				X			
Racor, drain water					X		
Drive belts check					X		
Sea water filter cleaning					X		
Battery, check electrolyte levels					X		
Drive, check corrosion protection					X		
Power trim pump, check oil level					X		Dexron-III (auto trans fluid)
Steering, check oil level					X		
DP Drive change universal joint						X	
DP Drive change exhaust bellows						X	

Generator Maintenance Checklist

Task	Daily	50 hr 1 mo	100 hr 3 mo	200 hr 6 mo	400 hr 12 mo	600 hr 18 mo	Part #'s
Check for abnormal Fuel injection sound	X						
Check crankcase oil level and add oil as necessary	X						HD (API) CD,CC/CD,or CC: 10W/40: 1.25 qt
Check seawater outlet and clean as necessary	X						
Inspect the exhaust system components	X						
Check exhaust gas condition. If blue or black contact Mechanic	X						
Check for water, fuel, and oil leakage	X						
Retighten any loose nuts or bolts	X						
Check and tighten the electrical connections		X					
Remove the sediment from the fuel tank and drain the fuel tank			X				
Replace the oil in crankcase			X				
Check the anode			X				GM20853 (kohler)
Check the seawater pump seal and impeller			X				GM 20852 (Kohler)
Adjust the intake/exhaust valve clearance			X				
Replace the fuel filter				X			GM20850 (Kohler)
Clean the oil strainer				X			GM24013 (kohler)
Clean the intake silencer element				X			GM20848 (kohler)
Check the mounting bolts/vibromounts and tighten If necessary				X			
Check the fuel injection nozzles/check the injection spray condition					X		
Replace the seawater pump seal and impeller					X		
Replace the intake silencer element					X		
Inspect the complete exhaust system					X		
Clean the battery cables					X		
Check the remote control operation					X		
Blow dust out of the generator					X		
Clean the filter insers of the fuel transfer pump						X	
Replace the anicorrosion zinc anode						X	

Appendices

- A. Float Plan
- B. Emergency Contact Form
- C. Operational Record
- D. Preventive Maintenance Checklist

R/V AHI Float Plan



Call sign:	WTEQ
	VHF base and handheld radios
Hull number:	NOAA F2505
Hull color:	Unpainted aluminum cabin & hull with orange foam collar
Length overall:	25'
Beam:	10'
Draft:	3.3'

Engine: single 230 hp diesel w/ I/O drive
 Transit speed: 12 – 18 kts

Fuel capacity: 100 gal
 Operational speed: 5 – 7 kts

Safety equipment:

- Life raft: 4-man USCG-approved with SOLAS A-pack, cradle & hydrostatic release
- EPIRB: 406 MHz Cat I, ID: ADCD0237E941801
- Life ring (type IV) and buoyant cushion (type IV)
- Six PFDs (3 type II inflatable vests, 3 type III workvests) with whistles and lightsticks
- SOLAS flares (1 Mk 3 Parachute, 4 Mk 7 Red, 2 Mk 5 Orange Smoke)
- Fire extinguishers
 - Main cabin: 11 lb Holatron (A,B,C)
 - Engine compartment: 7 lb FE-241 with automatic & manual activation and engine shutoff

Cell phones: _____

Satellite phone: **8816 316 15197**

Departure location: _____

Date & time of departure: _____

Intended working area: _____

Type of operation: _____

Intended arrival location: _____

Estimated date & time of arrival: _____

Names of persons onboard: _____

Communications plan : _____

Boat problems or other notes: _____

Emergency Contact Form

Name: _____

Address: _____

Home phone: _____



Next of kin: _____

Relationship: _____

Address: _____

Home phone: _____

Work phone: _____



Other contact: _____

Relationship: _____

Address: _____

Home phone: _____

Work phone: _____

Operational Record

Date: _____ Coxswain: _____

Intended operating areas: _____

Intended transit distances: _____

Weather forecast: _____

Adverse Weather conditions? _____

Record fuel level: _____ (fraction of tank) Enough for work? Y / N

Persons on board: _____

Float plan filed? Y/N Responsible person ashore: _____

Departure Checklist done? Y / N Startup Checklist done? Y / N

Point of Departure: _____ Departure time: _____

Transit RPM & Speed: _____ Transit time: _____

Operating area: _____ Arrival time: _____

Operating RPM & Speed: _____ Time of departure: _____

Transit RPM & Speed: _____ Transit time: _____

Operating area: _____ Arrival time: _____

Operating RPM & Speed: _____ Time of departure: _____

Transit RPM & Speed: _____ Transit time: _____

Operating area: _____ Arrival time: _____

Operating RPM & Speed: _____ Time of departure: _____

Transit RPM & Speed: _____ Transit time: _____

Point of Arrival: _____ Arrival time: _____

Float plan closed? Y / N

Shutdown Checklist done? Y / N Arrival Checklist done? Y / N

Layup Checklist done? Y / N / NA Accident report required? Y / N

First Aid kit replenishment needed? Y / N _____

Equipment Problems? Y / N _____

Preventive Maintenance Needed? Y / N _____

Actions required prior to next departure: _____

Operational Record Checklists

Date: _____

Coxswain: _____

Departure Checklist

Daily:

- Check PFD activation cartridges
- Check Raymarine VHF radio
- Check handheld VHF radio
- Check cellular phone battery & signal
- Check Garmin GPS position
- Check POS/MV position
- Check Raymarine echosounder
- Check RESON echosounder
- Check Raymarine autopilot
- Raise Antennas if needed
- Mount EPIRB if needed
- Store Food & water onboard

Weekly check (1st day of week)

- Inspect life raft & hydrostatic release
- Inspect Iridium satellite phone
- Inspect handheld Searchlight

Monthly or beginning of operation

- Check cabin fire ext. charge
- Check eng. fire ext. charge (use mirror!)
- Check first aid kit contents
- Check flares & smoke canisters
- Test Air horn
- Test EPIRB
- Check hand bearing compass
- Verify paper charts are onboard

Arrival Checklist

- Back up data
- Shut down ISS-2000 computer
- Turn off RESON & POS/MV
- Turn off survey UPS
- Turn off Raymarine VHF
- Turn off handheld VHF
- Turn off Chartplotter
- Turn off autopilot
- Clean cabin
- Stow EPIRB (if necessary)
- Stow antennas (if necessary)
- Cell phone off or ashore
- Secure Iridium phone
- Clean and wash down deck & cabin
- Clean cooler
- Take food ashore

Layup Checklist

- Stow EPIRB
- Stow antennas
- Check drive lube oil level
- Check zincs
- Flush generator with fresh water
- Flush engine with fresh water

Startup Checklist

- Turn both battery switches on
- Record engine hours: _____
- Inspect engine compartment.
- Look for leaks or dripping water
- Open generator & air conditioning seacocks
- Inspect Bilges:
 - Excessive water? Y / N
 - Oil in water? Y / N
- Check bilge pump operation
- Check engine oil level
- Check water coolant level
- Check steering hydraulic fluid
- Check trim motor hydraulic fluid
- Check engine raw water strainer
- Check air conditioning water strainer
- Check generator water strainer
- Check tension on all belts
- Record genset hours (on housing) _____
- Inspect generator
- Check generator oil level
- Secure dockside power
- Start engine
- Air conditioning fan on
- Check engine and air con. water flow
- Start air conditioning
- Start generator
- Check steering Center steering
- Check I/O trim Set trim to 0°
- Turn on UPS
- Start POS/MV & RESON
- Start ISS-2000 computer
- Is prestart maintenance required? Y / N

Maint. Actions: _____

Shutdown Checklist

- Trim I/O down to -4°
- Turn generator off
- Turn air cond. off
- Turn engine off
- Record engine hours
- Record fuel level
- Record generator hours
- Inspect generator
- Inspect engine compartment
- Inspect for leaks or dripping water
- Inspect bilges
- Inspect strainers
- Connect power cord (if necessary)
- Close seacocks (if necessary)
- Turn all circuit breakers off
- Turn both battery switches off

AHB COMPILATION LOG

General Survey Information	
REGISTRY No.	W00156
PROJECT No.	OSD-AHB-09
FIELD UNIT	R/V AHI
DATE OF SURVEY	16 SEPTEMBER 2003 – 17 SEPTEMBER 2003
LARGEST SCALE CHART	<i>81063, edition 1, 20030325, 1:25,000</i>
ADDITIONAL CHARTS	
SOUNDING UNITS	fathoms
COMPILER	Kolleen McKenzie

Source Grids	File Name
	H:\Compilation\W00156_AHI_ROT\AHB_W00156\
	E-SAR Final Products\GRIDS\W00156_AHB_1m_Final
	E-SAR Final Products\GRIDS\W00156_AHB_2m_Final
	E-SAR Final Products\GRIDS\W00156_AHB_4m_Final
	E-SAR Final Products\GRIDS\W00156_AHB_8m_Final
Surfaces	File Name
	H:\Compilation\W00156_AHI-ROTA\AHB_W00156\COMPILE\Working
<i>Combined</i>	W156_AHB_Comb_8m.hns
<i>Interpolated TIN</i>	\Interpolated TIN\W00156_8m_InterpTIN.hns
<i>Shifted Interpolated TIN</i>	\Shifted Surface\W00156_8m_InterpTIN_Shifted10fm.hns
<i>Shifted Interpolated TIN</i>	\Shifted Surface\W00156_8m_InterpTIN_Shifted100fm.hns
<i>Product Surface</i>	
Final HOBs	File Name
	H:\Compilation\W00156_AHI-ROTA\AHB_W00156\COMPILE\Final_Hobs\
<i>Survey Scale Soundings</i>	W00156_SS_Soundings.hob
<i>Chart Scale Soundings</i>	W00156_CS_Soundings.hob
<i>Contour Layer</i>	W00156_Contours.hob
<i>Feature Layer</i>	W00156_Features.hob
<i>Meta-Objects Layer</i>	W00156_MetaObjects.hob
<i>Blue Notes</i>	W00156_BlueNotes.hob
<i>ENC Retain Soundings</i>	

Meta-Objects Attribution	
Acronym	Value
M_COVR	
CATCOV	coverage available
SORDAT	20030917
SORIND	US,US,graph,W00156
M_QUAL	
CATZOC	zone of confidence U (data not assessed)
INFORM	W00156,OSD-AHB-09,R/V AHI
POSACC	
SORDAT	20030917
SORIND	US,US,graph,W00156
SUREND	20030917

[Type text]

This Document is for Office Process use only and is intended to supplement, not supersede or replace, information/recommendations in the Descriptive or Evaluation Reports

SURSTA	20030916
DEPARE	
DRVALV 1	0.82021 fm
DRVALV2	148.29724 fm
SORDAT	20030917
SORIND	US,US,graph,W00156
M_CSCL	
CSCALE	
SORDAT	
SORIND	

SPECIFICATIONS:

- I. COMBINED SURFACE:
 - a. Number of ESAR Final Grids: 4
 - b. Resolution of Combined (m): 8

- II. SURVEY SCALE SOUNDINGS (SS):
 - a. Radius
 - b. Shoal biased
 - c. Use Single-Defined Radius (mm at Map Scale): ; Radius Value = 1
 - d. Queried Depth of All Soundings
 - i. Minimum: 0.82021 fm
 - ii. Maximum: 148.29724 fm

- III. INTERPOLATED TIN SURFACE:
 - a. Resolution (m): 8
 - b. Linear
 - c. Shifted value: -0.229m (feet), (≤ 10 fathoms)
-1.372m (fathoms), (> 10 fathoms)

- IV. CONTOURS:
 - a. Use a Depth List: W00156_NOAA_depth_curves_list.txt
 - b. Line Object: DEPCNT
 - c. Value Attribute: VALDCO

- V. FEATURES:
 - a. Total Number of Features: 0
 - b. Number of Insignificant Features: 0

- VI. CHART SURVEY SOUNDINGS (CS):
 - a. Number of ENC CS Soundings: 0
 - b. Radius
 - c. Shoal biased
 - d. Use Single-Defined Radius: m on the ground
 - i. Radius Value (m): 225
 - ii. Or use a Sounding Space Range Table (if applicable): HXXXXX_SSR.txt
 - e. Filter: Interpolated != 1
 - f. Number Survey CS Soundings: 170

- VII. Notes:

[Type text]

**ATLANTIC HYDROGRAPHIC BRANCH
EVALUATION REPORT to ACCOMPANY
SURVEY W00156 (2003)**

This Evaluation Report has been written to supplement and/or clarify the original Descriptive Report. Sections in this report refer to the corresponding sections of the Descriptive Report.

B. DATA ACQUISITION AND PROCESSING

B.1 DATA PROCESSING

The following software was used to process data at the Atlantic Hydrographic Branch:

CARIS HIPS/SIPS version 6.1 SP2 HF 7
CARIS Bathy DataBASE version 2.3 HF 1-16
CARIS S-57 Composer version 2.1 HF 4
DKART INSPECTOR, version 5.0 Build 732 SP1
CARIS HOM version 3.3 SP3 HF 8

B.2. QUALITY CONTROL

B.2.1. H-Cell

The AHB source depth grid for the survey's nautical chart update product were a series of four Uncertainty BASE surface grids (1m, 2m, 4m and 8m resolution) combined to a single grid at a resolution of 8m. The survey scale soundings were created from the combined surface using a depth radius table with minimum value of one millimeter at chart scale for the affected chart scale of 1:25,000. A TIN was created from the survey scale soundings from which an interpolated surface was generated. The chart scale soundings were selected from the filtered interpolated surface using a single defined radius of 225 meters. The chart scale selected soundings are a subset of the survey scale selected soundings. The surface model was referenced when selecting the chart scale soundings to ensure that the selected soundings portrayed the bathymetry within the common area.

Depth contours were created from two shifted interpolated TIN surfaces of 8m resolution. Contours from zero to ten fathoms were created from an interpolated TIN surface that was shifted -0.75 feet. A 100 fathom contour was created from an interpolated TIN that was shifted -0.75 fathoms. The depth contours are forwarded to MCD for reference only. The contours were utilized during chart scale sounding selection and quality assurance efforts at AHB. The depth contours are incorporated into the SS H-Cell product as per 2009 H-Cell Specifications.

The pre-compilation products or components (Stand Alone HOB files (SAHOB)) are detailed in the Compile Log attached at the end of this document. The SAHOB files included depth areas (DEPARE), depth contours (DEPCNT), sounding selections (SOUNDG), cartographic Bluenotes (\$CSYMB) and Meta objects (M_COVR, M_QUAL).

All of the components with the exception of the survey scale sounding selection and depth contours were inserted into one feature layer (including the Bluenotes, as dictated by Hydrographic Technical Directive 2008-8), and this layer was exported into S-57 format in order to create the H-Cell deliverable. Similarly, the survey scale sounding selection and depth contours were exported into S-57 format separately, and then both S-57 files were processed in CARIS HOM to convert the metric units to fathoms and feet. The final products are two S-57 files, in Lat/Lon NAD-83, one that contains the chart scale soundings, and Meta objects (W00156_CS.000), and one that contains the survey scale sounding selection and depth contours (W00156_SS.000). Finally, quality assurance checks were made utilizing CARIS S-57 Composer version 2.1 validation checks and DKART INSPECTOR version 5.0 tests.

Chart compilation was performed by Atlantic Hydrographic Branch personnel in Norfolk, Virginia. Compilation data will be forwarded to Marine Chart Division, Silver Spring, Maryland.

W00156 CARIS H-Cell final deliverables include the following products:

W00156_CS.000	1:25,000 Scale	W00156 H-Cell with Chart Scale Selected Soundings
W00156_SS.000	1:10,000 Scale	W00156 Selected Soundings (Survey Scale)

C. VERTICAL AND HORIZONTAL CONTROL

The OSD-AHB-09 Horizontal and Vertical Control Report (HVCR) was not submitted with W00156 survey.

Observed water levels were applied for tide correction as there is very little tidal variation (less than one meter) in this survey area.

D. RESULTS AND RECOMMENDATIONS

D.1 CHART COMPARISON

81063 (1st Edition, Feb./06)

Corrected through NM 03/01/2006

Corrected through LNM 03/09/2010

Scale 1:25,000

D.1.1 Hydrography

The charted hydrography originates with prior surveys and requires no further consideration. There is agreement in a comparison of present sounding depths and those of the surrounding charted area.

a. The data for this project were collected in support of NOAA's Coral Reef Conservation Program goals to map all shallow (0-30m) coral reefs and was not intended to meet NOAA object detection requirements and side scan sonar coverage was not a requirement. Therefore, due to the object detection limitations inherent in the multibeam sonar used during W00156 coupled with the less than ideal along and across track

ensonified bathy node densities obtained during this survey, it is recommended all charted point “non skin of the earth features” be retained as charted.

b. Seabed characteristic density of the raster chart was excessive. Cartographic Bluenotes were added to each seabed characteristic indicating whether to retain or delete each characteristic in order to alleviate redundancy.

c. The note regarding Rota Harbor’s controlling depths should be retained as this survey predates the note. The date of survey W00156 is September 2003 while the note on the raster chart 81063 is dated May 2007.

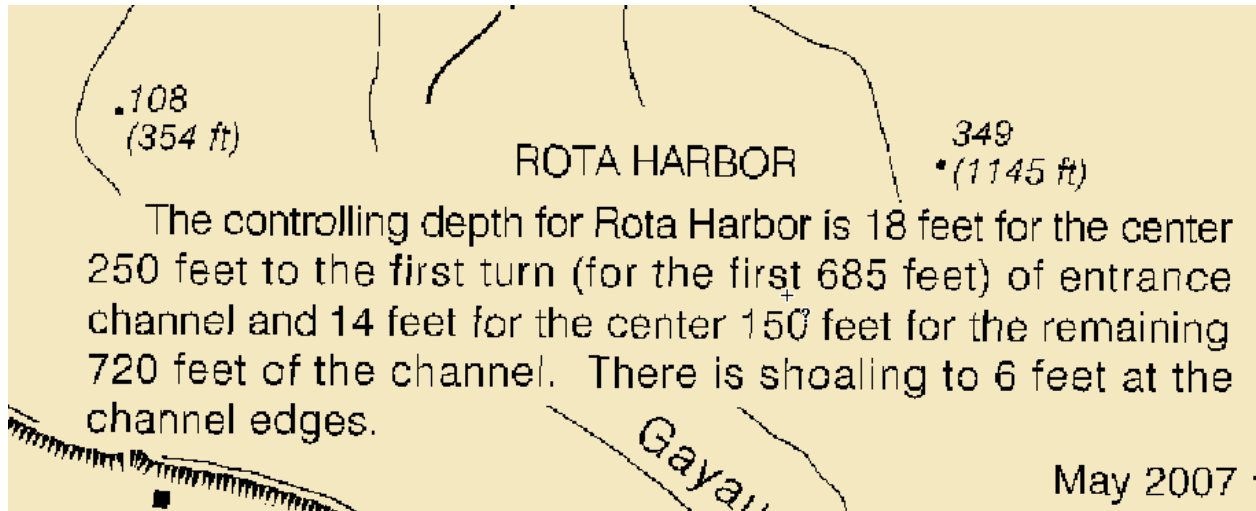

D.3. MISCELLANEOUS

Chart compilation was done by Atlantic Hydrographic Branch personnel, in Norfolk, Virginia. Compilation data will be forwarded to Marine Chart Division, Silver Spring, Maryland. See Section D.1. of this report for a list of the Raster Charts and Electronic Navigation Charts (ENC) used for compiling the present survey:

D.4. ADEQUACY OF SURVEY

The present survey is adequate to supersede the charted bathymetry within the common area. Any features not specifically addressed either in the H-Cell File or the Blue Notes should be retained as charted. Refer to the Descriptive Report for further recommendations by the hydrographer.

APPROVAL SHEET
W00156

Initial Approvals:

The completed survey has been inspected with regard to survey coverage, delineation of depth contours, disposition of critical depths, cartographic symbolization, and verification or disproval of charted data. All revisions and additions made to the H-Cell files during survey processing have been entered in the digital data for this survey. The survey records and digital data comply with National Ocean Service and Office of Coast Survey requirements except where noted in the Descriptive Report and the Evaluation Report.

All final products have undergone a comprehensive reviews per the Hydrographic surveys Division Office Processing Manual and are verified to be accurate and complete except where noted.

Kolleen McKenzie
ERT Intern
Atlantic Hydrographic Branch

I have reviewed the H-Cell files, accompanying data, and reports. This survey and accompanying Marine Chart Division deliverables meet National Ocean Service requirements and standards for products in support of nautical charting except where noted.

Approved: _____
Richard T. Brennan
Lieutenant Commander, NOAA
Chief, Atlantic Hydrographic Branch